



COMMUNITY DEVELOPMENT

333 Broadalbin Street SW, PO Box 490, Albany, Oregon 97321-0144 | BUILDING & PLANNING 541-917-7550

Staff Report

Tentative Partition Plat

RL-04-24

August 2, 2024

Summary

This proposal is a request to adjust the common property lines between three properties. The subject properties are located at 1815/1835 Elm Street SW, 930/940 18th Avenue SW, and 950/960 18th Avenue SW, Linn County Assessor's Map No. 11S-04W-12DD Tax Lots 04100, 04200, and 04300. Land Division criteria contained in Albany Development Code (ADC) 11.180 are addressed in this report for the proposed development. The criteria must be satisfied to grant approval for this application.

Application Information

Proposal:	Replat to adjust the common property lines between three properties.
Review Body:	Planning Staff (Type I-L review)
Staff Report Prepared By:	Alyssa Schrems, project planner
Property Owner 1:	Paul Kerley OBO Snow & Kerley Properties LLC; PO Box 5517, Salem, OR 97304
Property Owner 2:	Barbara West; 822 SW 10th Street, Corvallis, OR 97333
Applicant's Representative:	Caitlin Mills, MSS Inc; 215 NW 4th Street, Corvallis, OR 97330
Address/Location	1815 & 1835 Elm Street SW and 930, 940, 950, & 960 18th Avenue SW, Albany
Map/Tax Lot:	Linn County Assessor's Map No. 11S-04W-12DD Tax Lots 04100, 04200 & 04300
Zoning:	Residential Medium Density (RM)
Comprehensive Plan:	Residential- Medium Density
Overlay Districts:	None
Total Land Area:	18,250 square feet
Existing Land Use:	Duplexes and a pre-existing detached ADU
Neighborhood:	West Albany
Surrounding Zoning:	North: Residential Medium Density (RM) East: Residential Medium Density (RM) and Community Commercial (CC) South: Residential Medium Density (RM) and Community Commercial (CC) West: Residential Single-Dwelling Unit (RS-6.5 and Neighborhood Commercial (NC).

albanyoregon.gov/cd



Surrounding Uses:	North: Church and Community Service Provider East: Duplexes and McDonalds South: Duplexes and Single-Dwelling Units West: Memorial Middle School, West Albany High School, Restaurant
Prior History:	None

Staff Decision

The subject application referenced above is APPROVED as described in this staff report. The approval expires three years from the date of tentative plat approval. The final plat must be recorded with the Linn County Records Division (ADC 11.065) unless an extension is approved by the City and the county surveyor's office.

Appeals

The City's decision may be appealed to the Albany Planning Commission if a person with standing files a completed notice of intent to appeal and the associated filing fee no later than 10 days from the date the City mails the notice of decision [ADC 1.220(7)].

Notice Information

A notice of filing was mailed to property owners identified within 100 feet of the subject properties on July 15, 2024, in accordance with ADC 1.220. At the time the comment period ended on July 29, 2024, the Albany Planning Division had received no comments.

Analysis of Development Code Criteria

The ADC includes the following review criteria for a tentative plat (ADC 11.180), which must be met for these applications to be approved. Code criteria are written in **bold** followed by findings, conclusions, and conditions of approval where conditions are necessary to meet the review criteria.

Tentative Plat Review Criteria

Criterion 1

The proposal meets the development standards of the underlying zoning district, and applicable lot and block standards of this section.

Findings of Fact

- 1.1 The subject properties include portions of Lots 3-6 of the Schultz Front Addition. The subject properties are identified on Linn County Assessor Map No. 11S-04W-12DD Tax Lots 04100, 04200, and 04300 (Attachment A). The sites have been assigned addresses of 1815/1835 Elm Street SW, 930/940 18th Avenue SW, and 950/960 18th Avenue SW.
- 1.2 The underlying zoning district of the subject property is Residential Medium Density (RM). The RM district is intended primarily for medium-density residential urban development.
- 1.3 Lot size in the RM zone depends on the proposed use and ranges in size from 1,500 square feet (townhomes), 3,500 square feet (single-dwelling unit detached and duplex), to 7,000 square feet (cottage clusters and fourplexes). Parcel 3 (1815/1835 Elm) is proposed to be 5,595 square feet after the adjustment. Parcel 2 (950/960 18th) is proposed to be 5,442 square feet after the adjustment and Parcel 1 (930/940 18th) is proposed to be 7,137 square feet after the adjustment.
- 1.4 According to ADC Table 3.190-1, the minimum setback standards in the RM zoning district are as follows: 15-foot front (building), 20-foot front (vehicle entrance), three-foot side (one story), five-foot side, (two plus stories), or no setback for zero lot line dwellings. Maximum height is 45 feet and maximum lot coverage is 70 percent. The proposed adjustment would move the dividing line between Parcels 1 and 2 to be 3.1 feet from each exterior wall. At the property line the duplexes are one story, stepping up to a second story approximately 20 feet from the dividing property line. This will result in setbacks that are more conforming than they currently are. 1815/1835 Elm Street currently does not meet front setbacks but was constructed in 1950 before standards were enacted. The detached ADU

- is proposed to be adjusted from Parcel 2 to Parcel 3, with all affected property lines meeting the required setbacks.
- 1.5 In any single-dwelling unit land division, lots and blocks shall conform to standards listed in ADC 11.090 and other applicable provisions of the Code. Standards relevant to this proposed partition are addressed below.
 - 1.6 ADC 11.090(1) states lots must be arranged such that there will be no foreseeable difficulties, for reasons of topography or other conditions, in securing building permits to build on all proposed lots in compliance with the requirements of the Code. There are no foreseeable difficulties in securing building permits to build on the proposed parcels, provided applicable development standards are followed.
 - 1.7 According to ADC 11.090(2), when lots are more than double the minimum area designated by the zoning district, those lots must be arranged to allow further subdivision and the opening of future streets where it would be necessary to serve potential lots. An urban conversion plan may be required in conjunction with submittal of tentative subdivision or partition plat. No urban conversion plan is required with this application as there would be no ability to further subdivide in a way that would require future streets.
 - 1.8 ADC 11.090(3) states double frontage lots shall be avoided except when necessary to provide separation of residential developments from streets of collector or arterial street status or to overcome specific disadvantages of topography and/or orientation. Parcels 1 and 2 only have frontage on 18th Avenue SW, while Parcel 3 is a corner lot with frontage on Elm and 18th Avenue SW. Corner lots do not meet the definition of a double frontage lot, therefore this standard does not apply.
 - 1.9 ADC 11.090(4) states side yards of lots shall run at right angles to the street the property faces. The proposed property line will result in side-yards that will run at right angles to the street frontage. This standard is met.
 - 1.10 ADC 11.090(5) lists dimensional requirements when street blocks are created as part of the land division. The proposed replat does not create any new streets or blocks. This standard is not applicable.
 - 1.11 ADC 11.090(6) states off-street pedestrian pathways shall be connected to the street network and used to provide pedestrian and bicycle access in situations where a public street connection is not feasible. The existing properties both have connections to the public street and will continue to do so after the adjustment. This standard is met.
 - 1.12 ADC 11.090(7) provides recommendations for the minimum distance between arterial street intersections. No new streets or intersections are proposed; therefore, this standard is not applicable.
 - 1.13 ADC 11.090(8) regards developments located on a cul-de-sac lot. The proposed lots do not utilize a cul-de-sac; therefore, this standard is not applicable.
 - 1.14 ADC 11.090(9) pertains to flag lots. No flag lot is proposed; therefore, this standard is not applicable.
 - 1.15 ADC 11.090(10) regards street intersections and minimum curb radius. No street intersections are created or impacted by the proposed replat; therefore, this standard is not applicable.

Conclusions

- 1.1 The proposal meets the standards of the underlying zoning district or brings the lots more into conformance with regulations.
- 1.2 The proposed replat does not propose to create new blocks, intersections, or cul-de-sacs.
- 1.3 The proposed replat does not propose any double frontage lots.
- 1.4 The proposal meets the underlying development and lot and block standards of the RM zoning district.
- 1.5 This criterion is satisfied without conditions.

Criterion 2

Development of any remainder of property under the same ownership can be accomplished in accordance with this Code.

Findings of Fact

- 2.1 The proposed replat adjusts the common property lines between three developed properties. There is no remainder property under the same ownership.

Conclusion

- 2.1 The above criterion is satisfied, as there is no remainder property to consider.

Criterion 3

Adjoining land can be developed, or is provided access that will allow its development, in accordance with this Code.

Findings of Fact

- 3.1 This review criterion has been interpreted by the city council to require only that adjoining land either have access, or be provided access, to public streets.
- 3.2 ADC 12.060 requires that development must have frontage on, or approved access to, a public street currently open to traffic.
- 3.3 ADC 12.110 states new streets may be required to be located where the City Engineer determines additional access is needed to relieve, or avoid, access deficiencies on adjacent or nearby properties.
- 3.4 The subject properties and all adjoining lots have access to public streets. No new streets are proposed by this application.

Conclusions

- 3.1 All the adjoining land has, and will continue to have, access to public streets.
- 3.2 This criterion is met without conditions.

Criterion 4

The proposed street plan affords the best economic, safe, and efficient circulation of traffic possible under the circumstances.

Findings of Fact

- 4.1 ADC 12.060 requires public streets adjoining new development be improved to City standards. No new development is proposed as part of this replat.
- 4.2 No new or interior streets are proposed with the replat.

Conclusions

- 4.1 No new development or new interior streets are proposed with the replat.
- 4.2 This criterion is satisfied without conditions.

Criterion 5

The location and design allow development to be conveniently served by various public utilities.

Findings of Fact

Sanitary Sewer

- 5.1 City utility maps show an eight-inch public sanitary sewer main along the southern boundary of the subject properties. City documents indicate the existing buildings are currently connected to the public sewer system.

- 5.2 The proposed property replat will not negatively affect public sanitary sewer services to the existing home, or impact sewer service availability for future developments on these parcels.

Water

- 5.3 City utility maps show an eight-inch public water main in 18th Avenue and a 24-inch public water main in Elm Street. The existing buildings are currently connected to the public water system in 18th Avenue.
- 5.4 The proposed property replat will not negatively affect public water services to the existing home, or impact water service availability for future development on these parcels.

Storm Drainage

- 5.5 City utility maps show a 24-inch public storm drainage main in Elm Street. Eighteenth Avenue and Elm Street are improved to City standards with curb and gutter.
- 5.6 The proposed property replat will not negatively affect public storm drainage services to the existing home or impact storm drainage service availability for future development on these parcels.

Conclusions

- 5.1 The proposed replat will have no adverse impact on public utility services to the subject properties.
- 5.2 This criterion is satisfied without conditions.

Criterion 6

Activities and developments within special purpose districts must comply with the regulations described in Articles 4 (Airport Approach), 6 (Natural Resources), and 7 (Historic), as applicable.

Findings of Fact

- 6.1 Article 4: Airport Approach District: Figure 4.410-1 of the ADC shows the subject property is not located within the Airport Approach District.
- 6.2 Article 6 Floodplain Overlay District: Comprehensive Plan Plate 5: Based on the Federal Emergency Management Agency (FEMA) Flood Insurance Rate Map (FIRM# 41043C0256G, dated September 29, 2010) the subject property is located outside of the Special Flood Hazard Area (SFHA), otherwise known as the 100-year floodplain.
- 6.3 Article 6 Hillside Development Overlay District: According to Chapter 11, Plate 7 of the Comprehensive Plan, the subject property is not located in the Hillside Development District.
- 6.4 Article 6 Riparian Corridor Overlay District: The subject property is not located within a Riparian Corridor Overlay District.
- 6.5 Article 6 Significant Wetlands Overlay District: The subject property is not located within a Significant Wetlands Overlay District.
- 6.6 Article 6 Habitat Assessment Overlay District: The subject property is not located within the Habitat Assessment Overlay District.
- 6.7 Historic and Archaeological Resources: According to Chapter 11, Plate 9 of the Comprehensive Plan, the properties are not located in a historic district, nor are there any known archaeological resources on site.

Conclusions

- 6.1 No development is proposed that would impact special purpose overlay districts.
- 6.2 This criterion is met without conditions.

Overall Conclusion

As proposed, the application for tentative replat to adjust the common property lines between three parcels meets all applicable review criteria as outlined in this report.

Attachments

- A. Location Map
- B. Proposed Tentative Replat

Acronyms

ADC	Albany Development Code
AMC	Albany Municipal Code
CC	Community Commercial Zoning
FEMA	Federal Emergency Management Agency
FIRM	Flood Insurance Rate Map
NC	Neighborhood Commercial Zoning District
NWI	National Wetland Inventory
ORD	Ordinance
RL	Replat File Designation
RM	Residential Medium Density Zoning District
RS-6.5	Residential Single-Dwelling Unit District
SFHA	Special Flood Hazard Area

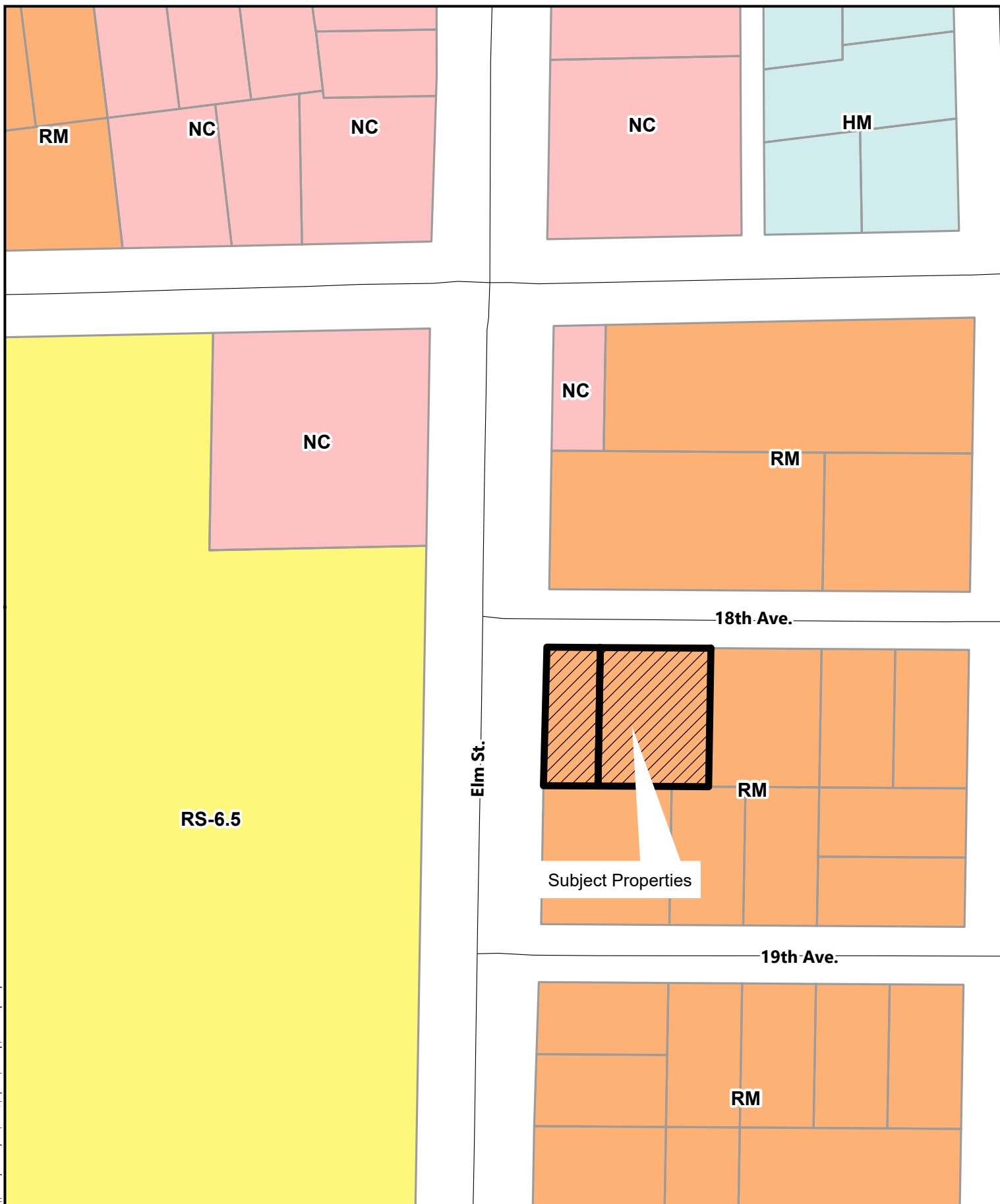

\\con.cityofalbany.net\homas\analysis\ss\ Desktop\Notice Map Template.mxd

Elm St.

18th Ave.

19th Ave.

RS-6.5

NC

HM

RM

NC

NC

NC

NC

RM

RM

RM

Subject Properties

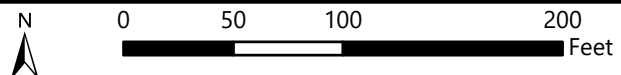

1815 Elm, 950 18th Ave SW

Date: 6/18/2024 Map Source: City of Albany

Location Map

GENERAL NOTES:

- THE SUBJECT PROPERTIES ARE LOCATED AT 1815 & 1835 SW ELM ST, 930, 940, 950, & 960 18TH AVE SW, IN THE SE 1/4 OF SECTION 12, TOWNSHIP 11S, RANGE 4W, W.M. THE LEGAL DESCRIPTION IS LOTS 3, 4, 5, 6, BLOCK 2, SCHULTZ FRONT ADDITION TO ALBANY
- ZONING & COMP. PLAN DESIGNATION: RM - RESIDENTIAL MULTIFAMILY
- SUBJECT & ADJACENT USES:
 - SINGLE DWELLING UNIT, DETACHED
 - DUPLEX
 - MULTIPLE DWELLING UNITS
 - PRIMARY RESIDENCE WITH ONE ADU
 - EDUCATIONAL INSTITUTION
- DENSITY REQUIREMENTS: 3500 SF MINIMUM FOR SINGLE FAMILY AND DUPLEX.
- OWNERS: TL4100 - BARBARA WEST, TL4200 & TL4300 - SNOW & KERLEY PROPERTIES LLC.
- SURVEYOR : MSS INC.
- TOTAL AREA: 18173 SQUARE FEET / 0.42 ACRES
- ALL EXISTING FEATURES TO BE RETAINED, NO PROPOSED DEVELOPMENT

LEGEND

	PROPERTY BOUNDARY		STORM MANHOLE
	ADJACENT PROPERTY LINES		STORM CURB INLET
	CENTERLINE		SEWER MANHOLE
	RIGHT OF WAY		WATER METER
	EASEMENT LINES		WATER VALVE
	BUILDING		POWER/UTILITY POLE
	CURB		GAS METER
	SIDEWALK		
	FENCE		
	WATERLINE		
	SANITARY SEWER		
	STORM DRAIN LINE		
	OVERHEAD POWER		
	COMMUNICATION LINE		

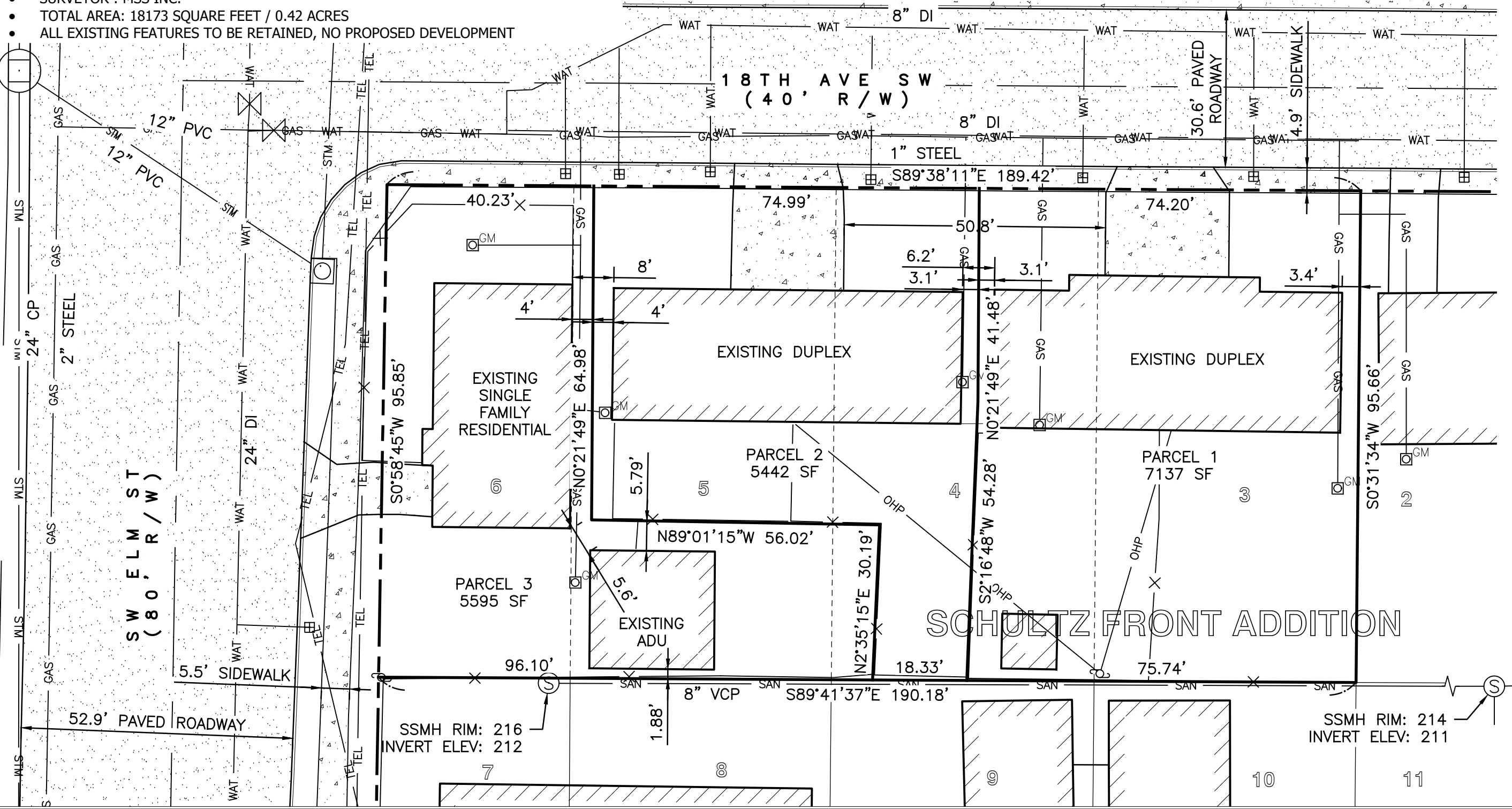
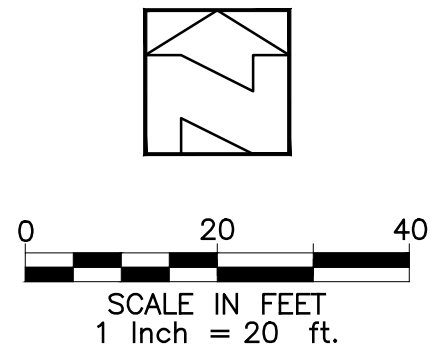

PAUL KERLEY
131 PINE STREET NE
SALEM, OREGON
(503) 349-1616

**SW ELM ST / 18TH AVE SW REPLAT
ALBANY, OREGON
TENTATIVE PLAT**

MSS INC
ENGINEERING CONSULTANTS
AND PLANNERS
215 NW 4th STREET
CORVALLIS, OR 97330
(541) 753-1320 FAX: (541) 753-5966

JOB # 23133 FILE TENT PLAT DBS
SCALE 1" = 20' DATE 3/14/2024
P100
1 OF 1 SHEETS

TAXMAP: 11S04W12DD - TAXLOTS 4100, 4200 & 4300