



## COMMUNITY DEVELOPMENT

333 Broadalbin Street SW, PO Box 490, Albany, Oregon 97321-0144 | Community Development 541-917-7550

# Notice of Decision

## Site Plan Review

SP-11-23

June 22, 2023

### Application Information

Proposal:	To construct a new 900 square-foot residential accessory building
Review Body:	Staff (Type I-L review)
Report Prepared By:	Jennifer Cepello, Planner III
Property Owner/Applicant:	John Origer; 3511 Bernard Avenue NE, Albany, OR 97322
Address/Location:	3511 Bernard Avenue NE, Albany, OR 97322
Map/Tax Lot:	Linn County Tax Assessor's Map No. 10S-03W-33DB; Tax Lot 601
Zoning:	Residential Single-Family (RS-6.5)

On June 22, 2023, the City of Albany Community Development Director granted **Approval** of the application referenced above.

The City based its decision on the project's conformance with the review criteria listed in the Albany Development Code (ADC). The supporting documentation relied upon by the City in making this decision is available for review at City Hall, 333 Broadalbin Street SW. For more information, please contact **Jennifer Cepello**, project planner, at 541-917-7561 or Current Planning Manager David Martineau at 541-917-7555.

The City's decision may be appealed to the Albany Planning Commission if a person with standing files a completed notice of intent to appeal and the associated filing fee no later than 10 days from the date the City mails the notice of decision [ADC 1.220(7)]. The applicants may proceed, at their own risk, prior to the end of the appeal period, provided they sign a Release and Indemnity Agreement with the City.

This approval shall expire three years from the date of approval unless 1) the applicant has installed all of the required public infrastructure related to the development and the infrastructure has been accepted by the City, or 2) the applicant has provided financial assurance for all required public infrastructure per ADC Section 12.600, or 3) the development did not require public infrastructure, a valid building permit exists for new construction or improvements, and work has commenced.

*Signature on file*

Community Development Director

**Appeal Deadline: July 3, 2023**

**Approval Expiration Date (if not appealed): June 22, 2026**

Attachments: Location Map, Site Plan, Elevations

[cd.cityofalbany.net](http://cd.cityofalbany.net)



## Conditions of Approval

- Condition 1 The applicant must include a detailed storm drainage plan with building permit submittal. The drainage plan shall show how the roof drainage from the proposed structure will be discharged to a point approved by the Engineering Department.
- Condition 2 Development shall occur consistent with the plans and narrative submitted by the applicant, or as modified by conditions of approval and shall comply with all applicable state, federal, and local laws.

## Information for the Applicant

Please read the following requirements. This list is not meant to be all-inclusive; we have tried to compile requirements that relate to your specific type of development. These requirements are not conditions of the land use decision. They are Albany Municipal Code (AMC) or ADC regulations or administrative policies of the planning, engineering, fire, or building departments that you must meet as part of the development process. You must comply with state, federal, and local law. The issuance of this permit by the City of Albany does not eliminate the need for compliance with other federal, state, or local regulations. It is the applicant's responsibility to contact other federal, state, or local agencies or departments to assure compliance with all applicable regulations.

### Planning

1. Land use approval does not constitute building or public works permit approvals.
2. Construction of the development must substantially conform to the approved Site Plan Review.

### Building

The Building Division within Community Development have provided the following comments:

1. The proposed project may require permits that will need to be applied for at [www.cityofalbany.net/permits](http://www.cityofalbany.net/permits). For questions about permitting requirements, please email [cd.customerservice@cityofalbany.net](mailto:cd.customerservice@cityofalbany.net).
2. The proposed design has not been reviewed for code compliance with the Oregon Building Code and the design will need to meet the applicable Oregon Building Code requirement in effect at time of application.

### Public Works - Engineering

The City of Albany's infrastructure records, drawings, and other documents have been gathered over many decades, using differing standards for quality control, documentation, and verification. All information provided represents the current information we have in a readily available format. While the information we provide is generally believed to be accurate, occasionally this information proves to be incorrect, and thus we do not warrant its accuracy. Prior to making any property purchases or other investments based, in full or in part, upon the information provided, we specifically advise that you independently field verify the information contained within our records.

An erosion prevention and sediment control (EPSC) permit shall be obtained for land-disturbing activities affecting an area of 2,000 square feet or greater, cumulatively (AMC 12.40.030).

### Fire

The fire department has reviewed the above project for conformance to the 2019 Oregon Fire Code and has no comments.



G:\Community Development\Planning Land Use Cases\2023\Site Plan Review (SP)\SP-11-23\3511 Bernard Ave NE\Public Notice Location Map.mxd

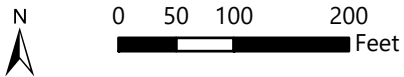

**3511 Bernard Ave NE**

Date: 4/21/2023 Map Source: City of Albany

Location Map

North

3511 Bernard Ave  
Albany, OR  
97322

West

E

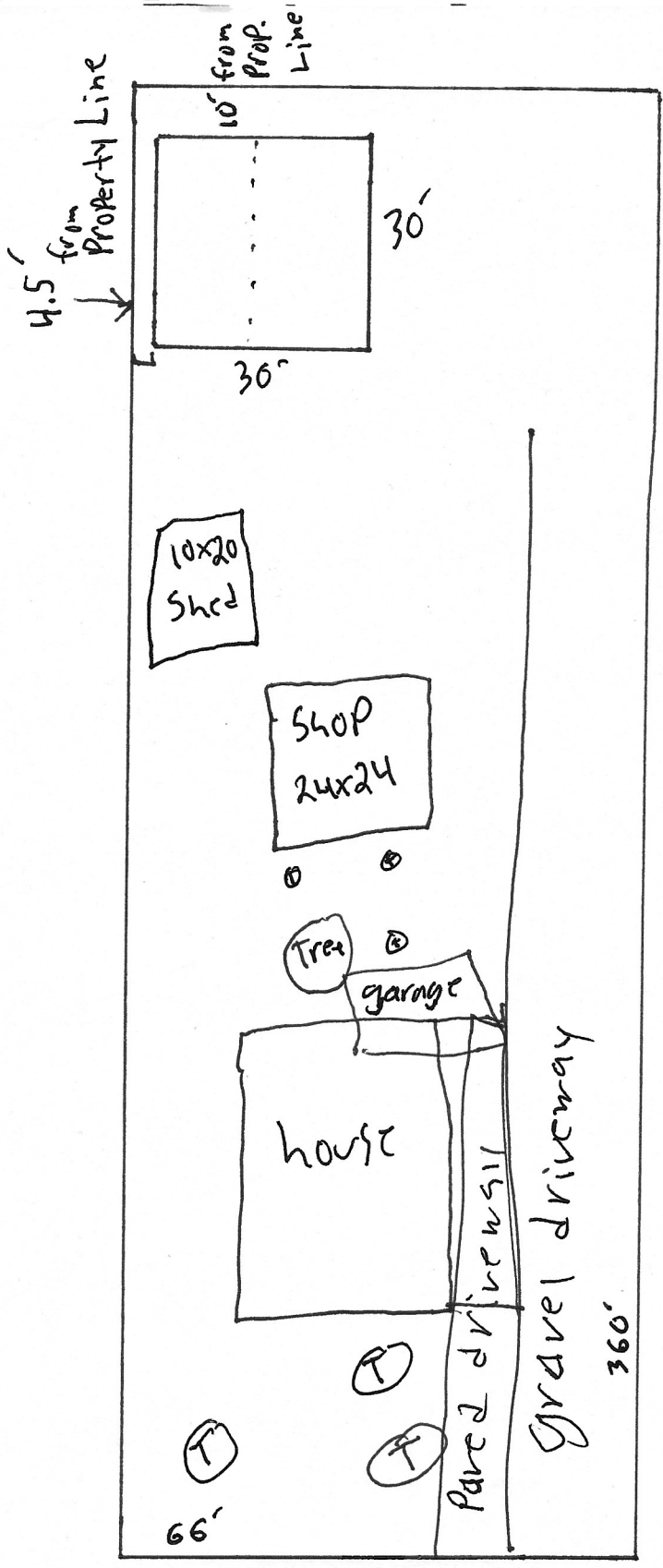

Bernard Ave

S



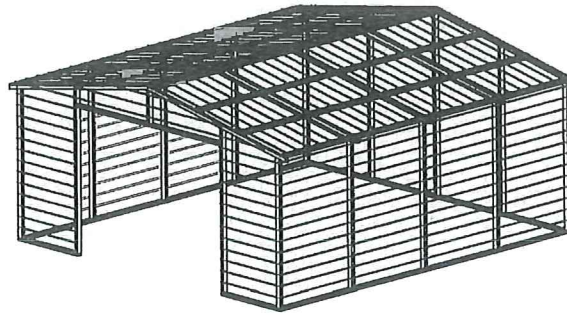
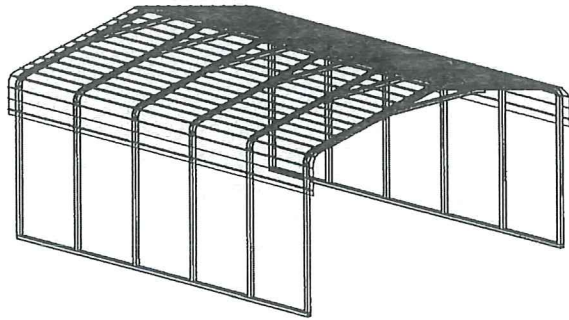

## REGULAR / A-FRAME 30'-0" WIDE CARPORT STYLE BUILDINGS

### DESIGN NOTES

1. ALL CONSTRUCTION SHALL BE PROVIDED IN ACCORDANCE WITH IBC 2018, OSHA, AISC 360, AISI 100, ASCE 7-16, AWS D1.3 CODES AND ALL APPLICABLE LOCAL REQUIREMENTS.
2. ALL MATERIALS IDENTIFIED BY MANUFACTURER NAME MAY BE SUBSTITUTED WITH MATERIAL EQUAL OR EXCEEDING ORIGINAL.
3. ALL SHOP CONNECTIONS SHALL BE WELDED CONNECTIONS.
4. ALL STRUCTURAL FIELD CONNECTIONS SHALL BE #12-14 X 3/4" SDS (ESR-2196 OR EQ) WITHOUT WASHERS.
5. STEEL SHEATHING SHALL BE 29GA. CORRUGATED GALV. OR PAINTED STEEL - MAIN RIB HT. 3/4" (FY=80KSI) OR EQ. CONNECTIONS SHALL BE #12-14 X 3/4" SDS (ESR-2196 OR EQ) WITH NEOPRENE WASHERS.
6. ALL STRUCTURAL LIGHT GAUGE TUBING AND CHANNELS SHALL BE GRADE 50 STEEL (FY = 50 KSI, FU = 65 KSI).
7. STRUCTURAL TUBE 2 1/2" X 2 1/2" - 14GA. IS EQUIVALENT TO TS 2 1/4" X 2 1/4" - 12GA AND EITHER ONE MAY BE USED IN LIEU OF THE OTHER.
8. GYPSUM BOARD OR DRYWALL FINISH OR ANY BRITTLE BASE MATERIAL IS NOT CONSIDERED OR ACCOUNTED FOR ON THE DESIGN CRITERIA.
9. ALL DESIGN CRITERIA MUST BE INCREASED TO THE NEXT HIGHER INCREMENT BASED ON THE TABLES ON PAGE 4. NO INTERPOLATION IS ALLOWED.

### DESIGN CRITERIA

PREVAILING CODE:	OSSC 2019 (IBC 2018)
USE GROUP:	U (CARPORTS, BARNS)
RISK CATEGORY:	1
1. DEAD LOAD (D)	D = 4 PSF
2. ROOF LIVE/SNOW LOAD (Lr)	Lr = 20 - 61 PSF (AS PER SNOW LOAD SEE TABLE 4)
3. SNOW LOAD (S)	
GROUND SNOW LOAD	P <sub>g</sub> = 20 - 90 PSF
IMPORTANCE FACTOR	I <sub>s</sub> = 0.8
THERMAL FACTOR	C <sub>t</sub> = 1.2
EXPOSURE FACTOR	C <sub>e</sub> = 1.0
ROOF SLOPE FACTOR	C <sub>s</sub> = 1.0
4. WIND LOAD (W)	
BASIC WIND SPEED	V <sub>ULT</sub> = 105 - 180 MPH
EXPOSURE	C
5. SEISMIC LOAD (E)	
DESIGN CATEGORY	D
IMPORTANCE FACTOR	I <sub>e</sub> = 1.00
<u>LOAD COMBINATIONS:</u>	
1.	D + (Lr OR S)
2.	D + (0.6W OR ±0.7E)
3.	D + 0.75 (0.6W OR ±0.7E) + 0.75 (Lr OR S)
4.	0.6D + (0.6W OR ±0.7E)

### DRAWING INDEX

COVER SHEET	----	1
SCHEDULES & MEMBER - SECTIONS	----	2
FRAME SECTIONS & DETAILS	----	3
SPACING SCHEDULES - & ENCLOSURE NOTES	----	4
PURLIN & GIRT SCHEDULES	----	5
SHEATHING OPTIONS	----	6
SIDE WALL FRAMING & OPENINGS	----	7-A, 7-B
END WALL FRAMING & OPENINGS	----	8-A, 8-B
CORNER BRACING DETAILS	----	9
OPTIONAL LEAN-TO ADDITION	----	10
FOUNDATION OPTIONS	----	11-A TO 11-D

MANUFACTURED BY:



457 N. Broadway,  
Joshua, TX 76058  
1-866-730-9865

ENGINEERED BY:



**A&A ENGINEERING**  
CIVIL • STRUCTURAL  
6063 Renaissance Place, Toledo, OH 43623  
Tel. 419-292-1983 • Fax. 419-292-0955  
www.aa-engineers.com

### DRAWING INFORMATION

PROJECT: 30'-0" WIDE BUILDINGS  
LOCATION: STATE OF OREGON  
PROJECT NO.: 233-23-0070  
SHEET TITLE:

### COVER SHEET

SHEET NO.: 1 / 11  
DRAWN BY: A.W. DATE: 1/25/22  
CHECKED BY: OAA DATE: 1/25/22

### LEGAL INFORMATION

- ANY DUPLICATION OF THIS DRAWING IN WHOLE OR PART IS STRICTLY FORBIDDEN. ANYONE DOING SO WILL BE PROSECUTED UNDER THE FULL EXTENT OF THE LAW.  
- DRAWINGS VALID UP TO 1 YEAR FROM DATE OF ISSUE.

SEAL:



### CUSTOMER INFORMATION

OWNER:  
ADDRESS:

### DESIGN LOADS

GROUND SNOW:  
ROOF LIVE LOAD:  
BASIC WIND SPEED:

### BUILDING INFORMATION

WIDTH:  
LENGTH:  
HEIGHT:

### CERTIFICATION VALIDITY NOTICE

FRAME TYPE:  A-FRAME  
 REGULAR  
ENCLOSURE TYPE:  FULL  
 PARTIAL  
 OPEN

DATE OF PLANS EXPIRATION: **01-13-2024**

CERTIFICATION ON THESE DRAWINGS IS VALID FOR ONE YEAR FROM DATE OF ISSUE

STAMP EXPIRY: **12-31-2023**  
DATE SIGNED: **01-13-2023**

TABLE 2.1: MEMBER PROPERTIES

NO.	LABEL	PROPERTY	DETAIL NO.
1	COLUMN POST	2.5" X 2.5" X 14GA TUBE W/ 2.25" X 2.25" X 12GA TUBE INSERT	11
2	ROOF BEAM	2.5" X 2.5" X 14GA TUBE	1
3	BASE RAIL	2.5" X 2.5" X 14GA TUBE	1
4	PEAK BRACE	2.5" X 2.5" X 14GA TUBE	1
5	KNEE BRACES	2.5" X 1.5" 14GA CHANNEL	4
6	CONNECTOR SLEEVE	2.25" X 2.25" X 12GA TUBE	2
7	BASE ANGLE	2" X 2" X 3" LG. 3/16" ANGLE	10
8	PURLIN	4.25" X 1.5" X 18GA / 14GA HAT CHANNEL	5
9	GIRT	4.25" X 1.5" X 18GA / 14GA HAT CHANNEL	5
10	SHEATHING	29 GA CORRUGATED SHEET	8
11	END WALL POST	2.5" X 2.5" X 14GA TUBE	1
12	DOOR POST	2.5" X 2.5" X 14GA TUBE	1
13	SINGLE HEADER	2.5" X 2.5" X 14GA TUBE	1
14	DOUBLE HEADER	DBL. 2.5" X 2.5" X 14GA TUBE	1
15	SERVICE DOOR / WINDOW FRAMING	2.5" X 2.5" X 14GA TUBE	1
16	ANGLE BRACKET	2" X 2" X 2" LG. 14GA ANGLE	7
17	STRAIGHT BRACKET	2" X 2" X 4" LG. 14GA PLATE	6
18	PB SUPPORT	2.5" X 2.5" X 14GA TUBE	1
19	DIAGONAL BRACE	2" X 2" X 14 GA TUBE	3
20	GABLE BRACE	2" X 2" X 14 GA TUBE	3
21	DB BRACKET	2.25" X 2.25" X 6" X 14GA ANGLE	9
22	TRUSS SPACER	2.5" X 2.5" X 14GA TUBE	1
23	ALL FASTENERS	#12 X 1" SELF-DRILL SCREWS (ESR-2196 OR EQ) W/ NEOPRENE/STEEL WASHER	

TABLE 2.2: SHEATHING FASTENER SCHEDULE

LOCATION	CORNER PANELS	SIDE LAPS	EDGE LAPS	ELSEWHERE
SPACING	9" C/C	MIN. 1	4 1/2" C/C	9" C/C

FASTENER TYPE: #12X1" SELF-DRILL SCREWS (ESR-2196 OR EQ) W/ NEOPRENE/STEEL WASHER  
 \*SEE TYP. SHEATHING FASTENER SCHEDULE DIAGRAM ON PAGE 6.

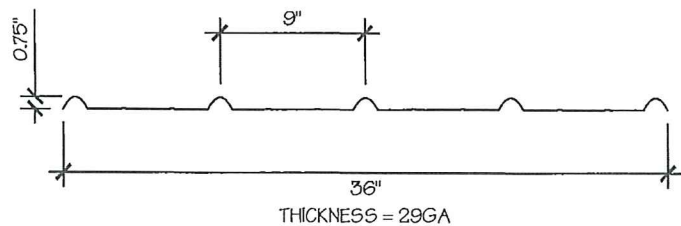

29 GA CORRUGATED SHEATHING (8)  
 SCALE: NTS

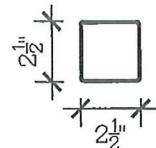

2.5" X 2.5" 14GA TUBE (1)  
 SCALE: NTS

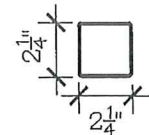

2.25" X 2.25" 12GA TUBE (2)  
 SCALE: NTS

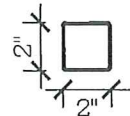

2" X 2" 14GA TUBE (3)  
 SCALE: NTS

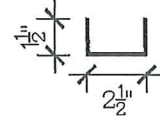

2.5" X 1.5" 14GA CHANNEL (4)  
 SCALE: NTS

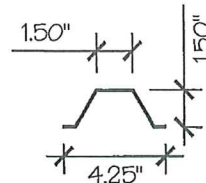

4.25" X 1.5" X 18GA / 14GA HAT CHANNEL (5)  
 SCALE: NTS

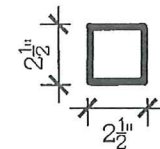

2.5" X 2.5" X 14GA TUBE W/ 2.25" X 2.25" X 12GA TUBE INSERT (11)  
 SCALE: NTS  
 NOTE: INSERT FULL LENGTH & FIELD BOLT W/ [23] FASTENERS @ 12" C/C STAGGERED OPPOSITE FACE

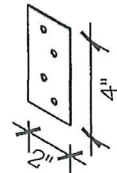

STRAIGHT BRACKET (6)  
 THICKNESS = 14GA  
 SCALE: NTS

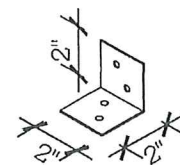

ANGLE BRACKET (7)  
 THICKNESS = 14GA  
 SCALE: NTS

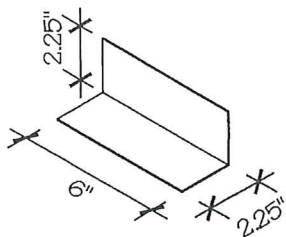

DB BRACKET (9)  
 THICKNESS = 14GA  
 SCALE: NTS

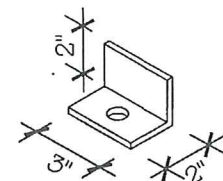

BASE ANGLE (10)  
 THICKNESS = 3/16"  
 SCALE: NTS

MANUFACTURED BY:



457 N. Broadway,  
 Joshua, TX 76058  
 1-866-730-9865

ENGINEERED BY:



A&A ENGINEERING  
 CIVIL • STRUCTURAL  
 6063 Renaissance Place, Toledo, OH 43623  
 Tel. 419-292-1983 • Fax. 419-292-0955  
 www.aa-engineers.com

DRAWING INFORMATION

PROJECT: 30'-0" WIDE BUILDINGS  
 LOCATION: STATE OF OREGON  
 PROJECT NO.: 233-23-0070  
 SHEET TITLE:

SCHEDULES & MEMBER SECTIONS

SHEET NO.: 2 / 11  
 DRAWN BY: A.W. DATE: 1/25/22  
 CHECKED BY: OAA DATE: 1/25/22

LEGAL INFORMATION

- ANY DUPLICATION OF THIS DRAWING IN WHOLE OR PART IS STRICTLY FORBIDDEN. ANYONE DOING SO WILL BE PROSECUTED UNDER THE FULL EXTENT OF THE LAW. - DRAWINGS VALID UP TO 1 YEAR FROM DATE OF ISSUUE.

SEAL:



STAMP EXPIRY: 12-31-2023  
 DATE SIGNED: 01-13-2023



MANUFACTURED BY:



457 N. Broadway,  
Joshua, TX 76058  
1-866-730-9865

ENGINEERED BY:



**A&A ENGINEERING**  
CIVIL • STRUCTURAL  
6063 Renaissance Place, Toledo, OH 43623  
Tel. 419-292-1983 • Fax. 419-292-0955  
www.aa-engineers.com

**DRAWING INFORMATION**

PROJECT: 30'-0" WIDE BUILDINGS

LOCATION: STATE OF OREGON

PROJECT NO.: 233-23-0070

SHEET TITLE:

**FRAME SECTIONS & DETAILS**

SHEET NO.: 3 / 11

DRAWN BY: A.W. DATE: 1/25/22

CHECKED BY: OAA DATE: 1/25/22

**LEGAL INFORMATION**

- ANY DUPLICATION OF THIS DRAWING IN WHOLE OR PART IS STRICTLY FORBIDDEN. ANYONE DOING SO WILL BE PROSECUTED UNDER THE FULL EXTENT OF THE LAW. - DRAWINGS VALID UP TO 1 YEAR FROM DATE OF ISSUE.

SEAL:



STAMP EXPIRY: 12-31-2023

DATE SIGNED: 01-13-2023

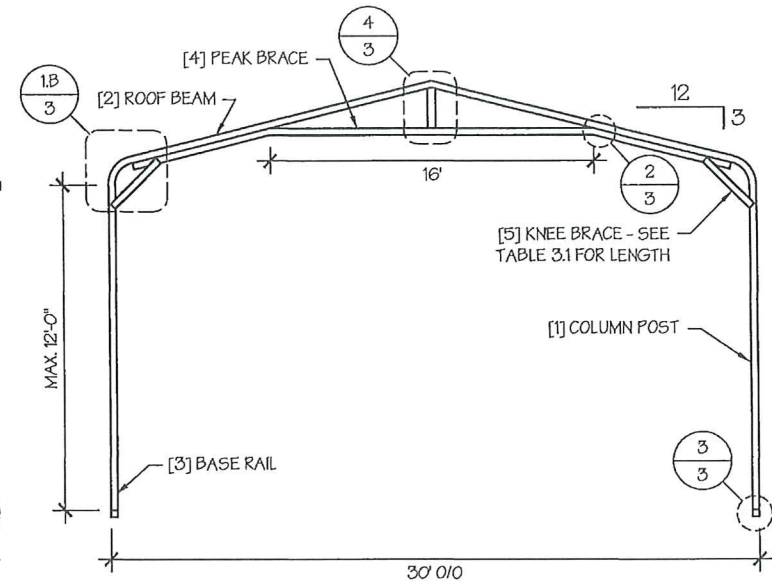
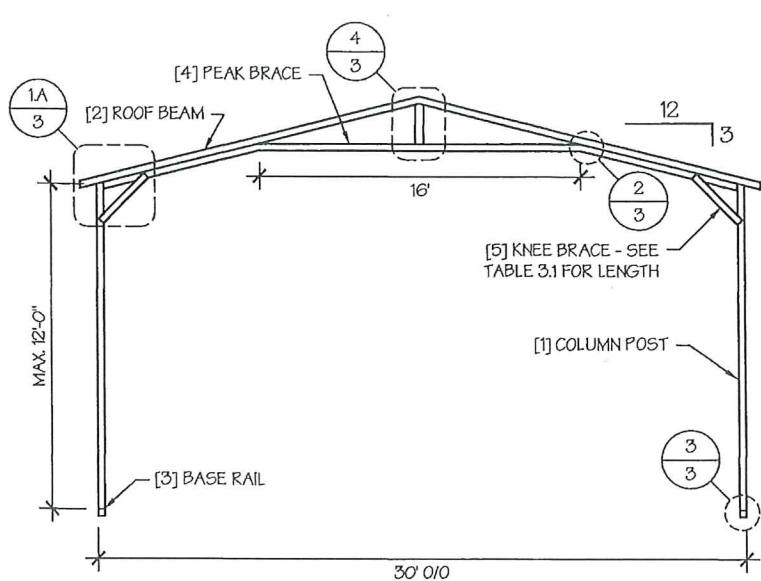

TYP. A-FRAME SECTION  
SCALE: NTS

TYP. REGULAR FRAME SECTION  
SCALE: NTS

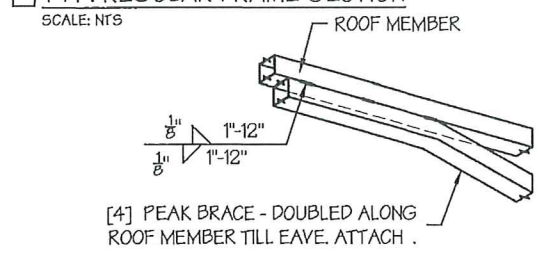
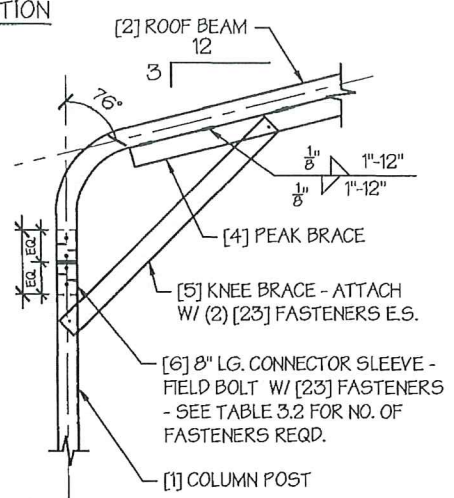
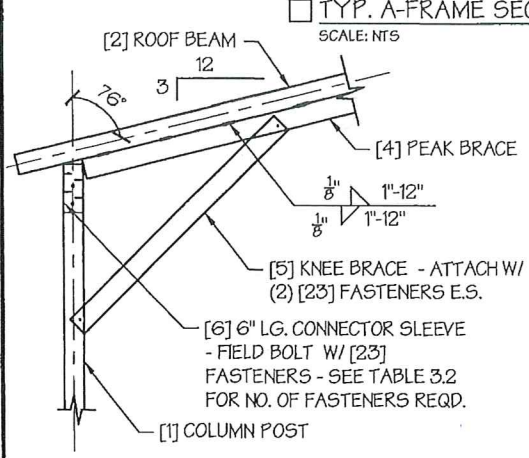

**PEAK BRACE CONNECTION DETAILS** 2  
SCALE: NTS

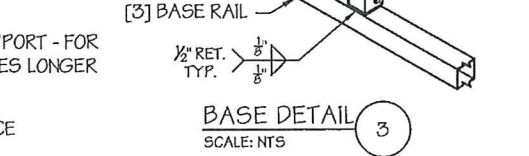
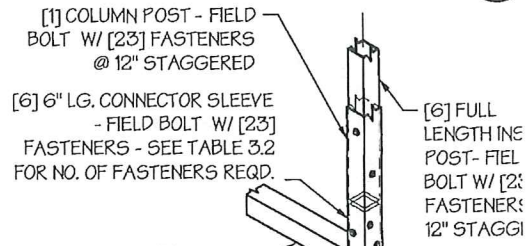

**BASE DETAIL** 3  
SCALE: NTS

A. A-FRAME

**EAVE DETAIL** 1  
SCALE: NTS

B. REGULAR FRAME

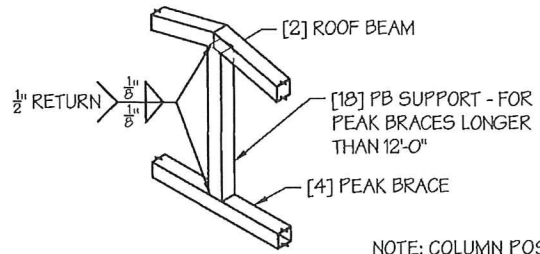

**PB SUPPORT DETAIL** 4  
SCALE: NTS

NOTE: COLUMN POST MAY BE ADJUSTED ±1" FOR LEVELING. MANUFACTURER IS NOT RESPONSIBLE FOR LEVELING OF GROUND AND/OR CONCRETE SURFACE PROVIDED BY OTHERS.

**TABLE 3.1: KNEE BRACE SCHEDULE**

EAVE HEIGHT	KNEE BRACE LENGTH
<input type="checkbox"/> UP TO 8'	24"
<input type="checkbox"/> 9' TO 12'	36"

**TABLE 3.2 FASTENER SCHEDULE**

WIND SPEED (MPH)	NO. OF FASTENERS
<input type="checkbox"/> 105 TO 125	4
<input type="checkbox"/> 130 TO 155	6
<input type="checkbox"/> 160 TO 180	8



TABLE 4: FRAME SPACING CHART / SCHEDULE

GROUND SNOW / ROOF LIVE LOAD (PSF)	■ ENCLOSED BUILDINGS							■ OPEN BUILDINGS						
	WIND SPEED (MPH)							WIND SPEED (MPH)						
	□105	□115	□130	□140	□155	□165	□180	□105	□115	□130	□140	□155	□165	□180
□ 30 / 20	60	60	54/60	54	48	42/48	36/42	54	48/54	42/48	42	36/42	36	30
□ 40 / 27	48/60	48/60	42/60	42/54	48	42/48	36/42	48	48	42/48	42	36/42	36	30
□ 50 / 34	40/48	40/48	40/48	40/48	40/48	40/48	36/42	40/42	40/42	40/42	40/42	36	36	30
□ 60 / 41	36/42	36/42	36	36	36	36	36	36	36	30	30	30	30	24
□ 70 / 47	32/36	32/36	32/36	32/36	30	30	30	30	30	30	24	24	24	24
□ 80 / 54	24	24	24	24	24	24	24	24	24	24	24	24	24	---
□ 90 / 61	18	18	18	18	---	---	---	18	18	---	---	---	---	---
□ 30 / 20	60	60	54/60	54	48	42/48	36/42	54	48/54	42/54	42/48	36/42	36/42	30/36
□ 40 / 27	48/60	48/60	42/60	48/54	48	42/48	36/42	48	48	42/48	42/48	36/42	36/42	30/36
□ 50 / 34	40/54	40/54	40/54	40/48	40/48	40/48	36/42	40/42	40/42	40/42	40/42	36/42	36	30/36
□ 60 / 41	36/48	36/42	36/42	36/42	36/42	36/42	36/42	36	36	36	36	36	36	30/36
□ 70 / 47	32/36	32/36	32/36	32/36	32/36	30	30	30	30	30	30	30	30	24
□ 80 / 54	30	30	30	30	30	30	30	24	24	24	24	24	24	24
□ 90 / 61	24	24	24	24	24	24	24	18	18	18	18	18	18	18
□ 30 / 20	60	60	54/60	54	48	42/48	36/42	54	48/54	42/54	42/54	36/48	36/48	30/36
□ 40 / 27	48/60	48/60	42/60	42/54	42/48	42/48	36/42	48	48	42/48	42/48	36/48	36/48	30/36
□ 50 / 34	40/54	40/54	40/54	40/48	40/48	40/48	36/42	40/42	40/42	40/42	40/42	36/42	36/42	30/36
□ 60 / 41	36/48	36/48	36/48	36/48	36/42	36/42	36/42	36	36	36	36	36	36	30/36
□ 70 / 47	32/42	32/42	32/36	32/36	32/36	32/36	30	32/36	32/36	30	30	30	30	24
□ 80 / 54	30/36	30/36	30/36	30/36	30/36	30	30	30	30	30	30	30	24	24
□ 90 / 61	30/36	30/36	30	30	30	30	30	24	24	24	24	---	---	---

■ EAVE HEIGHT = 10'-0" TO 12'-0"  
 ■ EAVE HEIGHT = 7'-0" TO 9'-0"  
 ■ EAVE HEIGHT = UP TO 6'-0"

- NOTES:**
- FRAME SPACINGS ARE IN UNITS OF INCHES (IN).
  - WHERE TWO VALUES ARE SHOWN, THE HIGHER VALUE CAN ONLY BE USED FOR VERTICAL SHEATHING.
  - SNOW LOADS AND ROOF LIVE LOADS ARE IN POUNDS PER SQUARE FOOT (PSF). WIND SPEED IS 3 SEC. GUST IN MILES PER HOUR (MPH).
  - FOR VALUES THAT LIE BETWEEN TWO CELLS, THE HIGHER (MORE STRINGENT) VALUE HAS TO BE USED. INTERPOLATION BETWEEN CELLS IS NOT ALLOWED.

**ENCLOSURE CLASSIFICATION:**

- ENCLOSED BUILDING** = ALL 4 WALLS FULLY ENCLOSED WITH DOORS/WINDOWS = USE ENCLOSED BUILDING SPACING CHART.
- OPEN BUILDING** = ALL 4 WALLS FULLY OPEN = USE OPEN BUILDING SPACING CHART.
- 3FT PARTIALLY ENCLOSED** = BOTH END-WALLS FULLY OPEN, WITH BOTH SIDE-WALLS ONLY 3FT ENCLOSED = USE OPEN BUILDING SPACING CHART.
- PARTIALLY ENCLOSED** = BOTH END-WALLS FULLY OPEN, WITH BOTH SIDE-WALLS ENCLOSED MORE THAN 3FT = START WITH OPEN BUILDING SPACING CHART AND THEN REDUCE SPACING BY 6".
- 3 SIDED ENCLOSED** = ALL WALLS ARE ENCLOSED EXCEPT FOR 1 END-WALL = START WITH ENCLOSED BUILDING SPACING + THE OPEN END FRAME MUST HAVE EITHER A GABLED END OR HAVE DOUBLED WELDED LEGS & ROOF.
- FOR ALL SHEATHING ENCLOSURES NOT LISTED ABOVE, REFER TO SHEET 5 FOR SPACING AND DESIGN REQUIREMENTS.

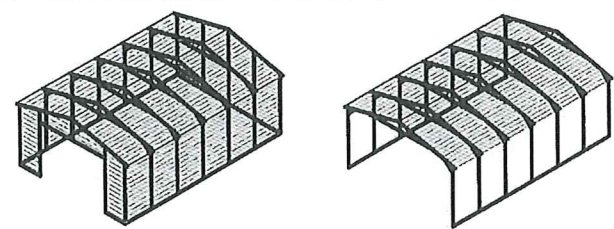

TYP. ENCLOSED BUILDING  
SCALE: NTS

TYP. OPEN BUILDING  
SCALE: NTS

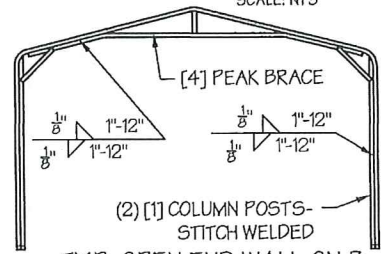

TYP. OPEN END WALL ON 3 SIDE ENCLOSED BUILDING  
SCALE: NTS

**GENERAL NOTES:**

- THE MAX. BUILDING LENGTH FOR ENCLOSED BUILDINGS IS 50'-0". THIS CAN BE INCREASED BY ADDING A DOUBLE FRAME AT THE CENTER TO BREAK THE LENGTH OF THE BUILDING.
- BUILDINGS WITH PARTIALLY ENCLOSED END WALLS NEED TO HAVE SIDE WALL BRACING TO SUPPORT THE PARTIALLY ENCLOSED END WALL. (SEE FIGURE A ON SHEET 5).

MANUFACTURED BY:



457 N. Broadway,  
Joshua, TX 76058  
1-866-730-9865

ENGINEERED BY:



**A&A ENGINEERING**  
CIVIL • STRUCTURAL  
6063 Renaissance Place, Toledo, OH 43623  
Tel. 419-292-1983 • Fax. 419-292-0955  
www.aa-engineers.com

**DRAWING INFORMATION**

PROJECT: 30'-0" WIDE BUILDINGS  
LOCATION: STATE OF OREGON  
PROJECT NO.: 233-23-0070  
SHEET TITLE:

SPACING SCHEDULES  
& ENCLOSURE NOTES

SHEET NO.: 4 / 11  
DRAWN BY: A.W. DATE: 1/25/22  
CHECKED BY: OAA DATE: 1/25/22

**LEGAL INFORMATION**

- ANY DUPLICATION OF THIS DRAWING IN WHOLE OR PART IS STRICTLY FORBIDDEN. ANYONE DOING SO WILL BE PROSECUTED UNDER THE FULL EXTENT OF THE LAW. - DRAWINGS VALID UP TO 1 YEAR FROM DATE OF ISSUE.

SEAL:



STAMP EXPIRY: 12-31-2023  
DATE SIGNED: 01-13-2023



TABLE 5.1: PURLIN SPACING SCHEDULE

GROUND SNOW / ROOF LIVE LOAD (PSF)	14GA. HAT CHANNEL PURLIN						
	WIND SPEED (MPH)						
	105	115	130	140	155	165	180
30/20	54	48	42	36	30	24	24
40/27	42	42	42	36	30	24	24
50/34	40	40	40	36	30	24	24
60/41	36	36	36	36	30	24	24
70/47	32	32	32	32	30	24	24
80/54	30	30	30	30	30	24	24
90/61	24	24	24	24	24	24	24
30/20	54	48	42	42	36	30	30
40/27	42	42	42	42	36	30	30
50/34	40	40	40	40	36	30	30
60/41	36	36	36	36	36	30	30
70/47	32	32	32	32	32	30	30
80/54	32	32	32	32	32	30	30
90/61	30	30	30	30	30	30	30
30/20	54	48	42	42	36	36	30
40/27	42	42	42	42	36	36	30
50/34	40	40	40	40	36	36	30
60/41	36	36	36	36	36	36	30
70/47	32	32	32	32	32	32	30
80/54	32	32	32	32	32	32	30
90/61	30	30	30	30	30	30	30
30/20	54	48	42	42	36	36	30
40/27	42	42	42	42	36	36	30
50/34	40	40	40	40	36	36	30
60/41	36	36	36	36	36	36	30
70/47	32	32	32	32	32	32	30
80/54	32	32	32	32	32	32	30
90/61	30	30	30	30	30	30	30

NOTES:

- PURLIN SPACING UNITS ARE IN INCHES.
- FRAME SPACING NEEDS TO BE DETERMINED FROM TABLE 4.

IRREGULAR BUILDING NOTES:

- FIGURES A, B, C & D ON THE RIGHT INDICATE EXAMPLES OF IRREGULAR BUILDINGS.
- FOR IRREGULAR BUILDINGS, FRAME SPACING MUST BE REDUCED BY 6" FROM OPEN BUILDING SPACING TABLE. SEE SHEET 4 FOR OPEN BUILDING TABLE.
- SITE SPECIFICS MAY ALLOW FOR ALTERNATIVE SPACING.

TABLE 5.2: GIRT SPACING SCHEDULE

FRAME SPACING	WIND SPEED (MPH)						
	105	115	130	140	155	165	180
5'-0"	60	48	36	30	24	24	18
4'-6"	60	60	48	42	36	30	24
4'-0"	60	60	54	54	42	36	30
3'-6"	60	60	54	54	48	42	42
2'-0" TO 3'-0"	60	60	54	54	48	42	42

NOTES:

- GIRT SPACING UNITS ARE IN INCHES.
- THIS SCHEDULE IS TO BE USED FOR BOTH 14GA
- FRAME SPACING NEEDS TO BE DETERMINED FROM TABLE 4.

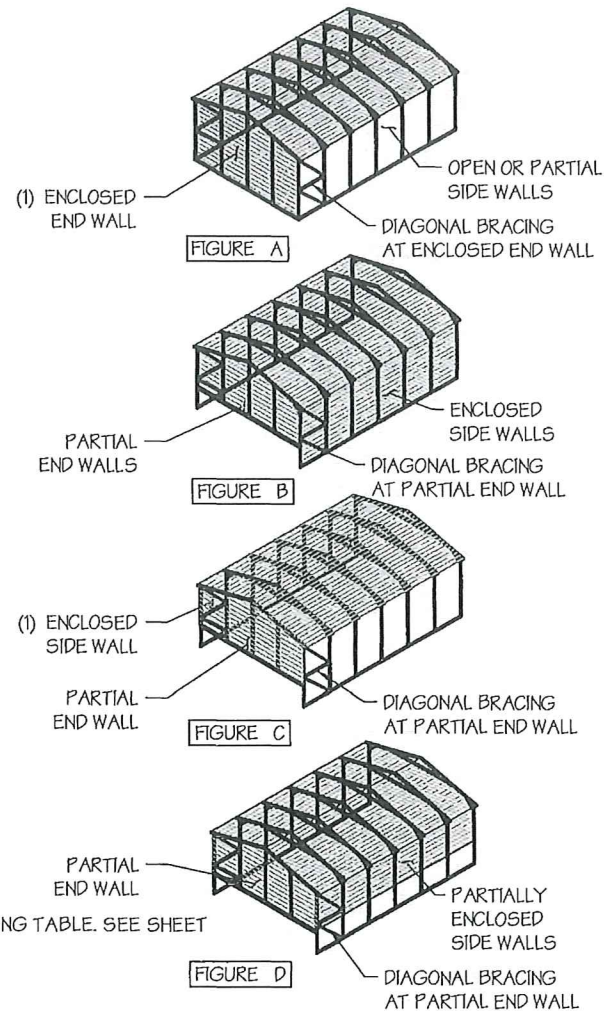

MANUFACTURED BY:



457 N. Broadway,  
Joshua, TX 76058  
1-866-730-9865

ENGINEERED BY:



**A&A ENGINEERING**  
CIVIL • STRUCTURAL  
6063 Renaissance Place, Toledo, OH 43623  
Tel. 419-292-1983 • Fax. 419-292-0955  
www.aa-engineers.com

DRAWING INFORMATION

PROJECT: 30'-0" WIDE BUILDINGS

LOCATION: STATE OF OREGON

PROJECT NO.: 233-23-0070

SHEET TITLE:

PURLIN & GIRT  
SPACING SCHEDULES

SHEET NO.: 5 / 11

DRAWN BY: A.W. DATE: 1/25/22

CHECKED BY: OAA DATE: 1/25/22

LEGAL INFORMATION

- ANY DUPLICATION OF THIS DRAWING IN WHOLE OR PART IS STRICTLY FORBIDDEN. ANYONE DOING SO WILL BE PROSECUTED UNDER THE FULL EXTENT OF THE LAW.  
- DRAWINGS VALID UP TO 1 YEAR FROM DATE OF ISSUE.

SEAL:



STAMP EXPIRY: 12-31-2023

DATE SIGNED: 01-13-2023



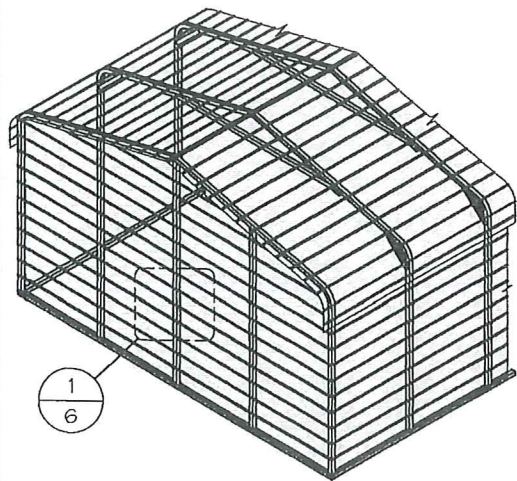

TYP. HORIZONTAL SHEATHING  
SCALE: NTS

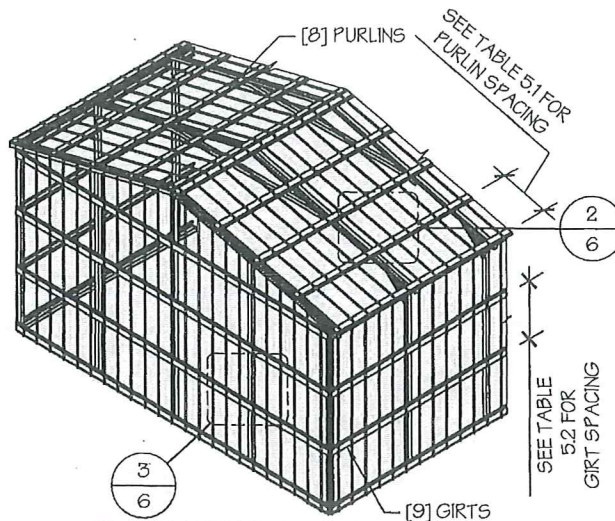

TYP. VERTICAL SHEATHING  
SCALE: NTS

**GENERAL SHEATHING NOTES:**

1. REGULAR STYLE BUILDINGS CAN ONLY HAVE HORIZONTAL SHEATHING ON ROOF AND WALLS.
2. A-FRAME STYLE BUILDINGS CAN HAVE ANY COMBINATION OF HORIZONTAL OR VERTICAL SHEATHING ON ROOFS AND WALLS.
3. BOTH HORIZONTAL AND VERTICALS ROOF SHEATHING CAN HAVE MAX. 6" OVERHANG.
4. USING VERTICAL SHEATHING MAY ALLOW FOR GREATER FRAME SPACING. SEE NOTE 2 UNDER TABLE 4.
5. VERTICAL SHEATHING RECOMMENDED FOR BUILDINGS 30' OR LONGER

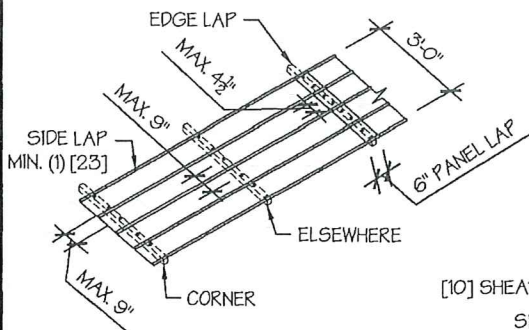

TYP. SHEATHING FASTENER SCHEDULE  
SCALE: NTS

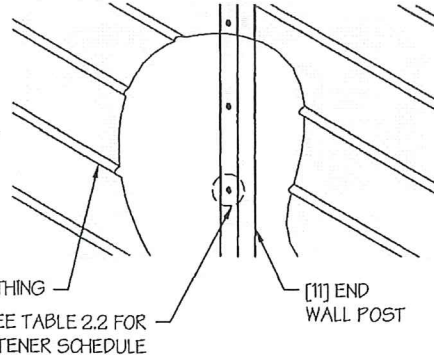

TYP. HORIZONTAL SHEATHING DETAIL 1  
SCALE: NTS

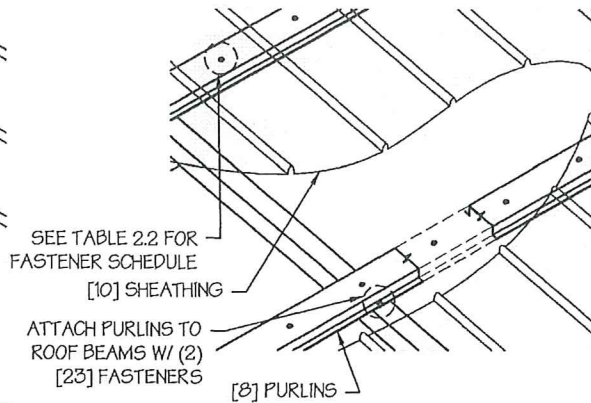

ROOF VERTICAL SHEATHING DETAIL 2  
SCALE: NTS

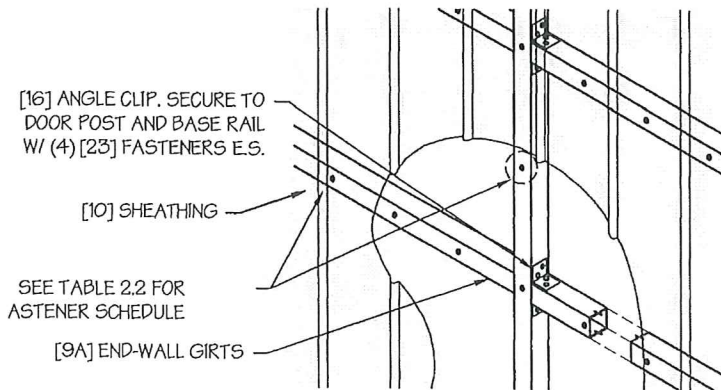

WALL VERTICAL SHEATHING - TUBE DETAIL 3  
SCALE: NTS

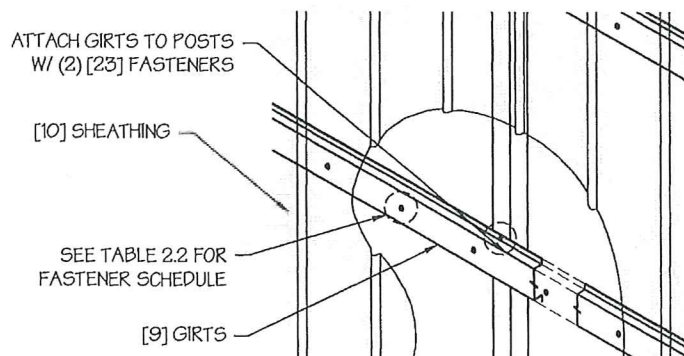

WALL VERTICAL SHEATHING - HAT CHANNEL DETAIL 3  
SCALE: NTS

MANUFACTURED BY:



457 N. Broadway,  
Joshua, TX 76058  
1-866-730-9865

ENGINEERED BY:



A&A ENGINEERING  
CIVIL • STRUCTURAL  
6063 Renaissance Place, Toledo, OH 43623  
Tel. 419-292-1983 • Fax. 419-292-0955  
www.aa-engineers.com

**DRAWING INFORMATION**

PROJECT: 30'-0" WIDE BUILDINGS

LOCATION: STATE OF OREGON

PROJECT NO.: 233-23-0070

SHEET TITLE:

SHEATHING OPTIONS  
& DETAILS

SHEET NO.: 6 / 11

DRAWN BY: A.W. DATE: 1/25/22

CHECKED BY: OAA DATE: 1/25/22

**LEGAL INFORMATION**

- ANY DUPLICATION OF THIS DRAWING IN WHOLE OR PART IS STRICTLY FORBIDDEN. ANYONE DOING SO WILL BE PROSECUTED UNDER THE FULL EXTENT OF THE LAW.  
- DRAWINGS VALID UP TO 1 YEAR FROM DATE OF ISSUE.

SEAL:



STAMP EXPIRY: 12-31-2023

DATE SIGNED: 01-13-2023







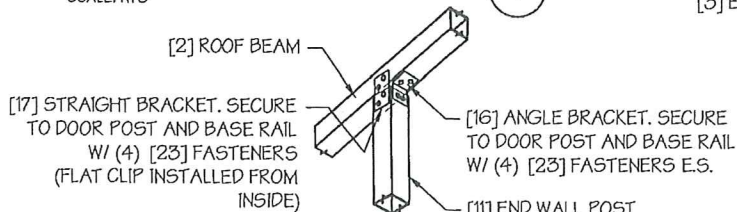
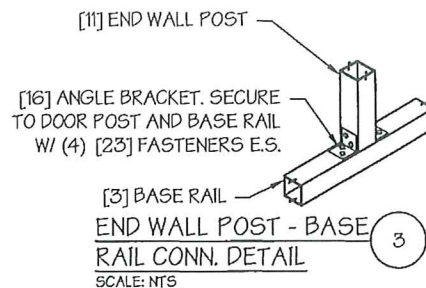
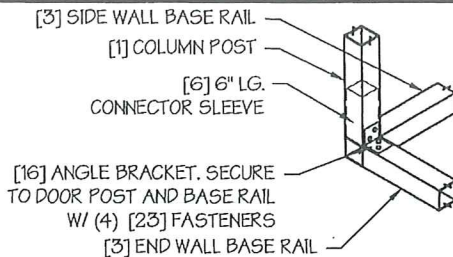
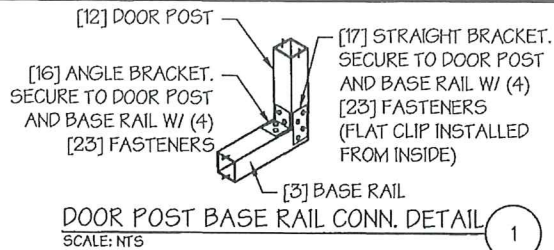

**CORNER DETAIL**  
SCALE: NTS

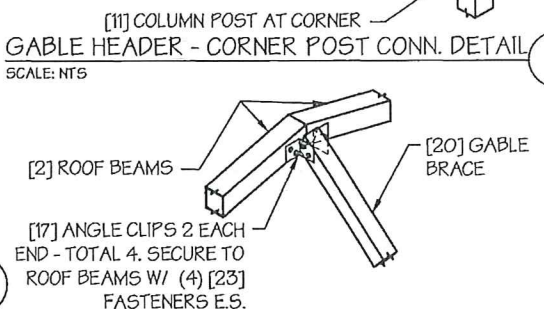
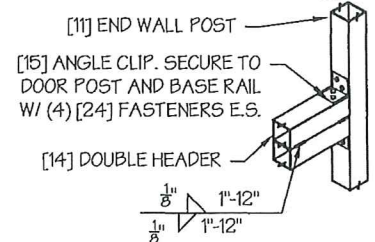
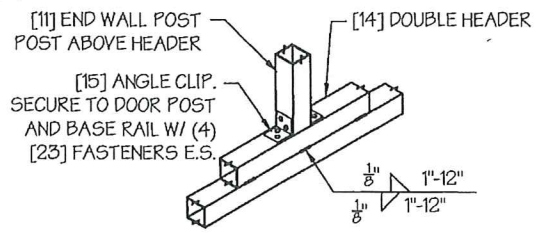
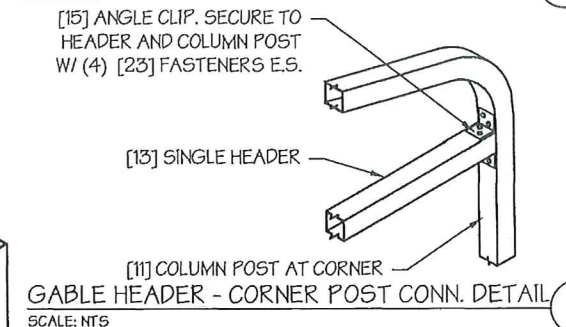
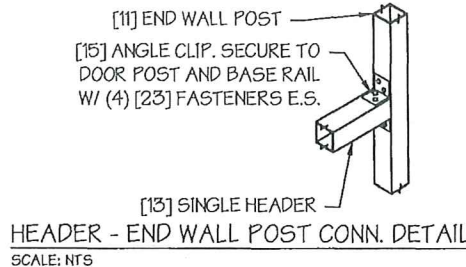
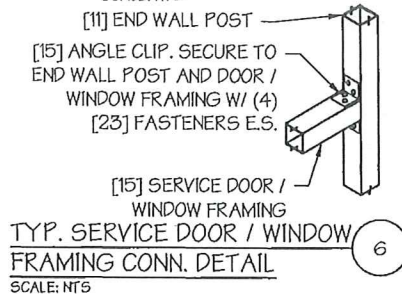
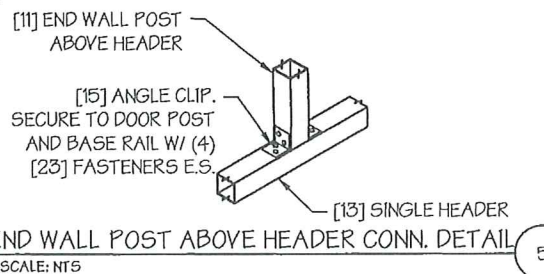

**END WALL POST ABOVE DOUBLE HEADER CONN. DETAIL**  
SCALE: NTS

**DOUBLE HEADER - END WALL POST CONN. DETAIL**  
SCALE: NTS

**TYP. GABLE BRACE CONN. DETAIL**  
SCALE: NTS

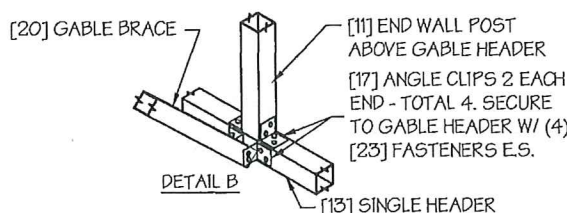
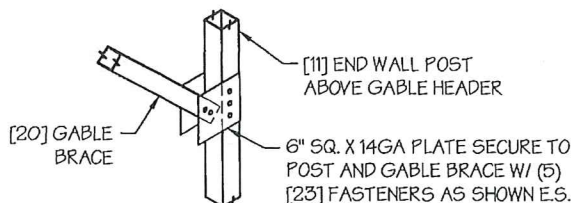

**GABLE BRACE - END WALL CONN. DETAIL**  
SCALE: NTS

**GABLE BRACING NOTE**

- GABLE BRACE IS ONLY REQUIRED FOR PARTIALLY ENCLOSED END WALLS (END WALL POSTS ARE NOT ANCHORED TO THE GROUND).
- FULLY ENCLOSED OR OPEN END WALLS DO NOT REQUIRE GABLE BRACING.

MANUFACTURED BY:

457 N. Broadway,  
Joshua, TX 76058  
1-866-730-9865

ENGINEERED BY:

**A&A ENGINEERING**  
CIVIL • STRUCTURAL  
6063 Renaissance Place, Toledo, OH 43623  
Tel. 419-292-1983 • Fax. 419-292-0955  
www.aa-engineers.com

**DRAWING INFORMATION**

PROJECT: 30'-0" WIDE BUILDINGS  
LOCATION: STATE OF OREGON  
PROJECT NO.: 233-23-0070  
SHEET TITLE:  
**END WALL FRAMING DETAILS**  
SHEET NO.: 8-B / 11  
DRAWN BY: A.W. DATE: 1/25/22  
CHECKED BY: OAA DATE: 1/25/22

**LEGAL INFORMATION**

- ANY DUPLICATION OF THIS DRAWING IN WHOLE OR PART IS STRICTLY FORBIDDEN. ANYONE DOING SO WILL BE PROSECUTED UNDER THE FULL EXTENT OF THE LAW. - DRAWINGS VALID UP TO 1 YEAR FROM DATE OF ISSUE.

SEAL:

STAMP EXPIRY: **12-31-2023**  
DATE STRICT: **01-13-2023**



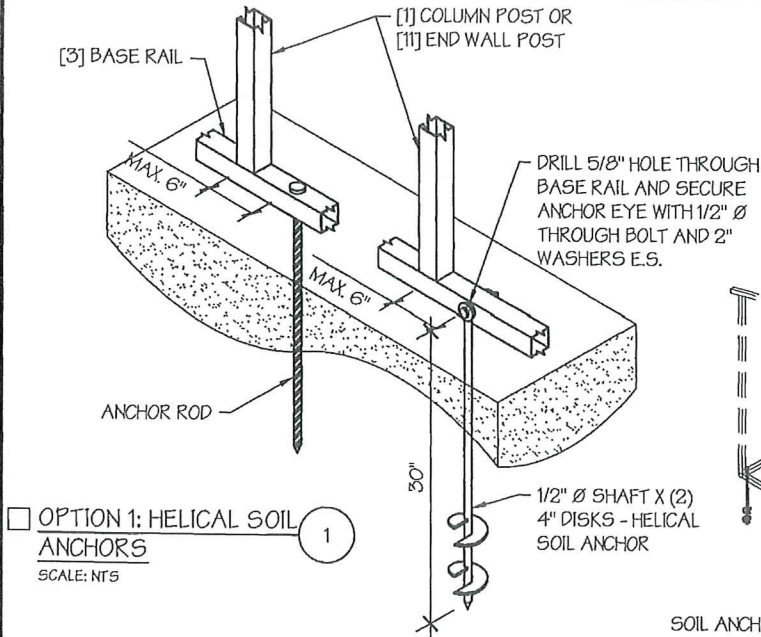

**OPTION 1: HELICAL SOIL ANCHORS**  
SCALE: NTS

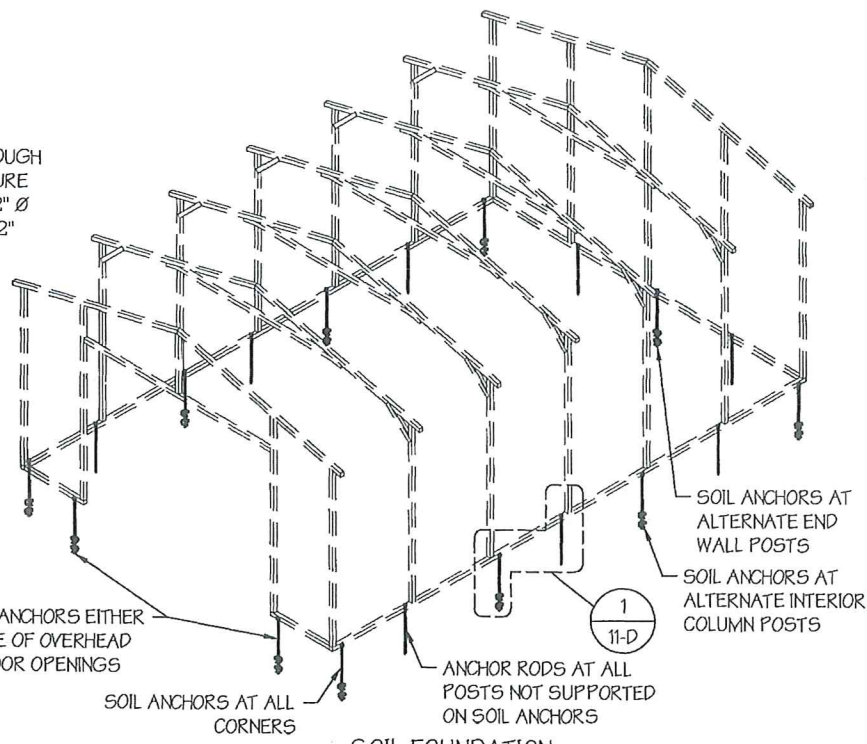

**SOIL FOUNDATION**  
SCALE: NTS

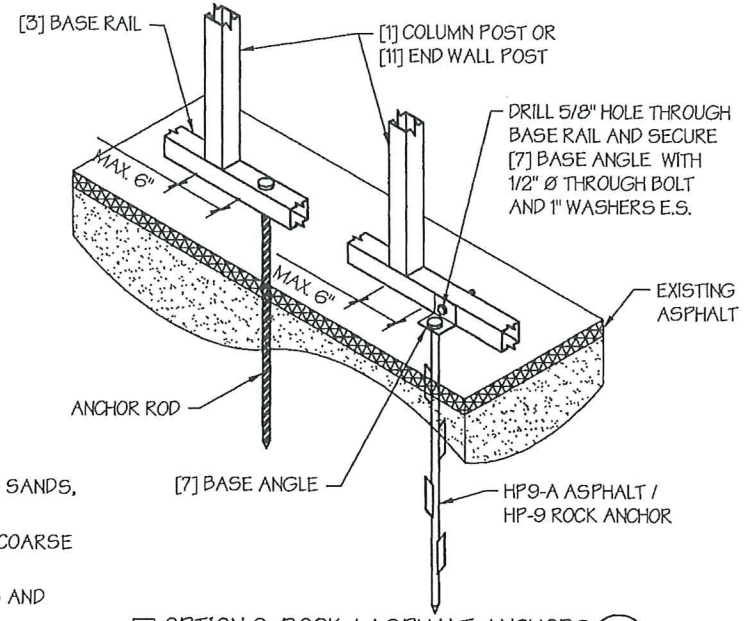

**OPTION 2: ROCK / ASPHALT ANCHORS**  
SCALE: NTS

**SOIL FOUNDATION NOTES:**

- DESIGNS SHOWN ON THIS SHEET ARE FOR SOIL ANCHOR FOUNDATION.
- SOIL ANCHORS (HELICAL OR ROCK/ASPHALT) SHALL BE LOCATED AT ALL 4 CORNERS, ON EACH SIDE OF OVERHEAD DOOR OPENINGS, ON POSTS WITH DIAGONAL BRACING IF REQUIRED, AND ON ALTERNATE INTERIOR COLUMN POSTS AND END WALLS POSTS.
- HELICAL ANCHORS ARE TO BE USED ONLY IF THE DRIVING TORQUE INTO THE GROUND IS 150 FT-LBS OR GREATER. MANUFACTURER IS NOT RESPONSIBLE FOR SOIL QUALITY AT SITE.
- HELICAL ANCHORS CAN ONLY BE USED FOR CLASS 2, 3 & 4 SOILS (SEE SOIL CLASSIFICATIONS THIS PAGE).
- ALL POSTS WITH NO ANCHORS ADJACENT SHALL BE ANCHORED TO THE GROUND WITH A 1/2" X 30" LG. ROD. RODS WILL HAVE A PRE-FORMED HEAD AT THE TOP AND ONE COAT OF RUST PROOF MATERIAL.
- ASSUMED SOIL BEARING CAPACITY IS TO BE A MIN. OF 1500 PSF.

**SOIL CLASSIFICATIONS:**

SOIL CLASS	DESCRIPTION
2	SANDY GRAVEL AND GRAVEL, VERY THIN DENSE AND/OR CEMENTED SANDS, COARSE GRAVEL/COBBLES, PRELOADED SILTS, CLAYS AND CORAL.
3	SAND, SILTY SAND, CLAYEY SAND, SILTY GRAVEL, MEDIUM DENSE COARSE SANDS, SANDY GRAVEL, VERY STIFF SILT AND SANDY CLAYS.
4	LOOSE TO MEDIUM DENSE SANDS, FIRM TO STIFF CLAYS AND SILTS AND ALLUVIAL FILLS.

\*FROM HUD "MODEL MANUFACTURED HOME INSTALLATION STANDARDS"

MANUFACTURED BY:



457 N. Broadway,  
Joshua, TX 76058  
1-866-730-9865

ENGINEERED BY:



**A&A ENGINEERING**  
CIVIL • STRUCTURAL  
6063 Renaissance Place, Toledo, OH 43623  
Tel. 419-292-1983 • Fax. 419-292-0955  
www.aa-engineers.com

**DRAWING INFORMATION**

PROJECT: 30'-0" WIDE BUILDINGS

LOCATION: STATE OF OREGON

PROJECT NO.: 233-23-0070

SHEET TITLE: FOUNDATION OPTION 4: SOIL ANCHORS

SHEET NO.: 11-D / 11

DRAWN BY: A.W. DATE: 1/25/22

CHECKED BY: OAA DATE: 1/25/22

**LEGAL INFORMATION**

- ANY DUPLICATION OF THIS DRAWING IN WHOLE OR PART IS STRICTLY FORBIDDEN. ANYONE DOING SO WILL BE PROSECUTED UNDER THE FULL EXTENT OF THE LAW. - DRAWINGS VALID UP TO 1 YEAR FROM DATE OF ISSUE.

SEAL:

STAMP EXPIRY: **12-31-2023**  
DATE SIGNED: **01-13-2023**