





# LEGEND





## CONTROLLERS

-  RETAIN AND PROTECT EXISTING TRAFFIC SIGNAL CONTROLLER CABINET
-  RETAIN AND PROTECT EXISTING TERMINAL CABINET





## POLES

-  RETAIN AND PROTECT EXISTING TRAFFIC SIGNAL MAST ARM
-  RETAIN AND PROTECT EXISTING MAST ARM POLE
-  INSTALL PEDESTRIAN SIGNAL PEDESTAL WITH FRANGIBLE BASE

## SIGNALS

-  RETAIN AND PROTECT EXISTING (Ph=PHASE) VEHICLE SIGNAL
-  REMOVE EXISTING PEDESTRIAN SIGNAL, PUSHBUTTON, AND INSTRUCTION SIGN
-  INSTALL PHASE (Ph=phase) COUNTDOWN PEDESTRIAN SIGNAL WITH AUDIBLE PEDESTRIAN SIGNAL PUSHBUTTON
-  INSTALL PHASE (Ph=phase) COUNTDOWN PEDESTRIAN SIGNAL
-  INSTALL PHASE (Ph=phase) AUDIBLE PEDESTRIAN SIGNAL PUSHBUTTON



## JUNCTION BOXES

-  RETAIN AND PROTECT EXISTING JUNCTION BOX
-  REMOVE EXISTING JUNCTION BOX
-  INSTALL (T=TYPE) JUNCTION BOX. SEE ODOT STANDARD DRAWING TM472 FOR TYPES AND DIMENSIONS
-  RETAIN AND PROTECT EXISTING SAND POCKET
-  INSTALL 6" MAX SAND POCKET BLOCK-OUT WITH (S=SIZE) INCH CONDUIT TO JUNCTION BOX



## FIRE PREEMPTION

-  RETAIN AND PROTECT EXISTING FIRE PREEMPTION DETECTOR UNIT



## CONDUITS

-  RETAIN AND PROTECT EXISTING (S=SIZE WHEN SHOWN) INCH ELECTRICAL CONDUIT
-  RETAIN AND PROTECT EXISTING (S=SIZE WHEN SHOWN) INCH DETECTOR CONDUIT
-  INSTALL SIZE (S=size) INCH CONDUIT









## WIRES & CABLES

-  RETAIN AND PROTECT EXISTING WIRING
-  INSTALL (N) NO. 8 TYPE THWN (SIGNAL SYSTEM COMMON)
-  INSTALL (N) NO. (G) TYPE THWN WIRES

## ILLUMINATION

-  EXISTING LIGHT POLE, LUMINAIRE, AND MAST ARM TO BE REMOVED BY OTHERS. SEE ILLUMINATION PLAN.
-  INSTALL LIGHT POLE WITH 135 WATT LED LUMINAIRE AND SPECIFIED MAST ARM. SEE ILLUMINATION PLAN.

## DETECTION

-  RETAIN AND PROTECT EXISTING VEHICLE DETECTOR LOOP
-  RETAIN AND PROTECT EXISTING BICYCLE DETECTOR LOOP
-  ABANDON EXISTING BICYCLE DETECTOR LOOP
-  ABANDON EXISTING VEHICLE DETECTOR LOOP
-  INSTALL PHASE (Ph=phase) BICYCLE DETECTOR LOOP
-  INSTALL PHASE (Ph=phase) VEHICLE DETECTOR LOOP
-  EXISTING PAIR OF LOOP WIRES
-  INSTALL (N=number) PAIR OF LOOP WIRES

## ORIENTATION DIAGRAM

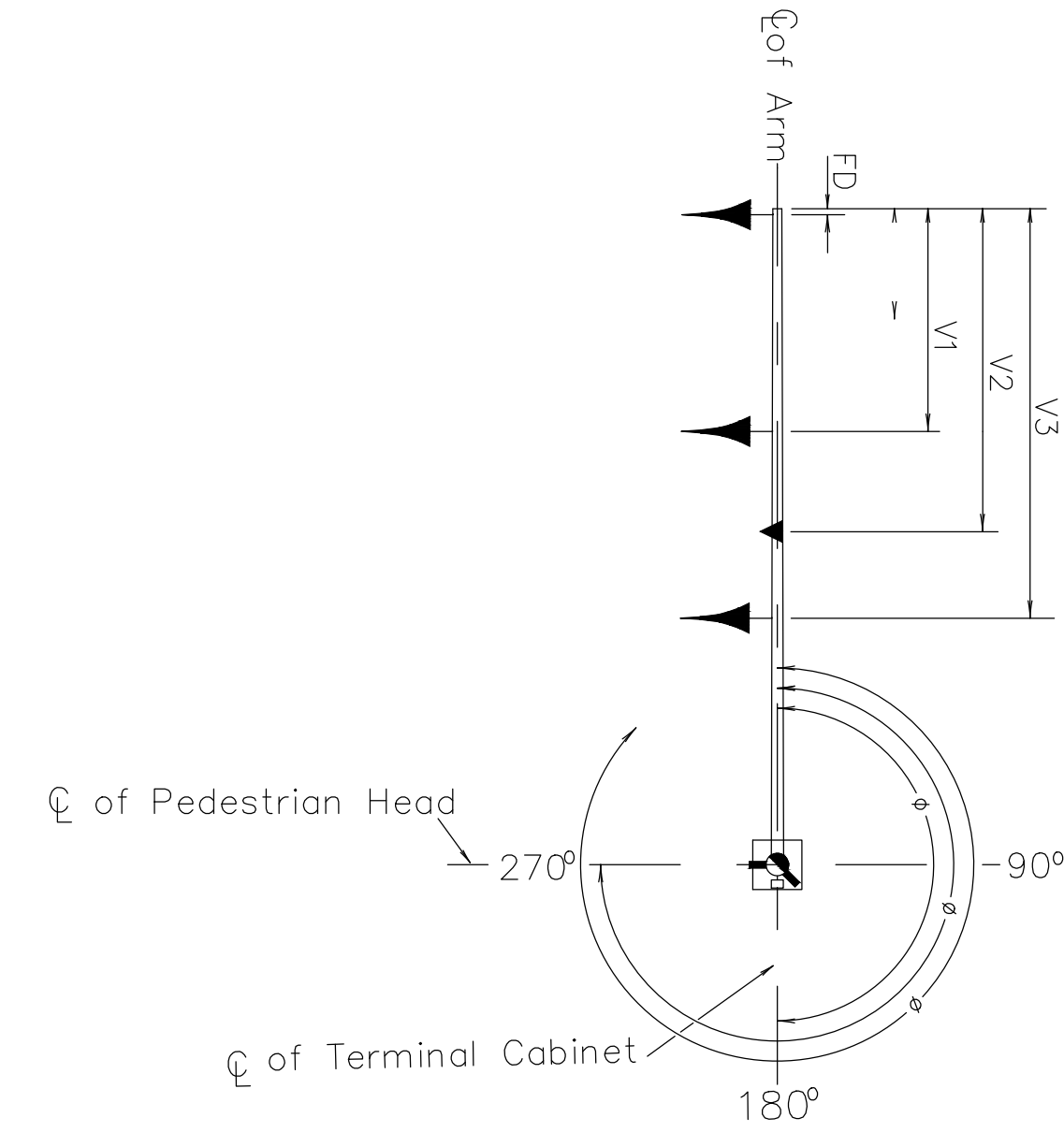

**lancaster  
moble**

321 SW 4th Avenue  
Portland, OR 97204  
(503)-248-0313  
lancastermoble.com



EXPIRES 12/31/2024

REVISIONS	By:	By:	By:
Rev:			
Des:			
Rev:			
Des:			
Rev:			
Des:			

**QUEEN AVENUE REHABILITATION**  
**QUEEN AVE & ELM ST**  
 Signal Modification Legend  
 Albany, Oregon

Job No. 22075  
 Designed By: JLH  
 Drawn By: JLH  
 Checked By: TEM  
 Date: 1/6/23

**T1**

POLE ENTRANCE CHART

POLE NO.	TYPE	EQUIPMENT ON POLE					EQUIPMENT ON MAST ARM DISTANCE FROM THE END OF MAST ARM			
		MAST ARM ORIENTATION	LUMINAIRE ORIENTATION	TERM CABINET DEGREE	PED PUSHBUTTON DEGREE	PED SIGNAL DEGREE	ARM LENGTH	FIRE PREEMPTION	V1	V2
1	MAP	EX	-	EX	-	-	25	EX	EX	EX
2	PP	-	-	-	270	270	-	-	-	-
3	PP	-	-	-	0	0	-	-	-	-
4	PP	-	-	-	270	270	-	-	-	-
5	PP	-	-	-	0	0	-	-	-	-
6	MAP	EX	-	EX	-	-	35	EX	EX	EX
7	MAP	EX	-	EX	-	-	20	EX	EX	EX
8	PP	-	-	-	270, 0	270, 0	-	-	-	-
9	MAP	EX	-	EX	270	270	35	EX	EX	EX
10	PP	-	-	-	0	0	-	-	-	-

NORMAL PHASE ROTATION DIAGRAM

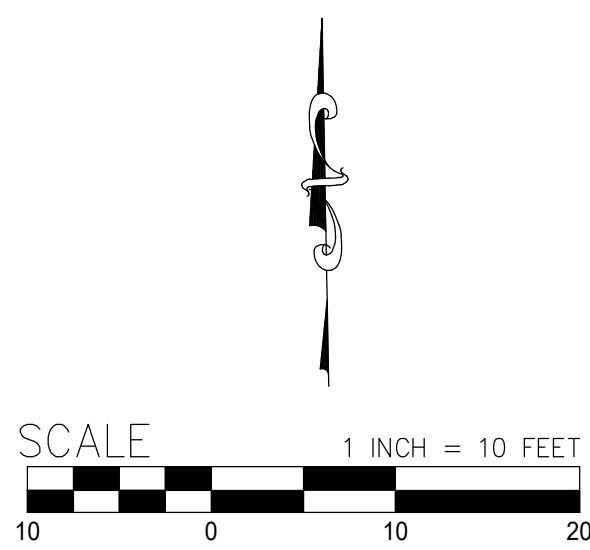
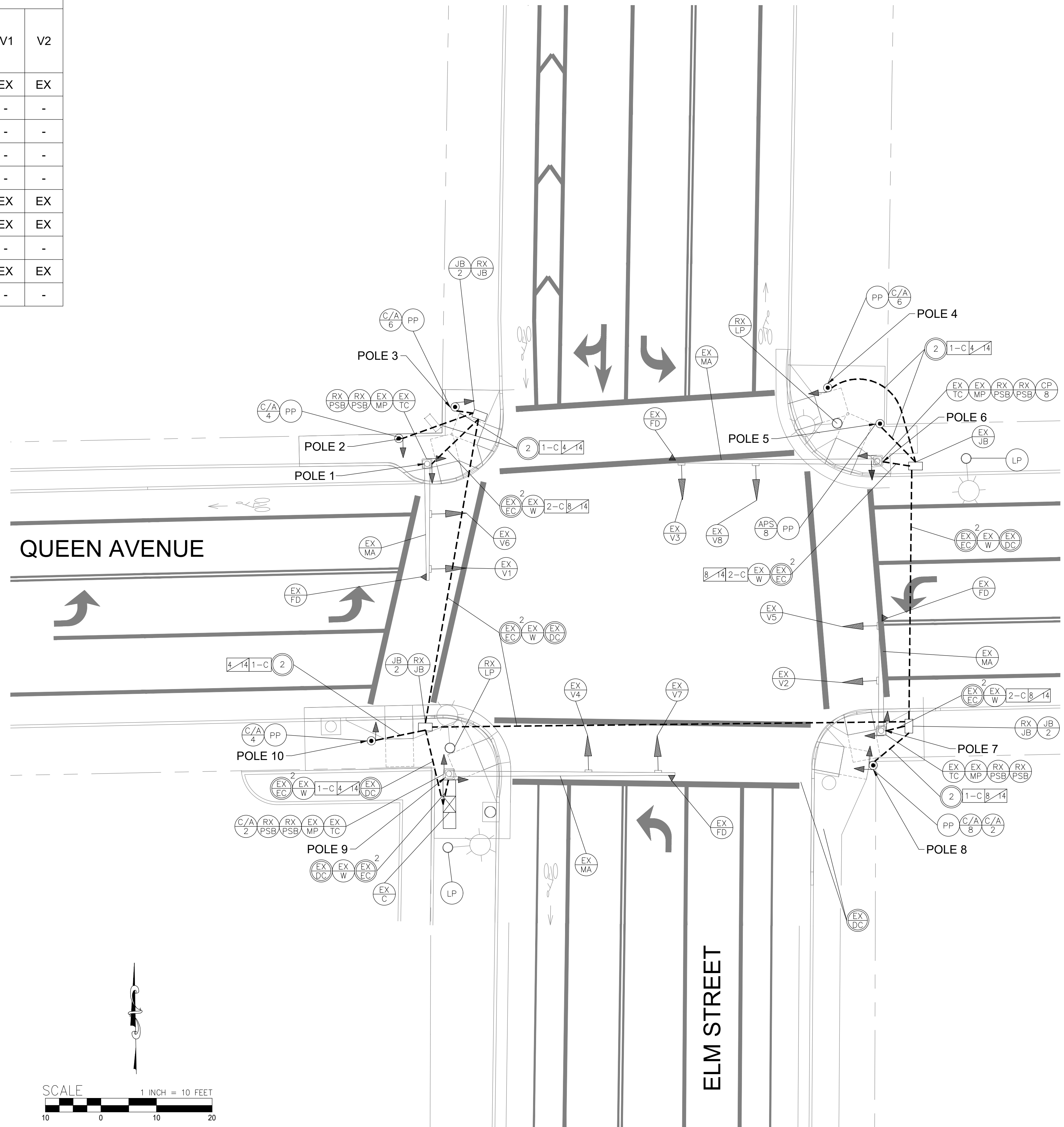
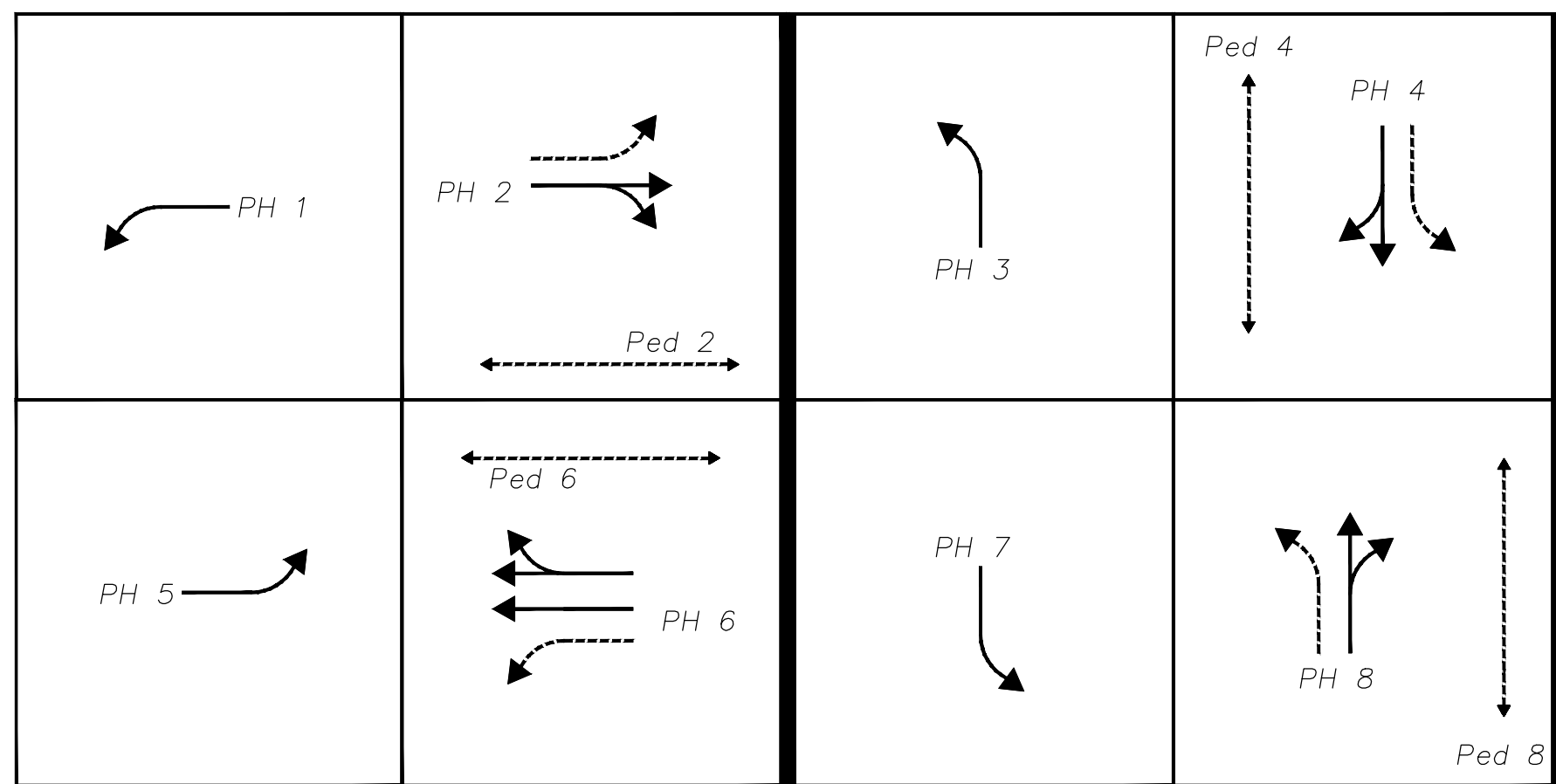

**lancaster  
moble**

321 SW 4th Avenue  
Portland, OR 97204  
(503)-248-0313  
lancastermoble.com



EXPIRES 12/31/2024

REVISIONS

Rev.	By:	Des:

**QUEEN AVENUE REHABILITATION  
QUEEN AVE AT ELM ST**  
Signal Modification Plan  
Albany, Oregon

Job No. 22075  
Designed By: JLH  
Drawn By: JLH  
Checked By: TEM  
Date: 1/6/23

**T2**

