



ALBANY REVITALIZATION AGENCY AGENDA

Wednesday, May 27, 2026

4:00 p.m.

Albany City Council Chambers

333 Broadalbin Street SW

ARA Zoom link for public participation: <https://albanyoregon.gov/council/groups/ara/zoom>,

Phone: 253-215-8782 | Meeting ID: 893 9379 2719 | Passcode: 12379

Please help us get Albany's work done.

Be respectful and refer to the rules of conduct posted by the main door to the Chambers and on the website.

1. Call to Order
2. Roll Call
3. Approval of Minutes:
 - April 22, 2026 [Pages 2-4]
4. Public Comment

Persons wanting to provide comments may:

 - 1- *Email written comments to sophie.adams@albanyoregon.gov, including your name before noon on the day of the meeting.*
 - 2- *To comment virtually during the meeting, register by emailing sophie.adams@albanyoregon.gov before noon on the day of the meeting, with your name. The chair will call upon those who have registered to speak.*
 - 3- *Appear in person at the meeting and register to speak.*
5. Scheduled Business
 - Central Albany Revitalization Area (CARA) Grant Program [Pages 5-307]
 - Recess to Executive Session to Discuss Real Property Transactions in Accordance with ORS 192.660(2)(e)
 - 300 W First Avenue Development Discussion [Pages 308-309]
6. Staff Updates
7. Business from the Agency
8. Next Meeting Date: TBD
9. Adjournment

This meeting is accessible to the public via video connection. The location for in-person attendance is accessible to people with disabilities. If you have a disability that requires accommodation, please notify city staff at least 48 hours in advance of the meeting at: sophie.adams@albanyoregon.gov or call 541-917-7654.

Testimony provided at the meeting is part of the public record. Meetings are recorded, capturing both in-person and virtual participation, and are posted on the City website.

albanyoregon.gov





MINUTES

Wednesday, April 22, 2026

4:00 p.m.

Hybrid-Council Chambers, City Hall

Approved: DRAFT

Call to Order

Chair Newton called the meeting to order at 4:00 p.m.

Roll Call

Members present: Present were Chair Steph Newton, and Members Carolyn McLeod, Marilyn Smith, Ramycia McGhee, Alex Johnson. Chris Van Drimmelen arrived at 4:03 p.m. and Michael Thomson arrived at 4:11 p.m.

Members absent: None

Approval of Minutes: 4:02 p.m.

- January 28, 2026

Motion: McGhee moved to approve the minutes. Smith seconded the motion which passed 7-0.

Public Comment 4:03 p.m.

Chris Scariano from Edwards Jones spoke briefly on the significance of Sybaris in the community. Liz Rapp spoke of her support of the Hackleman District and how Sybaris could improve that area. Lisa Grato was thankful to Sybaris for restoring the train station. Tad Davies went into detail on how Sybaris will improve that area of town. Kathleen Tory, member of Grand Ronde, expressed her support in Sybaris. Courtney Poutlot spoke on behalf of ABC House also shared her support of Sybaris.

Scheduled Business 4:25 p.m.

Central Albany Revitalization Area (CARA) Grant Program
Economic Development Manager, Sophie Adams started the session providing slides* and an overview of the CARA Grant, including the total amount available, application window and other applicant requirements, what constitutes an eligible project and the key objectives of the CARA program. She walked through the review process for the applications and the format for the meeting. She added a few options to the committee as they decide how funds could be awarded. It was asked that the committee members disclose any site visits, biases, or conflicts of interest before moving into the presentations. All members disclosed that they visited all the sites on numerous occasions.

111 W 1st Avenue – Josh Mitchell – Albany Civic Theater – Project includes the front doors, crown crest across front and mural on west wall, which is viewable from the bridge.



133 5th Avenue SE – Matt and Janel Bennett – Sybaris Train Station – Improving the Hackleman District. Ryan McAllister – Project includes the conference room, restrooms, back patio w/fireplace.

140 NE Hill Street – Caitlin Prueitt - Calapooia Brewery – Replacement of windows in pub and barbershop.

212 1st Avenue E – Josh Oare – Shultz Building – Plans to open Titan Valley Brewery - Exterior restoration to preserve the building.

230 Lyons Street S – Darin Clowser – The building houses multiple businesses and apartments – Replace middle windows.

241 W 1st Avenue – James Carmichael – Venetian Theater/Grove Church – A flexible space for church and community functions, through-out the week.

333 1st Avenue W - Jim and Corina Abbott – John Briggs Building – Renovating it to house 4 apartments and a commercial space on the first floor.

343 1st Avenue – John Pascone – Peterson Bldg – Murphy Seed Store – Needing to replace the sewer lines

635 NE Water Avenue – Eric & Jaime Howard – Owners of Deluxe Brewing Co – Replace west end windows and upgrade bathrooms and add ADA bathroom.

975 Ellsworth Street SW – Nate McDonald with McDonald Properties – Furniture Share Thrift Store – Needs change of use to retail, add ADA bathrooms, electrical upgrades and structural improvements.

1400 Santiam Road SE – Alex Rice - Cumberland Community Event Center – Need funds to pay for system development charges and hooking up to city services.

1550 Salem Avenue SE – Joshua Mitchell – Construction company – zoned residential but has been used exclusively as commercial. Upgrade exterior, from current metal siding, which will improve look and increase energy efficiency.

Questions to applicants

5:06 p.m.

The committee then went back through the list of applicants, to ask questions. The group discussed several of the applications, asking staff and the applicants questions to clarify the specific needs of the projects. They also made a point to thank all of the public comments. They also noted that they were impressed with the number of applicants and their interest in improving these areas.

Member Johnson noted that the City Council meeting was scheduled in 20 minutes, which would not provide much time. There were mentions of re-convening after the City Council or to continue at the next CARA meeting in May. It was decided to move forward with the meeting and make as much progress as possible.

Motion: Member Thomson made a motion to approve the request from applicant number two, the Oregon Electric Railway Building at 133 5th Avenue SE, in the amount of \$421,770. Motion was seconded by Member McLoed. Member Newton said that because she had done some work for Sybris Bistro and had volunteered at events that they hosted, she would recuse herself from voting unless there was a tie vote. There was a call for discussion, including if the group could get through the remaining applications,

recognizing that while this was a huge win for historic preservation there was concern that with this single largest request it leaves far less for the remaining deserving projects. Other mentions included that granting this would complete the funding needs for the applicant and would be good for the Hackleman District, Member Van Drimmelen asked that awarding a partial amount of \$261,940, would fund the renovations to the patio. There was follow-up from Member Thomson, encouraging the group to vote yes for the full amount and he then requested to call for the vote. Verbal vote failed. Member Thomson called division on the vote and asked for a roll call vote.

Yes - Thomson and McLoed

No - Van Drimmelen, McGhee, Smith and Johnson

Abstain - Newton

Motion: Member VanDrimmelen moved to partially fund the request from 133 5th Avenue SE, in the amount of \$261,940. Seconded by Smith. Roll Vote was requested by McGhee.

Yes - Van Drimmelen, McGhee, Smith, Johnson and McLoed

No - Thomson

Abstain – Newton

Member Van Drimmelen pointed out that if they come to the end of the discussion and it becomes clear to the body that there is more money to put toward any project, there is nothing that would stop the group from passing another motion to add funds to anything they have already partially funded as well.

Adams then noted that it would be appropriate to adjourn and pick the conversation up at the May 27th meeting.

Motion to Adjourn: Van Drimmelen moved to adjourn. McLeod seconded the motion, which passed 7-0.

Next meeting dates

Monday, May 27, 2026

Respectfully submitted,

Reviewed by,

Talley Richardson
Administrative Assistant I

Sophie Adams
Economic Development Manager

**Documents discussed at the meeting that are not in the agenda packet are archived in the record. Documents from staff are posted to the website after the meeting. Documents submitted by the public are available by emailing cityrecorder@albanyoregon.gov.*



TO: Albany Revitalization Agency (ARA)
FROM: Sophie Adams, Economic Development Manager
DATE: May 20, 2026 for the May 27, 2026, ARA Meeting

SUBJECT: Grant Evaluation and Awards

Purpose:

Review Central Albany Revitalization Area (CARA) grant applications, discuss, and make awards.

Background/Discussion:

The Central Albany Revitalization Area Urban Renewal Plan (“Plan”) was adopted in August 2001. Its boundary encompasses 986 acres in the City of Albany, about nine percent of the total City acreage. The Plan identified a range of programs and capital projects to be carried out by CARA, including development partnerships, public space improvements, infrastructure, pedestrian/bike connectivity projects, community facilities, and technical support.

CARA Key Objectives:

- Attract new private investment to the area.
- Retain and enhance the value of existing private investment and public investment in the area.

In November 2025, the ARA met for a facilitated discussion with Tiberius Solutions to review progress towards maximum indebtedness and provide guidance for spending the remaining CARA funds, with a goal of closing the district in 2027. At that time, the Agency directed staff to re-establish the former general CARA Grant program, with a total award amount of \$545,000.

Below is a table showing timelines and milestones of the “new” grant program.

Date	Milestone / Activity
November 19, 2025	ARA direction to re-open previous CARA Grant program
January 28, 2026	ARA meeting to review CARA program details and schedule
February 6, 2026	Grant information posted on website, social media, city newsletters, and shared via other methods
February 6, 2026	Grant application window opened
February 17, 2026	In-person grant info session hosted at City Hall (approx. 20 attendees)

Date	Milestone / Activity
March 31, 2026	Grant application window closed
March 31 – April 10, 2026	Staff review and agenda preparation
April 13, 2026	Agendas with applications provided to ARA and public for review

A total of thirteen (13) applications were received by the deadline. Twelve (12) of those met the minimum requirements for completeness, meaning they addressed the 25% match and included the required minimum of two (2) bids/cost estimates. A table summary of these applications is below, listed by provided address:

Project Address	Request Amount
111 W 1st Avenue	\$108,000.00
133 5th Avenue SE	\$421,770.00
140 NE Hill Street	\$45,907.00
212 1st Avenue E	\$36,700.00
230 Lyons Street S	\$71,655.00
241 W 1st Avenue	\$150,000.00
333 1st Avenue W	\$281,357.21
343 1st Avenue	\$9,720.00
635 NE Water Avenue	\$85,900.00
975 Ellsworth Street	\$75,000.00
1400 Santiam Road SE	\$109,100.00
1550 Salem Avenue	\$71,107.00
Total	\$1,466,216.21

To aid in the Agency’s deliberation, staff completed a Project Evaluation Grid for each project, attached to the end of each application included in this packet. These evaluations objectively compare application information with ARA-approved criteria. They do not score or rank projects, and staff do not provide recommendations for one project over another.

All projects meet the goals and objectives of the CARA district, align with statutory spending requirements for urban renewal dollars, and accomplish at least one of the activities within the CARA Plan.

Given the competitive nature of this program, the Agency may want to consider the following points while evaluating applications:

- Is this project critical to the preservation or viability of a sensitive or historic property?
- Is this project critical to the success of an existing or incoming business?
- Make partial awards to spread funding across more projects

Upcoming and next steps:

April 22, 2026	ARA evaluation, discussion, and awards
April 22 – May 8, 2026	Target timeline for finalizing contracts with grantees
May 8, 2026 – May 1, 2027	Project completion window
May 1 – June 30, 2027	Project verification, contract close-out, reporting

Strategic Plan Impact:

The CARA Grant program supports the Healthy Economy section of the current Strategic Plan, specifically Goal 4: Create a readily identifiable downtown core that is unique and vibrant with a mixture of entertainment, housing, specialty shops, offices, and other commercial uses.

Budget/Staff Impact:

Funding and staff support for this grant program is accounted for in the 2025-2027 ARA Adopted Budget. Up to \$545,000 may be expended before the program ends in June 2027.

Staff Recommendation:

Evaluate and approve, by motion, CARA Grant awards up to a total of \$545,000.

Attachments:

1. CARA Grant Applications and corresponding project evaluation grids



CARA GRANT APPLICATION

1. APPLICANT

Name: Albany Civic Theater

Mailing Address: 111 W 1st Ave

Albany, OR Zip Code: 97321

Title: Facilities Coordinator Phone Number: [REDACTED]

E-mail Address: [REDACTED]

2. BUSINESS/BUILDING INFORMATION

Legal Business Name: Albany Civic Theater Inc

Number of Years in Operation: 75

Legal Form: Sole Proprietorship Partnership Corporation S-Corp LLC
 Profit Nonprofit

EIN: [REDACTED]

In which state are the incorporation and/or organization documents filed? Oregon

Have you ever filed for bankruptcy? Yes No

Project Address (if different than mailing address): _____

Property Tax Account Number: 0080958

Is the building a historic contributing resource? Yes No

If so, is it on the historic property-tax freeze? Yes No

3. OWNER OF PROPERTY (if not applicant)

Name in which title is held: Albany Civic Theater, Inc.

Contact Name: Doug Moxley - President

Mailing Address: [REDACTED]

[REDACTED] Zip Code: [REDACTED]

Phone Number: [REDACTED]

4. AUTHORIZATION TO UNDERTAKE WORK:

If the applicant is not the owner of the property, provide written evidence that the owner authorizes this work to be undertaken. (Typically this is in the form of a lease or other written permission.)

5. DESCRIPTION OF PROJECT *Please give a comprehensive description of project.*

We propose two complementary projects to enhance the Albany Civic Theater and strengthen its presence in downtown Albany.

Our first project involves upgrading the auditorium entrance to improve security, accessibility, and aesthetic appeal. Two new crash doors will be installed, positioned approximately 2-3 feet forward from the existing doorway, creating additional space in the foyer for ADA improvements while keeping the sidewalk clear. The doors will meet State Historic Preservation Office standards and feature solid core construction for enhanced security. We will also update exterior lighting along the front entrance to improve safety and install a new metallic ornamental crown on the main awning—inspired by the historic Rialto Theater—to prominently identify the theater and its main entrance. Together, these enhancements will significantly improve public safety, security, and the building's exterior appearance.

Our second project involves commissioning a mural for the theater's west exterior wall, which faces the Ellsworth Bridge and the public parking lot. This wall presents a unique opportunity: some 12,000 vehicles cross the bridge from Highway 20 into Albany daily, with 93% being passenger vehicles. The mural will feature vibrant imagery celebrating Albany Civic Theater, our passion for the arts and live theater, and Albany's historic downtown character—creating a striking "Welcome to Albany" landmark. This project will enrich the city's visual landscape, raise the theater's profile, and draw attention to surrounding businesses and the broader community. A portion of our existing Oregon Main Street Revitalization Grant supports structural repairs and reinforcement of this wall, allowing this mural project to maximize its impact.

6. TIMELINE FOR COMPLETION OF PROJECT: April 2027

7. PROJECT COSTS

ESTIMATED COST OF PROJECT: \$ 144,000

ESTIMATED VALUE OF PROJECT UPON COMPLETION: \$ \$600,000

Basis for valuation and value upon completion: The new entry would add immense curb appeal and functionality to our building.

Also, The Philadelphia Mural Arts Program showed an increase of 15% to property values within one block over in 2 years.

SOURCES FOR PROJECT:

Owner/Company Contribution	<u>\$ 36,000</u>
Bank (estimated)	<u>\$ _____</u>
Other private funds (please specify)	<u>\$ _____</u>
Other governmental (please specify)	<u>\$ _____</u>
CARA (proposed)	<u>\$ 108,000</u>
TOTAL SOURCES	<u>\$ _____</u>

Is your funding for these: available today applied for unknown at this time

USES FOR PROJECT:

Land and/or Building Acquisition	<u>\$ 0</u>
Soft Costs (architectural, engineering, financing, and legal fees, and other pre- and post-construction expenses.) *	<u>\$ 2,000</u>
Construction Costs *	<u>\$ 40,000</u>
Tenant Improvements	<u>\$ 0</u>
Machinery/Equipment/Installation Costs	<u>\$ 102,000</u>
Working Capital	<u>\$ 0</u>
Other (please specify)	<u>\$ 0</u>
TOTAL USES	<u>\$ 144,000</u>

*Please provide a detail of Soft Costs and of Construction Costs (Please attach).

8. PREPARATION OF COST ESTIMATES

Who prepared your cost estimates? River City Design & Build

(If applicant prepared their own estimate, verification may be required. **Please attach minimum of two bids, preferably three.**)

Mailing Address: [REDACTED]

Phone Number: [REDACTED] E-mail Address: [REDACTED]

9A. EXPLAIN WHY CARA FUNDING IS NECESSARY TO INSURE PROJECT COMPLETION.

(Please provide a description of the financial gap requiring CARA assistance.)

Albany Civic Theater requires CARA funding to complete the proposed entrance and mural projects while fulfilling our existing financial commitments.

We are currently undertaking a significant remodel project funded by the Oregon Main Street Revitalization Grant (OMSRG). This grant requires a match of over \$260,000 in cash and volunteer hours—a substantial commitment that has already stretched our resources as a fully volunteer-operated nonprofit. While we are grateful for the OMSRG opportunity and are committed to completing the necessary structural repairs, committing an additional \$144,000 in cash for the proposed projects would exceed our financial capacity.

As careful stewards of our limited resources, we must balance our obligations to the OMSRG match while advancing these critical improvements to security, accessibility, and community presence. CARA funding would bridge this financial gap, enabling us to complete both projects without compromising our fiscal sustainability or ability to meet existing OMSRG grant obligations.

9B. IF YOU DON'T RECEIVE THE FUNDS, WHAT COMPONENTS WILL BE DROPPED? WOULD THE PROJECT GET DONE WITHOUT CARA FUNDS? (Please provide a detailed explanation.)

Without CARA funding, we would need to significantly reduce the project scope or postpone implementation indefinitely.

Albany Civic Theater's primary focus must remain on critical building needs: structural integrity, safety compliance, and accessibility. The entrance improvements—including the crash doors, ADA-compliant foyer modifications, updated lighting, and security enhancements—directly address these essential requirements and would take priority over other improvements; however, the mural project would likely be set aside, as it—while valuable for community presence and economic development—is not essential to the building's core functionality.

Even completing the entrance project alone would strain our resources. As a fully volunteer-operated nonprofit with limited financial capacity, we would need to defer other necessary building maintenance and improvements to fund this work. Without CARA support, we would continue seeking alternative funding sources, but completing the full project as currently envisioned—or even the entrance improvements alone—would be difficult to achieve in a timely manner. This would delay safety and accessibility upgrades that our facility and community deserve.

10. WHERE ELSE HAVE YOU LOOKED FOR FUNDING?

We have not actively pursued external funding for either project prior to identifying the CARA opportunity. The entrance improvements and mural were both initiated in response to this funding opportunity. For the entrance project, we have explored potential funding sources through local economic development programs, historic preservation grants, and community improvement initiatives; no alternative funding sources have been identified that would cover the full scope of the desired entrance upgrades.

For the mural project, we have not yet pursued external funding sources. If CARA funding is not awarded, we would begin exploring additional grant programs, community partnerships, and local sponsorship opportunities to support the mural. Without CARA support, we would likely need to defer or reduce the scope of both projects due to our limited financial capacity as a fully volunteer-operated nonprofit.

11. CONSIDERING THE PROJECT GOALS OUTLINED IN THIS APPLICATION, PLEASE IDENTIFY THE VALUE YOUR PROJECT BRINGS TO CARA.

This project directly advances CARA's mission by transforming a high-visibility, underutilized asset—the west wall of Albany Civic Theater—into a vibrant public landmark that enhances downtown Albany's appeal and economic vitality.

With approximately 12,000 vehicles crossing the Ellsworth Bridge daily (93% passenger cars), the mural will serve as a dynamic “Welcome to Albany” gateway, drawing attention to the 1st Avenue retail corridor and encouraging visitors to linger, shop, and engage with local businesses. By beautifying a prominent streetscape and reinforcing the district's identity as a cultural destination, the project supports CARA's goals of stimulating public and private investment and creating a more inviting, active downtown.

Additionally, the entrance improvements—focused on safety, accessibility, and historic character—complement the mural by elevating the theater's physical presence and functionality, further anchoring it as a cornerstone of downtown revitalization.

**12. PLEASE OUTLINE ANY OTHER BENEFITS YOUR PROJECT PROVIDES.
(To Albany, and the area/neighborhood)**

Beyond beautifying the streetscape, this project actively combats urban blight by transforming a blank, underused wall into a dynamic public artwork that draws people in and encourages foot traffic along 1st Avenue. Well-designed public art has proven power to activate spaces—this mural will invite pedestrians to explore the retail corridor, benefiting nearby businesses and fostering a more lively, walkable downtown.

Strategically located at the gateway to Albany via the Ellsworth Bridge, the mural will become a recognizable landmark that strengthens the district's identity and encourages continued private investment in surrounding properties. By elevating the visual character and cultural appeal of the area, the project helps create a more attractive environment for residents, visitors, and business owners alike.

Importantly, the project will prioritize local artists and labor, directly supporting Albany's creative economy while leaving behind a lasting cultural asset that reflects our community's story. This investment in public art not only enhances daily life for residents but also signals to the broader region that downtown Albany is a place of creativity, vitality, and growth.

13. HAVE YOU OR THIS PROPERTY RECEIVED CARA FUNDING AT ANY POINT IN THE PAST?

No Yes If so, amount \$ 5000

FOR WHAT PROJECT(S): Rear facade and metal fire shutters

WHEN? 2011

14. ASSISTANCE REQUESTED

Total Estimated Project Costs:	\$ <u>144,000</u>
Your Total Contribution	\$ <u>36,000</u>
Total Amount Requested from CARA:	\$ <u>108,000</u>

Final payment will be based on actual costs not estimates. **Ten percent of CARA funds will be held back for final payment.**

15. BREAKDOWN OF USE OF CARA FUNDS

***CARA funds can only be used for permanent improvements to the building.** Please provide a breakout with specific details of how the CARA funds will be used in the project. If more space is needed, please attach a separate page.*

Item	Amount	Notes
Theater auditorium entry	42,000	Includes ornamental crown, doors, construction and engineering
West wall mural	102,000	New art piece painted along full west face of the building
TOTAL	144,000	Total should match total amount requested from CARA from line 14.

Metrics and Other Benefits

If you receive funding, you will be asked to tally the final figures on the project and certify their accuracy. Please use this space to estimate the impact of your project:

Number of Jobs Created: 0 Full-time 0 Part-Time

Certification

The Applicant understands and agrees to the following conditions:

1. Any physical improvements proposed must be approved by the Albany Revitalization Area Agency (ARA) and may require approval by the City of Albany Landmarks Advisory Commission or other entities. These entities may require certain changes or modifications before final approval and Commitment of Funds.
2. Any work begun before receipt of a Contract notice is ineligible for reimbursement.
3. Any work deviating from that detailed in the Contract must be preapproved in writing to be eligible for reimbursement.
4. While only proprietary information may be held in confidence outside of the public record, ARA will attempt to maintain all information provided in a confidential manner.
5. Originals of all materials prepared with ARA assistance belong to ARA and will be maintained in the public record.
6. Application must be completed in its entirety before being considered; if not, it will be returned for completion.
7. Staff is authorized to independently verify any and all information contained in this application.
8. ARA may withhold approval of this application until information satisfactory to ARA is provided.

The Applicant certifies that all information in this application and all information furnished in support of this application is given for the purpose of obtaining ARA assistance and is true and complete to the best of the Applicant's knowledge. Applicant further acknowledges the undersigned applicant(s) have read and understand CARA's privacy policy and have completed this form with accurate information.

Josh Mitchell

Doug Moxley

Applicant's Printed Name

Applicant's Printed Name

Applicant's Signature

Date

3/28/26

Applicant's Signature

Date

March 28, 2026

Return application/attachments to: City of Albany c/o Sophie Adams, Economic Development Manager: sophie.adams@albanyoregon.gov

- Picture Circa 1937



- Picture circa 1953
- Building purchased by Albany Civic Theater in 1968



Sat, Feb 28, 4:16 PM

Eileen Hinckle

to me

Hi Josh,

That's a wonderful spot for a mural, I'm glad you reached out to me!

For commercial mural jobs, my rate is \$20-\$60 per square foot plus the cost of paint and scissor lift rental. The rate per square foot is determined by the complexity of the design.

For a mural that included all of the elements you've described (large scale text, images related to the theater, and historic elements/landmarks), I would charge a rate at the upper end of the range due to the complexity of the design/amount of time it would take to paint.

I understand that the Albany civic theater is a non-profit organization and may not have the funding to cover the cost of such a mural. I'm open to working with limited budgets in the case of non-profits, and that limitation means the design needs to be simplified in order for me to be compensated fairly for my work.

If you have a rough idea of the amount of funding from the grant that would be allotted for the mural, I can give you an idea of what I could do for that amount of money.

I met with Douglas Hambley last summer to talk about this project, is he still working for the Albany Civic Theater?

Best,
Eileen

Wall approx.

20'h x 102'w

2040 SF

low end	→	mid	→	high end
\$49,800		\$81,600		\$122,400

assume \$50 / detailed

\$102,000 minimum

Eileen Hinckle

Eileen Hinckle has been painting murals since 2012. She immersed herself in the world of muralism during the seven years she spent living in South America. During this time, she participated in street art festivals, muralist brigades, artist collectives, and arts-based non-profits

After receiving a BA in Psychology from Northwestern University, Eileen completed a certificate program in Creative Illustration and Visual Communication Techniques at EINA University of Art and Design in Barcelona, Spain. She grew up in Oregon and her profound love for trees and nature is a central theme in her artwork. She currently lives in Boulder and is working towards an MFA in drawing and painting at CU Boulder

While her artwork spans many visual mediums, murals are at the heart of Eileen's artistic practice. She has painted over 80 murals across three different continents, including local and international mural festivals, educational murals, collaborations with other artists, community-based mural projects and activism.



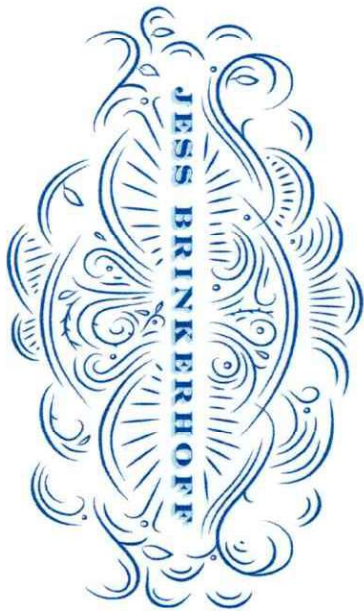

MURALS & DESIGN

MURAL ESTIMATE

MURAL ESTIMATE

Burggraf Building,
Albany Or.

“Welcome to Albany”
Exterior mural on stucco
Installed on freshly painted surface

W = 100'
H = 16'
1600SF

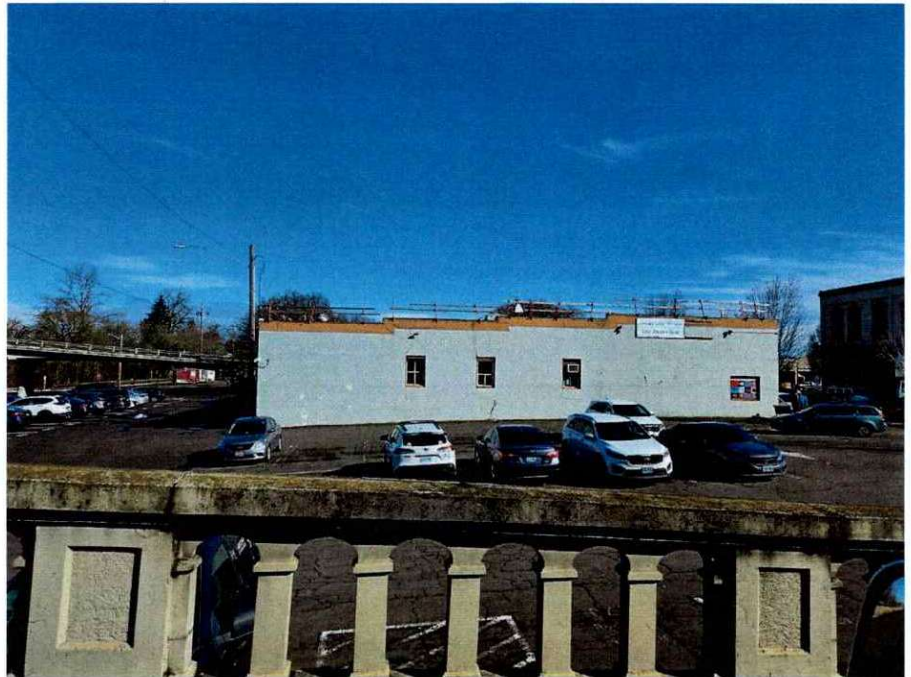

LESS COMPLEX RATE: \$50,000

MORE COMPLEX RATE: \$80,000

LESS COMPLEX=

LESS WALL COVERAGE, FEWER COLORS, LESS DETAIL, MORE SOLID SHAPES

MORE COMPLEX=

FULLER WALL COVERAGE, LARGER RANGE OF COLORS AND DETAIL, MORE RENDERED IMAGERY

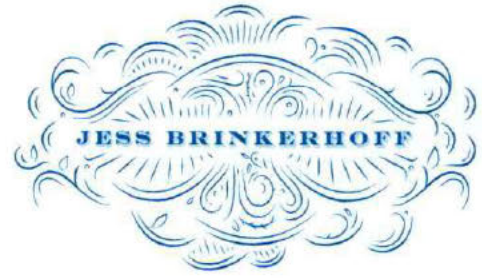

MURALS & DESIGN

MURAL RATES

**JESSILYN
BRINKERHOFF**

BRINK CREATIVE
LLC.

SEE THE WORK AT
JBRINKERHOFF.COM

A CUSTOM WALL MURAL INCLUDES:

+ Concept

Derived from a conversation with the client on the artwork theme, I will create a rendered design for the artwork and present to client.

+ Revisions

1 round of revisions included, additional rounds are an added fee.

+ Materials

Insurance, ladder, paint, brushes, dropcloths.

+ Application

Installation of approved artwork in your space. Duration of installation varies depending on design.

+ ADD-ON FOR ADDITIONAL PURCHASE

Digital file of artwork design for for use in marketing, packaging, branding

**+ ADD-ON ADDITIONAL WALL MURAL OR PROJECT
\$250 OFF**

COST:

BASE RATE: INTERIOR MURAL

\$50/SQ. FT. USD

Rate for interior, ground level installation on smooth surfaces, medium detail

BASE RATE: MURAL CLOTH

\$55/SQ. FT. USD

Rate for interior, ground level installation on smooth surfaces, medium detail

BASE RATE: EXTERIOR MURAL

\$60/SQ. FT. USD

Rate for exterior installation on smooth surfaces, medium detail

CUSTOM MURAL MINIMUM \$5,000

\$102,000



JESSILYN & LUCAS BRINKERHOFF | Brink Creative LLC
PUBLIC ART & NATURAL HISTORY ARTIST TEAM

EXPERIENCE SUMMARY:

Using murals to educate and bring people together, sibling team Jessilyn and Lucas Brinkerhoff operate as Brink Creative and have over fifteen years of creating 90+ murals and public art projects from natural and social history research.

EDUCATION

Jessilyn Brinkerhoff:

University of Oregon, Eugene, Oregon, 2011

Bachelor of Arts in Fine Art & Design/Material Studies, Small Business, Biology

Lucas Brinkerhoff:

University of Oregon, Eugene, OR, 2014

Bachelor of Science in Geological Sciences, Botany, Calculus

SELECT EXPERIENCE

LCC Health Professions Building Mural Series, Eugene, Oregon, 2025

Design weaves natural networks and metaphors for growth, expansion and the visual overlap between humans and the larger natural community. Rivers, weather, roots, wings and the human fingerprint represent pathways of movement, information and communication at this learning facility. Budget: \$110k

Albina Library Mural, Portland, Oregon, 2025

Design in Progress. Mural features joyfulness & telling future stories of the diverse Albina neighborhood for the renovated Budget: \$12k

OHSU In-Patient Addition Mural Series, Portland, Oregon, 2025

Series of 12 Interior murals printed on vinyl featuring Northwest ecosystems and healing plants. Imagery is uplifting and gentle to inspire patients at the in-patient oncology department. Budget: \$18k

The Standard Mural Series, Eugene, Oregon, Summer 2024

Exterior murals drawing inspiration from the basalt columns at Skinner's Butte. Featuring trillium, oxalis, sword fern, beaked moss and many other native species. Budget: \$75k

City of McMinnville Art Alley Mural, McMinnville, Oregon, 2024

Nouveau inspired mural depicting creativity, music and native plants for McMinnville's Art Alley. Budget: \$5k

Lane County Youth Services Mural, Eugene, Oregon 2024

Series of 10 interior murals for the Youth Resource Center at the Serbu Campus. Inspirational imagery depicts transformation, growth and freedom in flowing colors. Budget: \$20k

Multnomah County Public Library Mural, Portland, Oregon, 2023

"Cherish". This composition on birch panels features cherished species from Northwest ecosystems. Depicted are a polyphemus moth, cedars, white oak, Mt. Hood, and views of the landscapes they reside in. Budget: \$12k

Facebook Mural, Prineville Meta Data Center, Oregon, 2023

Interior Mural commissioned by Meta to feature Oregon landscapes and plants. Created field studies of these species in partnership with local biologist and native plant society to inform the mural. Budget: \$10k

Architectural Fabrication of Spiral Staircase, Poolside Trellises, and Railing California, 2023

Lead Fabricator with Functional Steel Objects (FSO) overseeing onsite operations, technical revisions, and primary fabrication/installation of wrought iron Floating Spiral Staircase, Trellises and Railings. Budget \$190K

Welcome to Tacoma Mural, Tacoma, Washington, 2022

Portland Living Building Natural History Murals, Portland, Oregon, 2021

Work features three NW ecosystems and were created from field research at coastal, alpine and forest sites.
<https://www.pae-engineers.com/projects/pae-portland-living-building> Budget: \$27k

Native Botanical Mural, Gordon Hotel and 5th St. Market, Eugene, Oregon, 2021

Mural commissioned by Obie Companies 5th St. Market. Interior and exterior works for Hotel feature native plants
 Prairie Fire (Indian Paintbrush) and Mule's Ear Budget: \$5k

US Women's Nation Team: Women's Roses Soccer Mural, Portland, Or. 2019

Commissioned by USWNT for a campaign of women muralists painting women soccer players before the World Cup in France. Painted Roses and Portland Thorns players Tobin Heath and Lindsey Horan. Budget: \$5k

Prairie Line Trail History Mural Commission, City of Tacoma, Washington, 2017

Commission with historical society and native Puyallup tribe. Research driven design featuring local stories in Tacoma's history using source documents and images. Budget \$55k

City of Medford Natural History Mural Series, Medford, OR 2015

The Wildlife Calendar Walk mural series features one native species for each month in Southern Oregon. Artwork design and install of six 30 foot concrete pillars under Interstate-5 in Hawthorne Park. Budget: \$45k

City of Grants Pass, Copper Salmon Sculpture 2018-2019

Design, Fabrication, and Installation of two 7ft Copper Salmon Sculptures, budget 15k

SKILLS**Jessilyn Brinkerhoff:**

Large Format Fine Art Drawing, Painting, Illustration
 Latex Mural Installation for Exterior/Interior, Pillars, Streets
 10 Years of Community Engagement Workshops and Community Painting Sessions
 Verbal and Visual Communication, Art Direction
 Design for 2-D sculpture and fabricator management
 Digital Artwork Production for Vinyl/Digital Large Format Printing
 Project Management

Lucas Brinkerhoff:

Sculptor, builder, and architectural fabricator specializing in large-scale public art and custom installations
 Owner/operation of art specific prototype studio involving foundry and various CNC machines

Fine Art Mediums:

Sculpture - Copper, Bronze, Steel, Aluminum, Wood, Ceramic, Composite, Clay, Rubber
 Painting - Acrylic, Enamel, Watercolor, Latex, urethane, Epoxy
 Illustration - Ink, Pastel, Charcoal
 Lighting Design - custom sculptural and Suspended installations, LED wiring/programming

Construction/Fabrication:

Metal - Art foundry casting in copper/bronze, ARC, MIG, TIG Welding,
 CNC - Plasma and CO2 laser cutting, FDM and Resin 3d printing, metal and wood machining
 Wood - Art Installations, Finish carpentry, Traditional, Log, and Timber-frame Construction
 Masonry - Foundations, Slabs, and Pedestals of brick, block, tile and stone.
 Industrial - vacuum casting, thermoforming, sign making
 Digital - 3D modelling, rendering, digital design, 3D scanning, photography

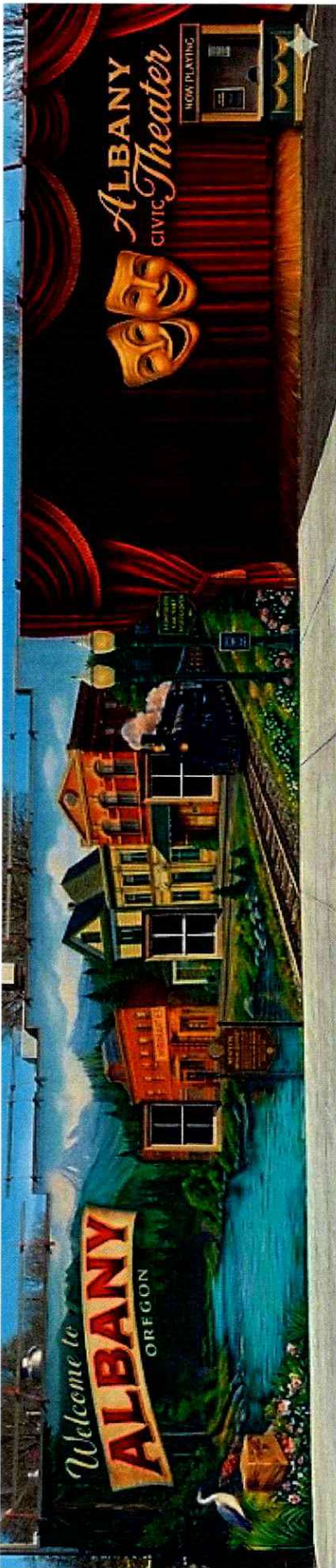



Board Meeting Minutes

Date: March 1st, 2026

Time: 5:30 pm

Location: Albany Civic Theater Lobby

Last Meeting: February 8th, 2026

Next Meeting: April 12th, 2026

Board members present: Jillian Alden, Doug Moxley, Douglas Hambley, Kathie O'Brien, Frankie Caswell, Josh Mitchell, Diane Slamp (joined late)

Members present: Krisi Leffler, Dean Keeling

Agenda Item	Lead
Call to Order	Chair; Doug Moxley, President
	5:31pm.
Board Announcements	Chair; Doug Moxley, President
	None
Board Member Adjustments to the Agenda	Chair; Doug Moxley, President
	None
Approval of Previous Board Meeting Minutes January 11, 2026 Regular Meeting February 8th, 2026 Regular Meeting	Chair; Doug Moxley, President
Kathie O'Brien motioned to approve the January and February meeting minutes. Frankie Caswell seconds. Motion carries.	
Financial Report Show Statements February Financial Report	Kathie O'Brien, Treasurer Luke Chicquaye, Assistant Treasurer
Kathie issued a congratulations to Jekyll and Hyde for their ticketing and income success. Kathie shared that Jekyll and Hyde earned the highest non-musical net income in the past 2 ½ years.	
Show Reports	
<i>Alice in Wonderland</i> Optional - Progress Report	Conner Riley
Krisi reported that things for the show have been going really well despite some road bumps, and the cast and crew are adjusting as needed. Krisi reported that they are feeling pretty	

confident going into tech week that the show will be ready to open soon.	
<i>The Pirates of Penzance</i> Optional - Progress Report	Christi Sears
Frankie reported (as their liaison) that everything seems to be going well.	
<i>Greater Tuna</i> Optional - Unusual or special requests	Lance Duddleston
No one to report.	
<i>Midsummer Night's Dream</i> Optional - Unusual or special requests	Arlee Olson
No one to report.	
Old Business	
Costume Project Update	Conner Riley, Costume Manager
No one present to report.	
Bylaws Revision Update	Doug Moxley, President
<p>Doug announced that after this evening he will be emailing the board a copy of the existing bylaws and the proposed new set of bylaws. Doug clarified that because some of the language needed clarification, the update will include adjustment to membership rights (he thinks for the better, as it will be clearer to understand) and will therefore need membership approval. Doug stated that he hopes to provide the bylaws at the April Membership Meeting with the vote occurring at the July Membership Meeting so that members have ample time to consider the proposed updates, ask questions, and make suggestions before voting and approving them.</p>	
NeonOne CRM Update	Doug Moxley, President Jillian Alden, Secretary
Doug and Jillian stated that there haven't been any significant updates to the establishment of Neon CRM at this time.	
Proposed Policy Change Policy 5030 Giving Complimentary (Comp) Tickets, Passes, Vouchers, or Gift Certificates	Doug Moxley, President
<p>Doug discussed the proposed changes to the policy, highlighting that board members (beginning with the 2026/2027 board) will receive season passes for the season they are serving, and that managers receive two individual comp tickets per season as the major changes to the policy.</p> <p>Kathie O'Brien moved to approve the changes as presented to policy 5030. Jillian Alden seconds. Discussion. Vote. Motion carries.</p>	
New Business	

<p>Charge to the 2026 Nominating Committee</p>	<p>Doug Moxley, President</p>
<p>Kathie O'Brien moved to adopt the charge to the nominating committee with the adjust that the chair is to be determined. Diane Slamp seconds. Vote. Motion carries.</p>	
<p>Charge to the Design Team Committee</p>	<p>Josh Mitchell, Facilities Coordinator</p>
<p>Doug reviewed the charge to the design team committee. Dean Keeling asked for clarification on the committee's responsibilities in decision making and proposals to the board on a timeline. Discussion. Douglas Hambley moved to adopt the charge to the design team committee as presented in the agenda. Frankie Caswell seconds. Vote. Motion carries.</p>	
<p>Design Team Committee Update</p>	<p>Dean Keeling</p>
<p>Josh Mitchell presented that the overall feeling of the committee is looking into how to increase the theater storage. Josh shared the committee seems to generally favor adding a mezzanine to the Next Stage building to add additional space, with multiple options for specific locations. Josh added that a big focus of the committee is remodelling bathrooms to be ADA compliant and looking into two unisex bathrooms in the Next Stage space. Josh continued to discuss the idea of remodelling a corridor that connects the current ACT lobby space to the new building space in some way. Dean Keeling proposed that the committee would like to move costumes to the future mezzanine in the new space because the space will be considerably larger, and would like to turn the current costume loft into props and furniture storage. Dean discussed that they want to have a work party in April to move the props into the current costume loft to begin working on the pass-through corridor between the buildings. Dean discussed the CARA grant (Central Albany Revitalization Area Grant) and that the committee has a few projects they would like board approval to put in the grant application. Dean described purchasing a "fancy" historical looking awning for the front of the auditorium, more appropriate and updated lighting for the awning, and new crash doors with expanded space to allow future space for the future tech-booth move from upstairs to downstairs. Dean says that the second proposal for use of CARA funds would be to commission mural on the wall facing the Ellsworth Street bridge. Kathie reminded Dean to consider the ACT match for this grant and that it cannot overlap with the funds/match of the OSMR grant. Frankie Caswell moves to approve authority for the design team committee to apply for the CARA grant to fund the projects as presented above. Jillian Alden seconds. Vote. Motion carries.</p>	
<p>Street Address Consolidation</p>	<p>Doug Moxley, President</p>
<p>Doug discussed that ACT now currently owns four addresses and multiple utility meters. Doug discussed that he met with some folx from the City of Albany to discuss consolidating our addresses, and that it is not a lengthy or difficult process but it does come with a fee. Doug reported that he will be updating the board in the future as he gains more information about the process to get approval from the board to do this. Discussion.</p>	
<p>Board Member Reports</p>	

River City Design & Build

1305 Old Salem Rd NE

Millersburg, OR 97321

CCB# 246630, C#2069



ESTIMATE # 2026-111

ADDRESS

Albany Civic Theater

111 W 1st Av

Albany, OR 97321

ACTIVITY

AMOUNT

00 Description (Phase 1)

01 Design

\$ 1,125.00

Building design, drawings, plans

02 SDCs & Permits

\$ 1,800.00

Permits, Landmarks committee

03 Demo

\$ 2,400.00

Removal of work-site debris, existing house doors

04 Excavation

\$ -

05 Concrete

\$ 800.00

New footings (if req'd)

06 Foundation

\$ -

07 Underfloor

\$ -

08 Floor Frame

\$ -

09 Wall Frame

\$ 2,730.00

New Entry framing, header support, enclose old shadow boxes

10 Roof

\$ -

11 Trusses

\$ -

12 Siding

\$ 3,960.00

Stucco to match existing

13 Door & Trim

\$ 4,275.00

Historic design custom house doors (match new facade)

14 Windows & Trim

\$ -

15 Plumbing		\$ 2,700.00
	<i>Relocate and plumb fire supression heads</i>	
16 HVAC		\$ -
17 Electrical & Lighting		\$ 5,400.00
	<i>New electrical lighting, exterior, foyer (ADA optional), prep marquee</i>	
18 Insulation		\$ 540.00
	<i>Exterior walls & attic as needed</i>	
19 Interior Walls		\$ 2,200.00
	<i>Hang, mud, tape, texture</i>	
20 Cabinets & Vanities		\$ -
21 Floor Coverings		\$ 2,200.00
	<i>\$3.50/SF material allowance upstairs (LVP, carpet)</i>	
22 Paint		\$ 1,250.00
	<i>Prime, interior to match existing (Paint provided)</i>	
23 Landscaping & Paving		\$ -
24 Appliances		\$ -
25 Countertops		\$ -
26 Garage Door(s)		\$ -
27 Well		\$ -
28 Septic		\$ -
29 Gutters		\$ -
30 SITE SPECIFIC		\$ 2,510.40
	<i>New ornamental crown/crest to ACT marquee, medalion(s)</i>	
31 CONTINGENCY		\$ 3,025.50
	<i>Misc 10%</i>	
32 PROJECT MANAGEMENT		\$ 5,083.56
	<i>15% fee</i>	
SUBTOTAL (Phase 1)		\$ 41,999.46
SITE SPECIFIC (Phase 2)		\$ 102,000.00
	<i>New mural commissioned for West facing wall (adjacent to parking)</i>	
SUBTOTAL (Phase 2)		\$ 102,000.00
TOTAL PROJECT		\$ 143,999.46



Project Evaluation Grid: 111 W 1st Avenue

Request: 108,000

Item	Description	Staff Analysis/Comments	
<i>Overall Goals</i>			
A)	<p>CARA Goal & Objectives: The purpose of this CARA Plan is to eliminate blighting influences found in the CARA, to implement goals and objectives of the City of Albany Comprehensive Plan, and to implement development strategies and objectives for the CARA. The goal and objectives for the CARA have been defined as follows:</p> <p>CARA Goal: To revitalize the Central Albany Revitalization Area by implementing the Town Center Plan developed through the Central Albany Land Use & Transportation Study (CALUTS) using a citizen-driven process.</p>	<p>Does the project further the Town Center Plan?</p> <p>Which of CARA's objectives does the project meet?</p> <p>CARA Key Objectives:</p> <ul style="list-style-type: none"> ◆ Attract new private investment to the area. ◆ Retain and enhance the value of existing private investment and public investment in the area. <p>CARA Additional Objectives:</p> <ul style="list-style-type: none"> ◆ Provide a safe and convenient transportation network that encourages pedestrian & bicycle access to and within the town center. ◆ Preserve the Historic Districts, historic resources and existing housing in the area. ◆ Create a readily identifiable core that is unique and vibrant with a mixture of entertainment, housing, specialty shops, offices, and other commercial uses. ◆ Increase residential density in the area. ◆ Encourage the development of new forms of housing and home ownership. ◆ Enhance and protect the community and environmental values of waterway corridors in the area. ◆ Provide an enriching environment and livable neighborhoods. 	<p>Yes.</p> <p>This project meets CARA's two key objectives as listed.</p> <p>Addition objectives met:</p> <p>Historic preservation Readily identifiable core Enriching environment</p>
B)	CARA Planned Projects	Which project category and activity in the UR Plan does this project fulfill? (See CARA Project Activities document, or Table 2 of the UR Plan and Report.)	Commercial Building Rehabilitation
C)	Development Pattern (Highest and Best Use)	Does it achieve desired land use (e.g., mixed-use, higher density) and/or transportation objectives (e.g., Esplanade, pedestrian-friendly areas)? Is the proposed project desired in this location and the highest and best use of the property?	Zone: Historic Downtown (HD) Yes; highest and best use of the property
D)	Blight	Would it remedy a severely blighted building? How? Does the project utilize a vacant space?	Indirectly supports activation of expanded ACT property that has been vacant for years.

E)	Preservation	Would it rehabilitate or sensitively redevelop a historic property?	Yes.
F)	Vitality/People Attractor	Does the general public benefit (i.e. restaurant, carousel, something they can go to; does the project enhance the public's experience of the space; is it a business we are seeking)?	Yes.
G)	Retail Hotspot (First Avenue between Lyon and Calapooia)	Is the project located in the Retail Hotspot? If so, will the first floor use be active retail, as recommended in the Retail Refinement Plan?	No.
H)	Sustainable Building	Will the building be built using sustainable practices including LEED or others?	Not addressed in application.
I)	Residential	Is there a residential component? How many units?	No.
<i>Economic Development</i>			
J)	Bring new business to Albany	Will a new business open or come to Albany as a part of this project?	No.
K)	Job Creation	Will the project create additional jobs? How many, what types and what salary level?	No.
L)	Local Labor and Materials	Has applicant specifically called out a commitment to use a certain percent or amount of local labor and/or materials?	Yes, commitment to use local contractors for this project.
<i>Financial</i>			
M)	Ratio	Proposed public funds Private funds % of CARA Investment	Applicant requesting 75% of total project costs
N)	Financial Impacts	What are the financial risks and/or financial benefits to CARA?	Reimbursement based-grant; low financial risk. Benefits through increased value.
O)	Gap	What is the "Gap" or need of the developer?	\$108,000
P)	Private Risk	What is the risk for the developer? What is their skin in the game?	\$36,000 for this project phase.
Q)	CARA/City funds	Has the project received other CARA/City funding in the past?	Yes, past CARA and Collaborative Tourism Promotion funds.
R)	Tax Increment ROI	Is the ROI on this project less than 5 years, less than 7 years?	ROI will be achieved through increased property value.



CARA GRANT APPLICATION

1. APPLICANT

Name: Janel & Matt Bennett

Mailing Address: [REDACTED]

Zip Code: [REDACTED]

Title: Owners Phone Number: [REDACTED]

E-mail Address: [REDACTED]

2. BUSINESS/BUILDING INFORMATION

Legal Business Name: Sybaris Inc.

Number of Years in Operation: 25

Legal Form: Sole Proprietorship Partnership Corporation S-Corp LLC
 Profit Nonprofit

EIN: [REDACTED]

In which state are the incorporation and/or organization documents filed? Oregon

Have you ever filed for bankruptcy? Yes No

Project Address (if different than mailing address): 133 5th Ave SE

Property Tax Account Number: 11S03W07BA00800

Is the building a historic contributing resource? Yes No

If so, is it on the historic property-tax freeze? Yes No

3. OWNER OF PROPERTY (if not applicant)

Name in which title is held: Monteith Square LLC

Contact Name: Matthew Bennett, Manager

Mailing Address: [REDACTED]

Zip Code: [REDACTED]

Phone Number: [REDACTED]

4. AUTHORIZATION TO UNDERTAKE WORK:

If the applicant is not the owner of the property, provide written evidence that the owner authorizes this work to be undertaken. (Typically this is in the form of a lease or other written permission.)

5. DESCRIPTION OF PROJECT *Please give a comprehensive description of project.*

This application is for Phase 2 of our project to rehabilitate the site of the Oregon Electric Railroad (OER) Depot. Phase 1 will be complete in time to relocate Sybaris Bistro to this new location in April 2026. Phase 2 is unscheduled, unfunded future work. For Phase 2, we intend to renovate the 1,722 SF addition along Lyon Street built in 2003. It was originally a party room and dining room overflow for the former pizza parlor. It has now been separated from the Depot building. We would like to remodel the interior for use as event and conference space, upgrading access front and rear to improve the aesthetic of the location as a welcoming feature to historic downtown. To expand the event opportunities, we would install a covering over a 2,300 sf patio constructed in Phase 1 and construct a new outdoor fireplace.

6. TIMELINE FOR COMPLETION OF PROJECT: July 2026 - April 2027

7. PROJECT COSTS

ESTIMATED COST OF PROJECT: \$ 562,359

ESTIMATED VALUE OF PROJECT UPON COMPLETION: \$ Unknown

Basis for valuation and value upon completion: Pyburn & Sons

SOURCES FOR PROJECT:

Owner/Company Contribution \$ 140,589

Bank (estimated) \$

Other private funds (please specify) \$

Other governmental (please specify) \$

CARA (proposed) \$ 421,770

TOTAL SOURCES \$ 562,359

Is your funding for these: available today applied for unknown at this time

USES FOR PROJECT:

Land and/or Building Acquisition \$

Soft Costs (architectural, engineering, financing, and legal fees, and other pre- and post-construction expenses.) * \$ 90,306

Construction Costs * \$ 472,053

Tenant Improvements \$

Machinery/Equipment/Installation Costs \$

Working Capital \$

Other (please specify) \$

TOTAL USES \$ 562,359

*Please provide a detail of Soft Costs and of Construction Costs (Please attach).

8. PREPARATION OF COST ESTIMATES

Who prepared your cost estimates? Pyburn & Sons

(If applicant prepared their own estimate, verification may be required. **Please attach minimum of two bids, preferably three.**)

Mailing Address: PO Box 986 Albany, Oregon 97321

Phone Number: 541.926.0616 E-mail: mat@pyburnandsons.com

9A. EXPLAIN WHY CARA FUNDING IS NECESSARY TO INSURE PROJECT COMPLETION.

(Please provide a description of the financial gap requiring CARA assistance.)

First and foremost, Sybaris Bistro is a well-known restaurant of 25 years. The restaurant will re-open at the new location in April 2026 in the fully restored OER Depot. Lesser known but highly significant to the Albany community is the role we play as a venue for special occasions. We host fundraisers for non-profit agencies, often donating food and staff on days we are closed (Sunday, Monday). We host other special occasions for businesses and families alike, celebrating promotions, retirements, weddings, and birthdays, as well as trying to attract new business to Albany. We could continue this full slate of restaurant and hospitality activities within the restored OER Depot, but the site offers a tremendous opportunity to do more by expanding event opportunities into the 2003 addition and improving the new patio. CARA funding has come at an opportune time for our project budget. Every cent is going toward re-opening the restaurant in the restored OER Depot for Phase 1. No funding has been allocated for hospitality improvements in Phase 2. The CARA grant program is the impetus to move ahead with Phase 2 and complete the entire project.

9B. IF YOU DON'T RECEIVE THE FUNDS, WHAT COMPONENTS WILL BE DROPPED? WOULD THE PROJECT GET DONE WITHOUT CARA FUNDS? (Please provide a detailed explanation.)

Phase 2 work would wait until subsequent funding is found sometime in the future.

10. WHERE ELSE HAVE YOU LOOKED FOR FUNDING?

We made our debut request for CARA funding in 2022 when our estimated costs were almost two million dollars to restore the OER Depot. We asked CARA to contribute 28% of project cost, supplementing private and commercial funding plus an Oregon Heritage grant. No CARA funds were granted for Phase 1 but we are hoping to add the City of Albany as a proud partner for Phase 2. We maxed out private and commercial lending to complete renovation of the OER Depot in Phase 1 so Sybaris Bistro could relocate and open by April 2026. A CARA grant would energize our Phase 2 effort.

11. CONSIDERING THE PROJECT GOALS OUTLINED IN THIS APPLICATION, PLEASE IDENTIFY THE VALUE YOUR PROJECT BRINGS TO CARA.

The OER Depot is a unique local landmark situated on a highly visible corridor and gateway into Albany's historic downtown. The landmark is in the Hackleman National Register Historic district. The Depot had fallen into disrepair over the years, and since Ciddici's Pizza closed in 2020, the abandoned property had become blighted. The Depot will be restored with Phase 1 but the interior of the 2003 addition has fallen into a dilapidated condition. A partnership grant from CARA will stabilize ongoing use for many years to come. This undertaking significantly contributes to the City's efforts to promote historic preservation, tourism, downtown revitalization, and economic development. Because this project shares these values with the City, it is a prime candidate for a private-public partnership to fund the unmet financial need to complete the project. It would also incentivize private investment in commercial properties and historic residences in the area including the Hackleman Historic District.

12. PLEASE OUTLINE ANY OTHER BENEFITS YOUR PROJECT PROVIDES.

(To Albany, and the area/neighborhood)

It cannot be understated the role Sybaris Bistro plays in hosting fundraising events for non-profit organizations and contributing to the hospitality needs of special occasions, all in service to the Albany community. The OER Depot site will be uplifting the often-neglected Hackleman District much like the First Street location did for a neglected portion of the Montieth District 25 years ago. The building will serve as a gateway feature to historic downtown Albany. The project fills in a gap of the commercial fabric of the Lyon Street corridor. It adds vitality and attracts people to historic downtown Albany. We have used local labor and materials in this project. After Sybaris Bistro vacates 442 1st Avenue W, there will also be the opportunity for another restaurant in that space.

13. HAVE YOU OR THIS PROPERTY RECEIVED CARA FUNDING AT ANY POINT IN THE PAST?

No Yes If so, amount \$ _____

FOR WHAT PROJECT(S): \$113 for awning awarded but not used

WHEN? 2010

14. ASSISTANCE REQUESTED

Total Estimated Project Costs:	\$ <u>562,359</u>
Your Total Contribution	\$ <u>140,589</u>
Total Amount Requested from CARA:	\$ <u>421,770</u>

Final payment will be based on actual costs not estimates. **Ten percent of CARA funds will be held back for final payment.**

15. BREAKDOWN OF USE OF CARA FUNDS

***CARA funds can only be used for permanent improvements to the building.** Please provide a breakout with specific details of how the CARA funds will be used in the project. If more space is needed, please attach a separate page.*

Item	Amount	Notes
Conference room improvements	148,541	see attached budget
Outdoor patio improvements	261,940	see attached budget
contingency	11,289	see attached budget
TOTAL	421,770	Total should match total amount requested from CARA from line 14.

Metrics and Other Benefits

If you receive funding, you will be asked to tally the final figures on the project and certify their accuracy. Please use this space to estimate the impact of your project:

Number of Jobs Created: _____ Full-time 3 Part-Time

The completion of phase 2 would allow for 3 part time employees that Sybaris would add at the completion of the project.

Certification

The Applicant understands and agrees to the following conditions:

1. Any physical improvements proposed must be approved by the Albany Revitalization Area Agency (ARA) and may require approval by the City of Albany Landmarks Advisory Commission or other entities. These entities may require certain changes or modifications before final approval and Commitment of Funds.
2. Any work begun before receipt of a Contract notice is ineligible for reimbursement.
3. Any work deviating from that detailed in the Contract must be preapproved in writing to be eligible for reimbursement.
4. While only proprietary information may be held in confidence outside of the public record, ARA will attempt to maintain all information provided in a confidential manner.
5. Originals of all materials prepared with ARA assistance belong to ARA and will be maintained in the public record.
6. Application must be completed in its entirety before being considered; if not, it will be returned for completion.
7. Staff is authorized to independently verify any and all information contained in this application.
8. ARA may withhold approval of this application until information satisfactory to ARA is provided.

The Applicant certifies that all information in this application and all information furnished in support of this application is given for the purpose of obtaining ARA assistance and is true and complete to the best of the Applicant's knowledge. Applicant further acknowledges the undersigned applicant(s) have read and understand CARA's privacy policy and have completed this form with accurate information.

Matthew Bennett

Janel Bennett

Applicant's Printed Name

Applicant's Printed Name

Applicant's Signature

Date

3/24/2020

Applicant's Signature

Date

3/24/2020

Return application/attachments to: City of Albany c/o Sophie Adams, Economic Development Manager: sophie.adams@albanyoregon.gov



COMMERCIAL • RESIDENTIAL

QUALITY BUILDING *and* REMODELING

PO Box 986, Albany Oregon 97321

CCB# 44599

March 20, 2026

Sybaris Conference Room and Patio Improvement Project Budget

Conference Room Improvements, Accessible Route & Sign Repair:

Repair and upgrade existing storage area to convert it to a new conference and meeting space. Work includes new interior finishes, electrical and mechanical system along with restroom improvements. Provide a new accessible route from new meeting space to back patio with ADA ramp. Refurbish existing sign base and frame. Provide new street side cable railing system.

Construction Budget: \$174,001

Outdoor Patio Improvements:

Provide and install a new all-weather patio cover system with a retractable fabric awning. Provide a new outdoor fire-place at the patio area.

Construction Budget: \$236,480

Total Construction Budget:	\$410,481
Project Contingency:	\$ 61,572
Soft Costs and Permitting:	\$ 90,306
<u>Total Project Cost:</u>	<u>\$562,359</u>

Sybaris New Location - Improvements / Patio Build Out 3-9-2026

Conference Room Improvements

Item #	Description	QTY	Units	\$/Unit	Budget
1	New Interior Door	4			\$ 6,200
2	New Exterior Door	1			\$ 6,800
3	Restroom Refurbish to match	1			\$ 41,552
4	New Floor	1367	SF	15	\$ 20,505
5	New Ceiling	1367	SF	10.8	\$ 14,764
6	New Painting				\$ 7,680
7	GWB Patching				\$ 3,400
8	Electrical				\$ 24,000
9	HVAC				\$ 18,000
10	Trim				\$ 5,640

SUBTOTAL \$ 148,541

Accessible Route Improvements

Item #	Description	QTY	Units	\$/Unit	Budget
1	Pony Walls				\$ 3,600
2	Concrete Ramp				\$ 4,800
3	Mechanical Pads				\$ 500
4	Grading				\$ 2,670
5	Exterior Historic Railing System				\$ 8,400

SUBTOTAL \$ 19,970

Existing Sign Refurbish

Item #	Description	QTY	Units	\$/Unit	Budget
1	Clean & Repaint Pole/Frame				\$ 1,440
2	New Electrical				\$ 650
3	New Sign Graphics				\$ 3,400

SUBTOTAL \$ 5,490

Patio Cover System

Item #	Description	QTY	Units	\$/Unit	Budget
1	Powder Coated Steel Framing System				\$ 55,880
2	Concrete Anchors / Foundation				\$ 18,500
3	Electrical/Lights				\$ 9,500
4	Gutter Connections				\$ 5,200
5	New Awning System - Owner Allowance	1680	SF	40	\$ 67,200

\$ 156,280

Outdoor Fireplace

Item #	Description	QTY	Units	\$/Unit	Budget
1	Concrete Foundation				\$ 7,500
2	Shot Crete Structure				\$ -
3	Finishes				\$ 20,000
4	Chimney Venting				\$ 40,000
5	Electrical				\$ -
6	Natural Gas				\$ 5,200
7	Mechanism				\$ 7,500

SUBTOTAL \$ 80,200

Total Construction Budget		\$ 410,481
Contingency	15%	\$ 61,572
Soft Costs and Permitting	22%	\$ 90,306
Total Projected Project Cost		\$ 562,359



March 9, 2026

Sybaris Conference Room and Patio Improvement Project Budget

Conference Room Improvements, Accessible Route & Sign Repair:

Repair and upgrade existing storage area to convert it to a new conference and meeting space. Work includes new interior finishes, electrical and mechanical system along with restroom improvements. Provide a new accessible route from new meeting space to back patio with ADA ramp. Refurbish existing sign base and frame. Provide new street side cable railing system.

Construction Budget: \$129,400

Outdoor Patio Improvements:

Provide and install a new all-weather patio cover system with a retractable fabric awning. Provide a new outdoor fire-place at the patio area.

Construction Budget: \$267,840

Total Construction Budget:	\$389,080
Project Contingency:	\$ 59,532
Soft Costs and Permitting:	\$ 119,064

Total Project Cost: \$575,476

Cordially,



Ryan McAlister
President, Gerding Builders



Sybaris New Location - Improvements / Patio Build Out 3-9-2026

Conference Room Improvements

Item #	Description	QTY	Units	\$/Unit	Budget
1	New Interior Door	1	EA	2800	\$ 2,800
2	New Exterior Door	1	EA	3600	\$ 3,600
3	Restroom Refurbish to match	2	EA	15500	\$ 31,000
4	New Floor	1400	SF	6	\$ 8,400
5	New Ceiling	1400	SF	5	\$ 7,000
6	New Painting	1400	SF	4	\$ 5,600
7	GWB Patching	1400	SF	3	\$ 4,200
8	Electrical	1400	SF	10	\$ 14,000
9	HVAC	1400	SF	14	\$ 19,600
10	Trim	1400	SF	3	\$ 4,200

SUBTOTAL \$ 100,400

Accessible Route Improvements

Item #	Description	QTY	Units	\$/Unit	Budget
1	Pony Walls	60	LF	80	\$ 4,800
2	Concrete Ramp	280	SF	15	\$ 4,200
3	Mechanical Pads	2	EA	650	\$ 1,300
4	Grading	300	SF	4	\$ 1,200
5	Exterior Historic Railing System	60	LF	140	\$ 8,400

SUBTOTAL \$ 19,900

Existing Sign Refurbish

Item #	Description	QTY	Units	\$/Unit	Budget
1	Clean & Repaint Pole/Frame	1	EA	1600	\$ 1,600
2	New Electrical	1	EA	2500	\$ 2,500
3	New Sign Graphics	1	EA	5000	\$ 5,000

SUBTOTAL \$ 9,100

Patio Cover System

Item #	Description	QTY	Units	\$/Unit	Budget
1	Powder Coated Steel Framing System	1680	SF	38	\$ 63,840
2	Concrete Anchors / Foundation	1680	SF	2	\$ 3,360
3	Electrical/Lights	1680	SF	3	\$ 5,040
4	Gutter Connections	3	EA	900	\$ 2,700
5	New Awning System - Owner Allowance	1680	SF	40	\$ 67,200

\$ 142,140

Outdoor Fireplace

Item #	Description	QTY	Units	\$/Unit	Budget
1	Concrete Foundation	112	SF	85	\$ 9,520
2	Shot Crete Structure	322	SF	220	\$ 70,840
3	Finishes	322	SF	40	\$ 12,880
4	Chimney Venting	1	EA	11000	\$ 11,000
5	Electrical	1	EA	2500	\$ 2,500
6	Natural Gas	1	EA	3600	\$ 3,600
7	Mechanism	1	EA	15000	\$ 15,000

SUBTOTAL \$ 125,340

Total Construction Budget \$ 396,880

Contingency 15% \$ 59,532

Soft Costs and Permitting 30% \$ 119,064

Total Projected Project Cost \$ 575,476



Project Evaluation Grid: 133 5th Avenue SE

Request: \$421,770

	Item	Description	Staff Analysis/Comments
<i>Overall Goals</i>			
A)	<p>CARA Goal & Objectives: The purpose of this CARA Plan is to eliminate blighting influences found in the CARA, to implement goals and objectives of the City of Albany Comprehensive Plan, and to implement development strategies and objectives for the CARA. The goal and objectives for the CARA have been defined as follows:</p> <p>CARA Goal: To revitalize the Central Albany Revitalization Area by implementing the Town Center Plan developed through the Central Albany Land Use & Transportation Study (CALUTS) using a citizen-driven process.</p>	<p>Does the project further the Town Center Plan?</p> <p>Which of CARA’s objectives does the project meet?</p> <p>CARA Key Objectives:</p> <ul style="list-style-type: none"> ◆ Attract new private investment to the area. ◆ Retain and enhance the value of existing private investment and public investment in the area. <p>CARA Additional Objectives:</p> <ul style="list-style-type: none"> ◆ Provide a safe and convenient transportation network that encourages pedestrian & bicycle access to and within the town center. ◆ Preserve the Historic Districts, historic resources and existing housing in the area. ◆ Create a readily identifiable core that is unique and vibrant with a mixture of entertainment, housing, specialty shops, offices, and other commercial uses. ◆ Increase residential density in the area. ◆ Encourage the development of new forms of housing and home ownership. ◆ Enhance and protect the community and environmental values of waterway corridors in the area. ◆ Provide an enriching environment and livable neighborhoods. 	<p>Yes.</p> <p>This project meets CARA's two key objectives as listed.</p> <p>Additional objectives met:</p> <p>Historic preservation Readily identifiable core Enriching environment</p>
B)	<p>CARA Planned Projects</p>	<p>Which project category and activity in the UR Plan does this project fulfill? (See CARA Project Activities document, or Table 2 of the UR Plan and Report.)</p>	<p>Commercial Building Rehabilitation, Storefront Revitalization</p>
C)	<p>Development Pattern (Highest and Best Use)</p>	<p>Does it achieve desired land use (e.g., mixed-use, higher density) and/or transportation objectives (e.g., Esplanade, pedestrian-friendly areas)? Is the proposed project desired in this location and the highest and best use of the property?</p>	<p>Zone: Lyon-Ellsworth</p> <p>Yes, the project fits within options for highest and best use for this property.</p>
D)	<p>Blight</p>	<p>Would it remedy a severely blighted building? How? Does the project utilize a vacant space?</p>	<p>Yes, project activates a currently vacant building.</p>

E)	Preservation	Would it rehabilitate or sensitively redevelop a historic property?	Yes.
F)	Vitality/People Attractor	Does the general public benefit (i.e. restaurant, carousel, something they can go to; does the project enhance the public's experience of the space; is it a business we are seeking)?	Yes, facilitates expansion of an existing restaurant.
G)	Retail Hotspot (First Avenue between Lyon and Calapooia)	Is the project located in the Retail Hotspot? If so, will the first floor use be active retail, as recommended in the Retail Refinement Plan?	No, this project is not located within the retail hotspot.
H)	Sustainable Building	Will the building be built using sustainable practices including LEED or others?	Not identified in application.
I)	Residential	Is there a residential component? How many units?	No.
<i>Economic Development</i>			
J)	Bring new business to Albany	Will a new business open or come to Albany as a part of this project?	No.
K)	Job Creation	Will the project create additional jobs? How many, what types and what salary level?	Yes, three part-time positions. Salary level not identified.
L)	Local Labor and Materials	Has applicant specifically called out a commitment to use a certain percent or amount of local labor and/or materials?	Yes, commitment to use local contractors for this project.
<i>Financial</i>			
M)	Ratio	Proposed public funds Private funds % of CARA Investment	Applicant requesting 75% of total project costs for this phase.
N)	Financial Impacts	What are the financial risks and/or financial benefits to CARA?	Reimbursement based-grant; low financial risk. Benefits through increased value.
O)	Gap	What is the "Gap" or need of the developer?	\$421,770
P)	Private Risk	What is the risk for the developer? What is their skin in the game?	\$140,589 for this phase of the project.
Q)	CARA/City funds	Has the project received other CARA/City funding in the past?	No.
R)	Tax Increment ROI	Is the ROI on this project less than 5 years, less than 7 years?	ROI will be achieved through increased property value.



CARA GRANT APPLICATION

1. APPLICANT

Name: Caitlin Prueitt for Calapooia Brewing

Mailing Address: 140 NE Hill Street
Albany, OR Zip Code: 97321

Title: Owner Phone Number: [REDACTED]

E-mail Address: [REDACTED]

2. BUSINESS/BUILDING INFORMATION

Legal Business Name: Veracity Spirits LLC, dba Calapooia Brewing, dba Vivacity Spirits

Number of Years in Operation: 15

Legal Form: Sole Proprietorship Partnership Corporation S-Corp LLC
 Profit Nonprofit

EIN: [REDACTED]

In which state are the incorporation and/or organization documents filed? Oregon

Have you ever filed for bankruptcy? Yes No

Project Address (if different than mailing address): _____

Property Tax Account Number: 83051

Is the building a historic contributing resource? Yes No

If so, is it on the historic property-tax freeze? Yes No

3. OWNER OF PROPERTY (if not applicant)

Name in which title is held: Water Hill LLC

Contact Name: Caitlin Prueitt

Mailing Address: [REDACTED]
[REDACTED] Zip Code: [REDACTED]

Phone Number: [REDACTED]

4. AUTHORIZATION TO UNDERTAKE WORK:

If the applicant is not the owner of the property, provide written evidence that the owner authorizes this work to be undertaken. (Typically this is in the form of a lease or other written permission.)

5. DESCRIPTION OF PROJECT *Please give a comprehensive description of project.*

Most of the windows in the building are in various states of disrepair. It is assumed that these are the original windows from construction in the early 1940's. (This building is NOT on the historical building list)
 We are asking for help with replacing the windows in the customer facing areas of the property. First and foremost this would be in the pub dining room. Additionally there are windows in a section that is rented out to another business, Easton's Barber Shop.
 All the front facing windows are landscape style (one large thick pane of glass). There are wooded frames which are not in sound shape (when washing windows with a hose from the outside, water drips inside!).
 The windows on the sides of the pub (one facing Water Street, the other facing the "atrium" section of the building) are single pane, quite thin, with metal sash bars (or glazing bars). There are a number of cracked panes in these side facing windows. We are concerned that a child or person leaning on the glass will break through the panes.
 Replacing the windows would not only enhance the visual attributes of the facade, it would increase safety as well as energy efficiencies.

6. TIMELINE FOR COMPLETION OF PROJECT: Project could be finished before end of year 2026

7. PROJECT COSTS

ESTIMATED COST OF PROJECT: \$ 61,210

ESTIMATED VALUE OF PROJECT UPON COMPLETION: \$ \$75,000-150,000

Basis for valuation and value upon completion: Estimated value is based on increase in building value as well as energy savings for the next decade.

SOURCES FOR PROJECT:

Owner/Company Contribution	<u>\$ 15,302</u>
Bank (estimated)	<u>\$</u>
Other private funds (please specify)	<u>\$</u>
Other governmental (please specify)	<u>\$</u>
CARA (proposed)	<u>\$ 45,907</u>
TOTAL SOURCES	<u>\$ 61,210</u>

Is your funding for these: available today applied for unknown at this time

USES FOR PROJECT:

Land and/or Building Acquisition	<u>\$</u>
Soft Costs (architectural, engineering, financing, and legal fees, and other pre- and post-construction expenses.) *	<u>\$</u>
Construction Costs *	<u>\$ 61,210</u>
Tenant Improvements	<u>\$</u>
Machinery/Equipment/Installation Costs	<u>\$</u>
Working Capital	<u>\$</u>
Other (please specify)	<u>\$</u>
TOTAL USES	<u>\$ 61,210</u>

*Please provide a detail of Soft Costs and of Construction Costs (Please attach).

8. PREPARATION OF COST ESTIMATES

Who prepared your cost estimates? 1.South Town Glass, 2.Lowes Pro Shop, 3.Fitzpatrick Paining

(If applicant prepared their own estimate, verification may be required. **Please attach minimum of two bids, preferably three.**)

Mailing Address: [REDACTED]

Phone Number: (502) 524-5004 E-mail Address: [REDACTED]

9A. EXPLAIN WHY CARA FUNDING IS NECESSARY TO INSURE PROJECT COMPLETION.

(Please provide a description of the financial gap requiring CARA assistance.)

The business does not have the funds to complete this work. This is a project that we have been trying to save for since acquiring the building in late 2019. However, with a building this old there are often other emergency maintenance projects that require immediate attention.

This CARA grant funding speaks directly to our needs and to providing a safe and secure customer experience.

9B. IF YOU DON'T RECEIVE THE FUNDS, WHAT COMPONENTS WILL BE DROPPED? WOULD THE PROJECT GET DONE WITHOUT CARA FUNDS? (Please provide a detailed explanation.)

This project will more than likely not get done if we do not receive this funding.

10. WHERE ELSE HAVE YOU LOOKED FOR FUNDING?

We have only looked in house for funding for this project. We have an account in which money is sequestered for the mission of major repairs and maintenance on the building. There are often more emergent projects necessary for the functionality of the businesses that arise which depletes our resources. For example, compressors failing for the coolers, glycol system maintenance, plumbing issues, etc. All this to say, it is not realistic to be able to save a sufficient amount of money for this project.

11. CONSIDERING THE PROJECT GOALS OUTLINED IN THIS APPLICATION, PLEASE IDENTIFY THE VALUE YOUR PROJECT BRINGS TO CARA.

The value of this project is borne primarily in securing the safety of the building, improving the visual appeal, and increasing energy efficiency.

The safety risk could, in the near future, be a significant enough to hamper operations. This holds particularly true in maintaining a viable commercial rental space at 130 NE Hill St, which currently houses the Barber Shop.

At present with cracked windows and rotting sills, the curb appeal of the window is greatly lacking.

Improving the quality of the windows not only improves the curb appeal, but also the energy efficiency, thus increasing the customer experience. This will help to attract customers in all seasons.

The grant will also increase the value and functionality of the building.

12. PLEASE OUTLINE ANY OTHER BENEFITS YOUR PROJECT PROVIDES.

(To Albany, and the area/neighborhood)

Maintaining the integrity of these parts of the building helps to maintain the integrity of the whole building and the multiple businesses that are supported through this site. (Primarily providing a better experience for the commercial rental unit at 130 NE Hill ST- Easton's Barber Shop)

As in any building, windows don't just provide a light source, they are also a primary barrier of inclement weather. The value of the building will decrease by the battered, old, and compromised functionality of the current windows.

Replacing the windows will ensure protection from the outside elements, and will likewise prevent damage to the inside.

13. HAVE YOU OR THIS PROPERTY RECEIVED CARA FUNDING AT ANY POINT IN THE PAST?

No Yes If so, amount \$ _____

FOR WHAT PROJECT(S): _____

WHEN? _____

14. ASSISTANCE REQUESTED

Total Estimated Project Costs:	\$ <u>61,210</u>
Your Total Contribution	\$ <u>15,302</u>
Total Amount Requested from CARA:	\$ <u>45,908</u>

Final payment will be based on actual costs not estimates. **Ten percent of CARA funds will be held back for final payment.**

15. BREAKDOWN OF USE OF CARA FUNDS

CARA funds can only be used for permanent improvements to the building. Please provide a breakout with specific details of how the CARA funds will be used in the project. If more space is needed, please attach a separate page.

Item	Amount	Notes
Window replacement - Pub	37210	140 NE Hill St, Pub dining area. Total 248 sq ft of windows
Window replacement - Barber Shop	24000	130 NE Hill St, Commercial Rental. Total 160 sq ft of windows
Less 25% building owner contribution	-15,302	
TOTAL	45,908	Total should match total amount requested from CARA from line 14.

Metrics and Other Benefits

If you receive funding, you will be asked to tally the final figures on the project and certify their accuracy. Please use this space to estimate the impact of your project:

Number of Jobs Created: _____ Full-time _____ Part-Time

Certification

The Applicant understands and agrees to the following conditions:

1. Any physical improvements proposed must be approved by the Albany Revitalization Area Agency (ARA) and may require approval by the City of Albany Landmarks Advisory Commission or other entities. These entities may require certain changes or modifications before final approval and Commitment of Funds.
2. Any work begun before receipt of a Contract notice is ineligible for reimbursement.
3. Any work deviating from that detailed in the Contract must be preapproved in writing to be eligible for reimbursement.
4. While only proprietary information may be held in confidence outside of the public record, ARA will attempt to maintain all information provided in a confidential manner.
5. Originals of all materials prepared with ARA assistance belong to ARA and will be maintained in the public record.
6. Application must be completed in its entirety before being considered; if not, it will be returned for completion.
7. Staff is authorized to independently verify any and all information contained in this application.
8. ARA may withhold approval of this application until information satisfactory to ARA is provided.

The Applicant certifies that all information in this application and all information furnished in support of this application is given for the purpose of obtaining ARA assistance and is true and complete to the best of the Applicant's knowledge. Applicant further acknowledges the undersigned applicant(s) have read and understand CARA's privacy policy and have completed this form with accurate information.

Caitlin Prueitt

Applicant's Printed Name

Applicant's Printed Name

Applicant's Signature



Date

03/31/26

Applicant's Signature

Date

Return application/attachments to: City of Albany c/o Sophie Adams, Economic Development Manager: sophie.adams@albanyoregon.gov

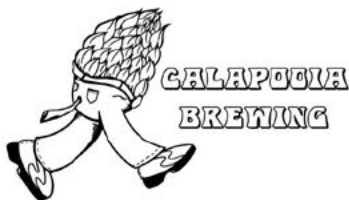

OREGON, USA
VIVACITY
 FINE SPIRITS

March 31, 2026

Central Albany Revitalization Area
 333 Broadalbin Street SW
 Albany, OR 97321

ADDENDUM TO QUOTES:

Thank you for reviewing our application for the upcoming CARA grant.

It came to light during the process of obtaining quotes for this project that the process is not as straight forward as anticipated. There are various ways to approach or quote this type of work, as well as various reasons not to be able to quote the work at all.

I ask that consideration is taken knowing that there are qualified and eager contractors for the job who were able to quote the work, and others who had time and resource constrictions in getting a quote done in a timely manner.

Southtown Glass approaches it from a square foot perspective. As they created the quote from a phone call they missed some of what was verbalized to them, specifically the quantity of windows to be replaced. With Jeremy Moore's permission, the quote they sent over has been altered to reflect those changes, ultimately costing about \$150/square foot of window, to include demo and install.

Fitzpatrick Painting and Construction visited the site on March 16 and has since been waiting to consult with a glass specialist to get a materials quote. As of today they said this would happen around mid April.

Lowe's Pro shop quoted the materials only, and state they cannot quote labor until the job is approved and assigned to an actual contractor. The name Dani Raiche on the quote auto-filled when given the address because she is both the head brewer and a tenant and had initiated other small projects with Lowes.

Other contractors that we contacted weren't able to quote for reasons including: the building is too old and they aren't licensed to work with potential lead or asbestos, many only work residential, another has too much work lined up (great problem!), another thought the scope of the work was too big for them to handle. Another was simply retiring.

Thank you for your consideration,

[REDACTED]
 Caitlin Prueitt
 Calapooia Brewing, Vivacity Spirits



140 NE Hill
Fitzpatrick Painting
37949 Century Drive NE
Albany, OR 97322

INVOICE

INVOICE
131772

INVOICE DATE
3/16/2026

BILL TO
Calapooia Brewing
140 Northeast Hill Street
Albany, OR 97321 USA

JOB ADDRESS
Calapooia Brewing
140 Northeast Hill Street
Albany, OR 97321 USA

CUSTOMER PO
DUE DATE 3/16/2026
JOB TYPE ● Quote - Carpentry

DESCRIPTION OF WORK

SUB-TOTAL \$0.00

TOTAL DUE \$0.00
PAYMENT \$0.00

BALANCE DUE \$0.00

Lowe's Home Centers, LLC



3057 236852279 03/27/26

Quantity	Item #	Item Description	Vendor Part#	Price
4	5737115	Build to quote LINE#10 QT #20599739		\$9,068.48
1	5737115	BUILD TO QUOTE LINE#15 QT #20599739		\$1,043.52
1	5737115	Build to quote LINE #20 QT #20599739		\$877.15

\$10,989.15

* \$0.00

* \$0.00

* \$0.00

* \$10,989.15

*Freight, Delivery and Taxes will be calculated at checkout.
03/27/2026.

 Manager Signature

 Date

THIS ESTIMATE IS NOT VALID WITHOUT MANAGER'S SIGNATURE. THIS IS AN ESTIMATE ONLY. DELIVERY OF ALL MATERIALS CONTAINED IN THIS ESTIMATE ARE SUBJECT TO AVAILABILITY FROM THE MANUFACTURER OR SUPPLIER. QUANTITY, EXTENSION, OR ADDITION ERRORS SUBJECT TO CORRECTION. CREDIT TERMS SUBJECT TO APPROVAL BY LOWES CREDIT DEPARTMENT.

LOWES IS A SUPPLIER OF MATERIALS ONLY. LOWES DOES NOT ENGAGE IN THE PRACTICE OF ENGINEERING, ARCHITECTURE, OR GENERAL CONTRACTING. LOWES DOES NOT ASSUME ANY RESPONSIBILITY FOR DESIGN, ENGINEERING, OR CONSTRUCTION; FOR THE SELECTION OR CHOICE OF MATERIALS FOR A GENERAL OR SPECIFIC USE; FOR QUANTITIES OR SIZING OF MATERIALS; FOR THE USE OR



Project: Calapooia Brewing - Albany
 Client: Caitlin Prueitt
 Architect:
 Project location: Albany Or
 Budget date: 02.25.2026

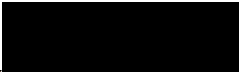

DOCUMENTS FOR BUDGET BASIS

Customer supplied photos

PRIMARY FACADE ELEMENTS

Wall Type	Quantity	U.O.M.	Rate	Total	Description
Kawneer 451T Storefront System	177	SF	\$60.00	\$10,620.00	2" x 4-1/2" Thermally Broken System for 1" Infill (Choose Infill Option Below)
Demo Existing Wood Windows Sash and Glass	177	SF	\$60.00	\$10,620.00	2" x 4-1/2" Thermally Broken System for 1" Infill (Choose Infill Option Below)
SUBTOTAL	354	SF		\$21,240.00	

ALLOWANCES

Quantity	U.O.M.	Rate	Total	Description
170	SF	\$23.00	\$3,910.00	ALLOWANCE - 1/4" Clear w/Solar Ban 60 Low E #2 - 1/2" Spacer (Argon) - 1/4" Clear (VLT=70%) (Winter U-Value=.24) (SHGC=.39) (Installation Included in Above Systems)
TOTAL			\$25,150.00	

QUALIFICATIONS

- 01 This Rough Order Magnitude (R.O.M.) estimate it is generally made with limited information. The typical range of estimates for ROM is -25% to +75%. However, this percentage may vary depending on how much is known by the project team about the project while creating or updating this estimate.
- 02 Conceptual budget is based on limited information as currently received.
- 03 Assumes all onsite activities to be performed during normal working hours.
- 04 Mutually agreed upon schedule.

EXCLUSIONS

- 01 Acoustic glazing, systems, specific performance, values or testing other than indicated above.
- 02 NFRC certifications or testing.
- 03 Thermal performance values other than indicated above.
- 04 Fire rated assemblies of any kind.
- 05 Bird protection of any kind.
- 06 2nd shift or Saturday work.
- 07 Sill extensions or convector covers
- 08 Interior finishes.
- 09 Final cleaning.
- 10 Interior or second line caulk joints.
- 11 Signage.
- 12 Grouting of embed block outs or cutting of deck.
- 13 Roofing, membranes, flashing, except as indicated above.
- 14 Payment and performance bonds.
- 15 Parking
- 16 Flashings
- 17 Weather Barriers / Waterproofing
- 18 Embeds
- 19 Demolition

END OF BUDGET



SOUTH TOWN GLASS IS NACC CERTIFIED - CERTIFICATION NUMBER: SOT01OR
 SOUTH TOWN GLASS IS (WBE) ORCOBID CERTIFIED - CERTIFICATION NUMBER: 14261
 SOUTH TOWN GLASS IS WASHINGTON (WBE) CERTIFIED - CERTIFICATION NUMBER: W2F0028822
 OR CCB: 104334 WA: SOUTHtg97214



As per Jeremy Moore of South Town Glass, this quote is amended to reflect the actual square footage of the project.

Final Quote amount = \$ 61,200

This includes 8 windows with a total of 408 square feet at \$150 per square foot to include demo installation of all windows.



Project Evaluation Grid: 140 NE Hill Street

Request: \$45,907

	Item	Description	Staff Analysis/Comments
<i>Overall Goals</i>			
A)	<p>CARA Goal & Objectives: The purpose of this CARA Plan is to eliminate blighting influences found in the CARA, to implement goals and objectives of the City of Albany Comprehensive Plan, and to implement development strategies and objectives for the CARA. The goal and objectives for the CARA have been defined as follows:</p> <p>CARA Goal: To revitalize the Central Albany Revitalization Area by implementing the Town Center Plan developed through the Central Albany Land Use & Transportation Study (CALUTS) using a citizen-driven process.</p>	<p>Does the project further the Town Center Plan?</p> <p>Which of CARA's objectives does the project meet?</p> <p>CARA Key Objectives:</p> <ul style="list-style-type: none"> ◆ Attract new private investment to the area. ◆ Retain and enhance the value of existing private investment and public investment in the area. <p>CARA Additional Objectives:</p> <ul style="list-style-type: none"> ◆ Provide a safe and convenient transportation network that encourages pedestrian & bicycle access to and within the town center. ◆ Preserve the Historic Districts, historic resources and existing housing in the area. ◆ Create a readily identifiable core that is unique and vibrant with a mixture of entertainment, housing, specialty shops, offices, and other commercial uses. ◆ Increase residential density in the area. ◆ Encourage the development of new forms of housing and home ownership. ◆ Enhance and protect the community and environmental values of waterway corridors in the area. ◆ Provide an enriching environment and livable neighborhoods. 	<p>Yes.</p> <p>This project meets CARA's two key objectives as listed.</p> <p>Addition objectives met:</p> <p>Historic preservation Readily identifiable core Enriching environment</p>
B)	CARA Planned Projects	Which project category and activity in the UR Plan does this project fulfill? (See CARA Project Activities document, or Table 2 of the UR Plan and Report.)	Commercial Building Rehabilitation, Transition Areas Redevelopment
C)	Development Pattern (Highest and Best Use)	Does it achieve desired land use (e.g., mixed-use, higher density) and/or transportation objectives (e.g., Esplanade, pedestrian-friendly areas)? Is the proposed project desired in this location and the highest and best use of the property?	Zone: Waterfront District Yes, this business is the highest and best use of this property.
D)	Blight	Would it remedy a severely blighted building? How? Does the project utilize a vacant space?	No.

E)	Preservation	Would it rehabilitate or sensitively redevelop a historic property?	No.
F)	Vitality/People Attractor	Does the general public benefit (i.e. restaurant, carousel, something they can go to; does the project enhance the public's experience of the space; is it a business we are seeking)?	Yes, supports local business and event space.
G)	Retail Hotspot (First Avenue between Lyon and Calapooia)	Is the project located in the Retail Hotspot? If so, will the first floor use be active retail, as recommended in the Retail Refinement Plan?	No.
H)	Sustainable Building	Will the building be built using sustainable practices including LEED or others?	Not addressed in application.
I)	Residential	Is there a residential component? How many units?	Existing residential units not directly impacted by this project.
<i>Economic Development</i>			
J)	Bring new business to Albany	Will a new business open or come to Albany as a part of this project?	No.
K)	Job Creation	Will the project create additional jobs? How many, what types and what salary level?	No.
L)	Local Labor and Materials	Has applicant specifically called out a commitment to use a certain percent or amount of local labor and/or materials?	Not specifically called out in application.
<i>Financial</i>			
M)	Ratio	Proposed public funds Private funds % of CARA Investment	Applicant requesting 75% of total project costs.
N)	Financial Impacts	What are the financial risks and/or financial benefits to CARA?	Reimbursement based-grant; low financial risk. Benefits through increased value.
O)	Gap	What is the "Gap" or need of the developer?	\$45,907
P)	Private Risk	What is the risk for the developer? What is their skin in the game?	\$15,302
Q)	CARA/City funds	Has the project received other CARA/City funding in the past?	No.
R)	Tax Increment ROI	Is the ROI on this project less than 5 years, less than 7 years?	ROI will be achieved through increased property value.



CARA GRANT APPLICATION

1. APPLICANT

Name: Josh Oare & Tiesha Oare

Mailing Address: [REDACTED]

Zip Code: [REDACTED]

Title: _____ Phone Number: [REDACTED]

E-mail Address: [REDACTED]

2. BUSINESS/BUILDING INFORMATION

Legal Business Name: JTHO LLC

Number of Years in Operation: Pre-Operation

Legal Form: Sole Proprietorship Partnership Corporation S-Corp LLC
 Profit Nonprofit

EIN: [REDACTED]

In which state are the incorporation and/or organization documents filed? OR

Have you ever filed for bankruptcy? Yes No

Project Address (if different than mailing address): 212 1st Ave., Albany OR, 97321

Property Tax Account Number: 82251

Is the building a historic contributing resource? Yes No

If so, is it on the historic property-tax freeze? Yes No

3. OWNER OF PROPERTY (if not applicant)

Name in which title is held: _____

Contact Name: _____

Mailing Address: _____

Zip Code: _____

Phone Number: _____

4. AUTHORIZATION TO UNDERTAKE WORK:

If the applicant is not the owner of the property, provide written evidence that the owner authorizes this work to be undertaken. (Typically this is in the form of a lease or other written permission.)

5. DESCRIPTION OF PROJECT *Please give a comprehensive description of project.*

See attached document.

6. TIMELINE FOR COMPLETION OF PROJECT: May 2026 to October 2026

7. PROJECT COSTS

ESTIMATED COST OF PROJECT: \$ 48,800
ESTIMATED VALUE OF PROJECT UPON COMPLETION: \$ 58,000-100,000
 Basis for valuation and value upon completion: See attached document

SOURCES FOR PROJECT:

Owner/Company Contribution	\$ <u>12,100</u>
Bank (estimated)	\$ _____
Other private funds (please specify)	\$ _____
Other governmental (please specify)	\$ _____
CARA (proposed)	\$ <u>36,700</u>
TOTAL SOURCES	\$ <u>48,800</u>

Is your funding for these: available today applied for unknown at this time

USES FOR PROJECT:

Land and/or Building Acquisition	\$ _____
Soft Costs (architectural, engineering, financing, and legal fees, and other pre- and post-construction expenses.) *	\$ _____
Construction Costs *	\$ <u>48,800</u>
Tenant Improvements	\$ _____
Machinery/Equipment/Installation Costs	\$ _____
Working Capital	\$ _____
Other (please specify)	\$ _____
TOTAL USES	\$ <u>48,800</u>

*Please provide a detail of Soft Costs and of Construction Costs.

8. PREPARATION OF COST ESTIMATES

Estimates provided by several companies. See attached document.

Who prepared your cost estimates? _____

(If applicant prepared their own estimate, verification may be required. **Please attach minimum of two bids, preferably three.**)

Mailing Address: _____

Phone Number: _____ E-mail Address: _____

9A. EXPLAIN WHY CARA FUNDING IS NECESSARY TO INSURE PROJECT COMPLETION. *(Please provide a description of the financial gap requiring CARA assistance.)*

See attached document

9B. IF YOU DON'T RECEIVE THE FUNDS, WHAT COMPONENTS WILL BE DROPPED? WOULD THE PROJECT GET DONE WITHOUT CARA FUNDS? *(Please provide a detailed explanation.)*

If CARA funding is not awarded, the exterior restoration project will be placed on hold or completed incrementally as additional funding becomes available. Priority will continue to be given to operating the business and maintaining the building's safety and functionality.

The exterior improvements would be revisited once the business is fully operational and able to generate additional revenue, or if other grant or funding opportunities become available. While the project would not be abandoned, CARA support would significantly accelerate completion and allow the improvements to be made in a timely and cohesive manner.

10. WHERE ELSE HAVE YOU LOOKED FOR FUNDING?

I applied for funding through the most recent Oregon Main Street Grant Program in 2025 to support roof replacement for my historic downtown Albany building. Although the application was not awarded, the roof had become a critical need and was completed using private funds.

I have also considered other financing options, including lines of credit. However, as I am in the process of starting a new business, I am intentionally limiting the use of debt to manage risk responsibly. As a result, I have prioritized self-funding essential improvements where possible and I am seeking CARA support to complete necessary exterior upgrades without overextending the business financially.

11. CONSIDERING THE PROJECT GOALS OUTLINED IN THIS APPLICATION, PLEASE IDENTIFY THE VALUE YOUR PROJECT BRINGS TO CARA.

See attached document.

12. PLEASE OUTLINE ANY OTHER BENEFITS YOUR PROJECT PROVIDES. (To Albany, and the area/neighborhood)

I've lived in Albany a majority of my life, and I've seen its transformation. While its industries have changed, it's still maintained a strong family-based appeal through the years. The west side of downtown has prospered and become considerably more popular over the years. I feel that this project will help establish an improvement wave to the east side of downtown and bring attention to new business and housing opportunities that further increases the consumer options for the people of Albany as well as increase employment opportunities.

13. HAVE YOU OR THIS PROPERTY RECEIVED CARA FUNDING AT ANY POINT IN THE PAST?

No Yes If so, amount \$ Unknown

FOR WHAT PROJECT(S): Previous owner and possibly commercial tenant projects

WHEN? Unknown

14. ASSISTANCE REQUESTED

Total Estimated Project Costs:	\$ <u>48,800</u>
Your Total Contribution	\$ <u>12,100</u>
Total Amount Requested from CARA:	\$ <u>36,700</u>

Final payment will be based on actual costs not estimates. **Ten percent of CARA funds will be held back for final payment.**

15. BREAKDOWN OF USE OF CARA FUNDS

CARA funds can only be used for permanent improvements to the building. Please provide a breakout with specific details of how the CARA funds will be used in the project. If more space is needed, please attach a separate page.

Item	Amount	Notes
Painting Building	\$13,900	2-3 Painter Crew
Ext. Wood	\$5,800	1 Person Crew
Masonry	\$17,000	2 Masonry Crew
TOTAL	\$36,700	Total should match total amount requested from CARA from line 14.

Metrics and Other Benefits

If you receive funding, you will be asked to tally the final figures on the project and certify their accuracy. Please use this space to estimate the impact of your project:

Number of Jobs Created: _____ Full-time 5-6 Part-Time

Certification

The Applicant understands and agrees to the following conditions:

1. Any physical improvements proposed must be approved by the Albany Revitalization Area Agency (ARA) and may require approval by the City of Albany Landmarks Advisory Commission or other entities. These entities may require certain changes or modifications before final approval and Commitment of Funds.
2. Contract will not be processed until the Applicant satisfies all conditions.
3. Any work begun before receipt of a Contract notice is ineligible for reimbursement.
4. Any work deviating from that detailed in the Contract must be preapproved in writing to be eligible for reimbursement.
5. While only proprietary information may be held in confidence outside of the public record, ARA will attempt to maintain all information provided in a confidential manner.
6. Originals of all materials prepared with ARA assistance belong to ARA and will be maintained in the public record.
7. Application must be completed in its entirety before being considered; if not, it will be returned for completion.
8. Staff is authorized to independently verify any and all information contained in this application.
9. ARA may withhold approval of this application until information satisfactory to ARA is provided.

The Applicant certifies that all information in this application and all information furnished in support of this application is given for the purpose of obtaining ARA assistance and is true and complete to the best of the Applicant’s knowledge. Applicant further acknowledges the undersigned applicant(s) have read and understand CARA’s privacy policy and have completed this form with accurate information.

Josh Oare

Tiesha Oare

Applicant’s Printed Name

Applicant’s Printed Name

Applicant’s Signature



Date 3/30/2026

Applicant’s Signature

Date 3/30/2026

Return application/attachments to: City of Albany c/o Sophie Adams, Economic Development Manager: Sophie.adams@albanyoregon.gov

CARA 2026 Attachment

5. Project Description

The project involves restoration of exterior building elements that have deteriorated over time due to weather exposure. One primary area of concern is the eastern exterior wall, where the brick and mortar show visible wear, particularly along the upper four to five feet. Most of this wall is partially protected by the adjacent apartment building to the east, which has limited damage to the exposed upper section.

Additional restoration is needed for various exterior wood features around the building. The awning, rear elements, and window trim exhibit varying degrees of dry rot. During a recent major windstorm, sections of window trim and decorative panels were blown off and fell to the ground below. While no people or property were harmed, this incident highlights an ongoing safety concern that should be addressed proactively.

Once these exterior repairs are completed, the project will conclude with a fresh coat of paint to revitalize the building's appearance and ensure long-term protection of the restored elements.

7. Basis for Valuation and Value Upon Completion

To establish a basis for valuation and the value upon completion, I will first gather information on market comparisons, then summarize them based off a couple of conditions.

See the following table that compares my building with similar buildings in the downtown area.

Address	Condition at Sale / Listing	Price	Building Size (SF)	\$ per SF	Notes
212 SE 1st Ave (Subject Property)	Deferred exterior maintenance	\$500,000	4,136	\$121/SF	Paint failure, dry rot, mortar loss
Market Comps					
424 1st Ave SW (Bike n Hike Bldg.)	Tired / visible exterior wear	\$649,000	7,264	\$89/SF	Deferred exterior condition, large shell
331 1st Ave W	Clean but dated	\$420,000	4,025	\$104/SF	Functional but not polished

309 1st Ave (“Western Union”)	Polished / turn-key historic	\$650,000	4,800	\$135/SF	Restored exterior, strong curb appeal
213 Water Ave NW (“Avery Mill”)	Polished / renovated	\$965,000	7,000	\$138/SF	Restored landmark building

Key notes:

- The building was acquired at \$121 per square foot, reflecting visible exterior deterioration rather than functional obsolescence.
- Comparable historic buildings on the same downtown blocks that have restored facades consistently support \$135–\$145 per square foot.
- The proposed repairs correct paint failure, wood decay, and masonry deterioration (factors causing the current discount).
- As a result, the project is expected to raise the building’s market value by approximately \$14–\$24 per square foot, creating **\$58,000–\$100,000** in long-term value while preserving a contributing historic structure.

In summary, the proposed façade improvements will increase the value of the property by increasing its curb appeal that will attract community and visitors to the area. It will help preserve and maintain the quality of the building, which also improves its value.

8. Bid Summary

Work Type	Company	Date	Amount	Adjusted	Adjustment Note
Painting	Blue Diamond	2/6/2025	\$15,120	\$16,027	Increased due to increases in cost of living and material costs from last year
Painting	Fitzpatrick Painting & Construction	3/9/2026	\$21,212	\$21,212	No adjustment
Painting	Stom Painters	1/20/2025	\$12,303	\$13,041	Increased due to increases in cost of living and material costs from last year
Ext. Wood	Sawright Construction	9/26/2024	\$9,500	\$9,000	Decreased because some items are no longer in scope. However, kept estimate relatively close due to an increase in cost of living and materials.

Ext. Wood	White Buffalo Construction	3/11/2026	\$5,940	\$5,940	No adjustment
Ext. Wood	Fitzpatrick Painting & Construction	3/9/2026	\$6,005	\$6,005	No adjustment
Masonry	Fredinburg Masonry Inc.	3/20/2026	\$20,540	20,540	No adjustment

8.1 Bid Assumptions and Notes

- 1) Adjustments were made to estimates that were over a year old to account for cost of living and material increases. Research indicated this was roughly 6%, so the Blue Diamond and Stom Painters estimates were increased by 6%.
- 2) The Sawright estimate decreased slightly because some items in the quoted have already been fixed, the decrease is minor, but worth noting as its significantly higher than the other quotes.
- 3) The Masonry quote is only one bid. Masonry is very limited in the area, let alone companies that are willing to do repair on historic buildings. Fredinburg was very reasonable in their approach. Another company did provide a bid, but they did not stay within the project's scope, so they did not meet the criteria for citing a reference.

8.2 Estimate Summary

	Min	Max	Average	Avg W/ 10% Cont.	CARA	Mine
Painting	\$13,041	\$21,212	\$16,800	\$18,500	\$13,900	\$4,600
Ext. Wood	\$5,940	\$9,000	\$7,000	\$7,700	\$5,800	\$1,900
Masonry	\$20,540	\$20,540	\$20,500	\$22,600	\$17,000	\$5,600
Total	\$39,521	\$50,752	\$44,300	\$48,800	\$36,700	\$12,100

8.3 Estimate Assumptions

- 5) Based off taking an average across the bids, 10% contingency was added for industry standard to account for unknown condition of structure behind fixed components
 - a. Example 1: Identifying further dry rot behind trim being replaced.
 - b. Example 2: Pressure washing identifies larger than expected scraping and priming before painting.

9A.

CARA funding is essential to complete exterior improvements to the building that will house Titan Valley Brewing, a new locally owned business intended to strengthen downtown Albany as a vibrant destination. Significant private investment has already been made to upgrade the interior and usability of the building as shown in the following table.

Projects	Cost (So Far)
Architect Services	\$8,200.00
SDCs and Permits	\$23,000.00
New Water Meter	\$3,000.00
Plumbing	\$7,700.00
Electrical	\$1,000.00
Walk in Cooler/Mezzanine	\$8,000.00
Roof	\$30,000.00
General Contracting	\$7,500.00
Total	\$88,400.00

Due to limited resources, these essential improvements were prioritized, delaying needed exterior work. CARA funding will allow the exterior to be restored and refreshed, improving the building's appearance, safety, and contribution to the downtown streetscape. These improvements will help activate the surrounding area, support economic activity, and align the building's exterior with the revitalization goals of Albany's downtown core.

11. Value of the Project to CARA

This project aligns with CARA's core strategies by supporting historic preservation, downtown revitalization, and local economic development. The building is a historic, registered property, and restoring its exterior will help preserve its character while improving its long-term viability. A refreshed exterior will contribute to a cleaner, more vibrant streetscape that encourages residents and visitors to shop, dine, and explore downtown Albany.

The project also supports continued investment and activity on the east side of downtown, helping balance growth across the downtown core. As the building will house Titan Valley Brewing, it contributes to Albany's emerging local brewing sector and strengthens this growing industry cluster by adding a locally owned destination business. Breweries play an important role in activating downtown areas, increasing foot traffic, and supporting surrounding businesses.

Improving the building's curb appeal can help catalyze additional private investment in nearby commercial, residential, or mixed-use properties. The project will also utilize local contractors for the restoration work, ensuring that CARA funding directly supports the local economy while enhancing the appearance, safety, and vitality of downtown Albany.

Appendix: Attached Bids

PROJECT PROPOSAL

BLUE DIAMOND PAINTING LLC
2/6/2025

CCB # 206210
3191 P.O BOX
ALBANY, OR 97321



Client Name Josh Oare
Phone Number [REDACTED]
Email [REDACTED]



ESTIMATE COST
\$15,120.00

PROJECT ADDRESS
121 SE 1st Ave
Albany OR 97321

JOB DESCRIPTION	AMOUNT
EXTERIOR PAINT Exterior paint include -Power wah -Scrape peeling off paint -Apply one coat of primer -Apply two coats of paint -Include paint, labor and supplies *Not include paint the windows *Not include city permits in case if we need it *The total price does not include any cost to work with lead if we found some on the building *Include Latitude Exterior Acrylic Latex paint from Sherwin Williams	\$15,120.00
TOTAL	\$15,120.00

CUSTOMER NAME _____ SIGNATURE _____

CONTRACTOR NAME _____ SIGNATURE _____



Proposal

March 20, 2026

To: Josh Oare

Subject: 212 First Ave. NE Albany, OR. 97321

Pages: 1 of 2

This will confirm my bid of **\$20,540** to provide labor, material, equipment, and cleanup to repair approximately a 50'x5' section of brick at the East Elevation from the street side to where the gas pipe runs down the face of the brick. This includes scaffolding, grinding and repointing at this section. This bid also includes renting a manlift, and grinding and repointing at the rear of the East elevation approximately the top 2'. This bid does not include any permits, or work with the historical consultant if required. Below is a breakdown of my bid.

East Elevation from street side to gas pipe: \$14,920

East Elevation rear of building: \$5620

Any additional work beyond these areas will be billed at \$85hr for a mason, and \$55hr for a laborer, plus any additional materials.

Breakdown

1. Scaffold
2. Manlift
3. Type O Mortar natural color
4. Grind damaged areas as per the description and locations
5. Pressure wash areas once ground out
6. Repoint using Type O Mortar
7. **Excludes permits for work or sidewalk closures**
8. **Excludes any Historical consultants or special permits if required**
9. **Excludes paint and sealer**
10. **Excludes joint sealants**
11. **Excludes any work at window frames**

Payment Terms: 50% Due upon scheduling of scaffold setup, and balance due upon completion

*Bids are valid for 30 days and Fredinburg Masonry reserves the right to lien property with the failure of payment within the terms stated or otherwise by the 10th of the month. Upon failure of payment within the accepted terms Fredinburg Masonry inc., may assess a late fee equal to 2% of the billed amount. ***All bids are based on an accessible site Via forklift for material placement, and all utilities available.*

Thank you and we look forward to working with you in the future.

If you have any questions or would like to discuss this matter please feel free to contact me directly on my cellular phone at 503-932-1082. Thank you and we look forward to working with you in the future.

Respectfully,

Nick Fredinburg

*Bids are valid for 30 days and Fredinburg Masonry Reserves the right to lien property with the failure of payment within the terms stated or otherwise by the 10th of the month. Upon failure of payment within the accepted terms Fredinburg Masonry inc., may assess a late fee equal to 2% of the billed amount . ***All bids are based on an accessible site Via forklift for material placement, and all utilities available.*

Thank you and we look forward to working with you in the future.

About Your Estimator



Alphie Pantle
Carpentry Estimator

Alfred 'Alphie' Pantle joined the Fitzpatrick Painting and Construction Team in 2014 as a Lead Carpenter and has become a valued team member. He has also built a substantial network of returning clients since then. He is a Philomath High School Graduate (class of '84) and in 2001 he relocated to New York where he began his career in carpentry. It was there that he learned his trade through remodeling existing homes as well as building a private boat dock and house on lake George. This was also when he discovered a passion for diving and became certified. In 2013, Alphie came home to Oregon, got married, and has lived in Corvallis ever since. He has 6 children and 7 grandchildren and looks forward to continuing to grow with Fitzpatrick Painting and Construction.

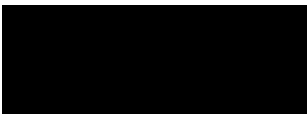

Alphie Pantle
Carpentry Estimator



Proposal

Fitzpatrick Painting & Construction
37949 Century Dr. NE
Albany, OR 97322



CCB# 169134

Contact

Josh Oare
SE 1st Ave
Albany, OR 97322



Proposal ID

18028

212 SE 1st Ave
Date

Mar 9, 2026

Expires

Apr 9, 2026

Item \$

Notes:

- **Owner is responsible for having all masonry issues resolved prior to painting**
- **Additional cost may occur for excessive amount of prep on masonries areas**
- Price listed includes lift rental
- Exact colors & sheens are unknown at this time unless clearly specified below
- Includes painting the home with Miller Acri- lite **low sheen** or *equivalent* product in the current scheme in colors of customer choosing. ONE color for body
- **Spot prime with masonry primer**
- All trim work to be faced off. Does not include French tipping/wrapping of outer trim (Paint Standard).
- All labor and materials are included. All discounts have been applied.
- *If your home has multiple layers of paint, there will be visible "hard lines" to varying degrees. Prepping, which includes scraping, priming and caulking will not produce an even, smooth or consistent finish on all surfaces of the home. We do not sand imperfections and or "hard lines" down to a smooth finish. Sanding on Lead Based Paint jobs is not allowed without specialty equipment and an ADDITIONAL charge if requested and possible.*
- Includes coating the home with Sherwin Williams Woodscapes Solid Body Stain (100% Acrylic). If customer prefers, SuperPaint can be used for the same price, but the solid body stain is recommended to help with multi-layer peeling. Higher sheen and thicker paints typically have a greater chance of multi-layer peeling.

The areas we are proposing to paint (scope of work):

Description of the Project and Description of the Significant Materials to be Used and Equipment to be Installed

Preparation as stated below:

ALL SIDES OF Building

Body - apply 2 coats.

Exterior Exclusions:

- All decks, steps and walking surfaces.
 - Railings.
 - Outbuildings.
 - All exterior concrete floor surfaces.
 - All roof surfaces and roof mounted items.
 - All other perimeter fencing and other landscape items.
 - Stained and or factory finished areas.
 - All other surfaces not specifically mentioned.
-

Included in our standard Exterior procedures:

- Treat all mold and mildew with 'Mold be Gone' or like solution to kill organisms.
 - Pressure wash all surfaces receiving finish to remove dirt, chalk, flaking paint and mildew.
 - Scrape all loose or chipping paint down to a well adhered surface.
 - Any loose caulking will be removed and re-caulked with a Lifetime Warranty. Includes caulking all open gaps around all windows, frames and critical junctions.
 - Prime all bare wood and cracking paint with resin primer/wood stabilizer or oil primer. (Dependent on surface).
 - All rusted metal or nail heads will be prepped properly to remove loose rust and primed with rust inhibitive primer.
 - Mask/protect all areas as needed (windows, walkways, landscaping, roof, etc.).
 - Apply Two coats of Miller AcriLite Satin or equivalent.
 - All paints used will contain a mildewcide additive. This greatly minimizes future mold and mildew growth on the paint.
 - All surfaces will be back brushed and rolled as required, to ensure proper adhesion.
 - Overhang will be painted the same color as the body unless clear stated differently below.
 - Paint the bottom edge of all siding boards where it meets the foundation as needed.
 - Painting the following entry doors (PREVIOUSLY PAINTED).
 - After completion of painting, all masking and painting debris will be removed and disposed of properly.
 - Price includes a touch up kit with clearly labeled containers for all paints used.
 - A one-hour professional color consultation with our designer is available for an additional \$200.00 above the below quoted price.
 - Home is presumed positive for Lead paint. (lead is found on many homes that were built prior to 1978) Lead safe work practices will be adhered to.
 - A thorough walk through will be done at the completion of the job by the crew lead with the customer. Payment will be collected by the crew lead.
-

Payment Terms

- We propose to furnish material and labor – complete and in accordance with the above specifications for the sum stated below. *Individual tasks, if selected, may require additional pricing. Price is valid for 30 days, unless otherwise noted.*
- **Final balance** is due upon the completion of the job. Credit Card Payments will not be accept for projects over \$50,000 without prior approval.
- Projects worked over a month end or jobs over \$10,000 may be subject to progress billing.
- Painting and Carpentry are two different project types and divisions. Each project type will be billed individually and payment is due upon receipt of your invoice.
- ***For payments made by credit or debit card, a 2.9% processing fee will be added on top of the contract amount and will appear as a separate charge on the invoice.***

Deposit Information

Due upon approval of proposal (50%): _____

Payable by credit card or check.

**Deposit must be paid in order to hold your place in our schedule.*

Cost:

\$21,212.00

Cost:

- We propose to furnish material and labor – complete and in accordance with the above specifications for the sum stated below. *Individual tasks, if selected, may require additional pricing.* Price is valid for 30 days, unless otherwise noted.
- A 50% deposit is required to reserve your project. We will schedule your work once we receive a copy of this agreement and the requested deposit. Please make checks payable to Fitzpatrick Painting Inc.
- Final balance is due upon the completion of the job.
- Projects worked over a month end or jobs over \$10,000 may be subject to progress billing.

Carpentry Repairs :

- Right side (parking lot)
- * fabricate and install new window trim on three windows
- Front side (street)
- * replace 40ft of 1x4 & 24ft of 1x6 trim on soffit front and left side
- ** Forest trim material to be installed
- * replace the 3 pieces of window trim on left lower window
- ** 1x6 forest trim to be installed
- Back wall (alley)
- * remove the existing soffit (30ft)
- **Install new 1x12 Forest trim material to form bottom and front of new soffit
- * replace the 20ft of T1-11 siding
- ** 4" OC plywood siding to be installed
- * install 1x4 forest trim of both sides for edge trim
- * replace 30ft brick molding trim

Total \$27,217.00

Options

These items are optional additions and are not included in the total.

Item \$

Now that you have invested thousands of dollars into what is quite possibly your most valuable asset, let's make sure it's protected correctly!

We have three maintenance options listed below for you. Please choose the one that best fits your needs. We will take care of the rest!

BASIC:

- Treating home to kill all mold and mildew spores as required.
- Washing your home once per year. Scheduled in Dec, Jan or Feb.
- A visual inspection of all critical joints, painted surfaces and penetrable surfaces.
 - **PER YEAR INVESTMENT -**

ENHANCED:

- Treating home to kill all mold and mildew spores and growth as required.
- Washing your home once per year. Scheduled in Dec, Jan or Feb.
- A visual inspection of all critical joints, painted surfaces and penetrable surfaces.
- Treating the roof with a zinc powder solution to minimize mold and mildew growth.
 - **PER YEAR INVESTMENT -**

ALL INCLUSIVE:

- Treating home to kill all mold and mildew spores and growth as required.
- Washing your home once per year. Scheduled in Dec, Jan or Feb.
- A visual inspection of all critical joints, painted surfaces and penetrable surfaces.
- Treating the roof with a zinc powder solution to minimize mold and mildew growth.
- Manually cleaning gutters of all debris.
- Closing all foundation vents on the home - customer to provide vent covers.
- Install covers on all hose bibs - customer to provide hose bib covers.
 - **PER YEAR INVESTMENT -**

If all of the above mentioned services are declined, customer understands that Fitzpatrick Painting & Construction will warranty my paint job for a period of 8 years. I have been informed of the importance of washing my home yearly by my foreman or the salesmen and accept all inherent risks.

Notes:



IMG_6113.jpeg



IMG_6094.jpeg



IMG_6096.jpeg



IMG_6095.jpeg



IMG_6114.jpeg



IMG_6115.jpeg



IMG_6110.jpeg



IMG_6108.jpeg



IMG_6107.jpeg



IMG_6117.jpeg



IMG_6105.jpeg



IMG_6112.jpeg



IMG_6103.jpeg



IMG_6102.jpeg



IMG_6101.jpeg



IMG_6100.jpeg



IMG_6099.jpeg



IMG_6098.jpeg



IMG_6116.jpeg



IMG_6109.jpeg



IMG_6104.jpeg



IMG_6106.jpeg



IMG_6111.jpeg



IMG_6097.jpeg



IMG_6095.jpeg



IMG_6099.jpeg



IMG_6102.jpeg



IMG_6103.jpeg



IMG_6097.jpeg

Please read this proposal carefully and make sure that it contains all the aspects of the job that you want and no additional aspects. Anything not included in this proposal is excluded. We want to be as clear as possible to make this project easier for you. Please let us know of any way we can help.

Colors and Samples

- If your need assistance with color, we offer Color Consultations and custom color mixing. Additional costs do apply.
- Due to the conceptual nature of our first meeting and not having a color scheme finalized, additional pricing may be required on multiple colors, color placement or deep based colors.

Insurance

- Liability and Workers Compensation Insurance certificates are available upon request. These types of insurances are there for your protection as well as the protection of Fitzpatrick Painting and Construction employees.

Warranty

Lifetime Warranty - See attached warranty documents for specifics.

Payment

- A 50% deposit is required to reserve your project. We will schedule your work once we receive a copy of this agreement and the requested deposit. Please make checks payable to Fitzpatrick Painting Inc.
- The final balance is due upon completion of the project and will be collected on site.
- Projects worked over a month end or jobs over \$10,000 may be subject to progress billing.

Customer Responsibility

- Please take specific note of job description.
- Colors must be chosen one (1) week prior to start date. An additional cost will be charged for color changes made after commencement of work.
- Alarms and automatic sprinkler systems must be turned off while work is in progress.

Notes About the Job

- Amount above assumes that the existing paint is lead free. Amount subject to change if lead is found in any of the existing paint.
- At the completion of the project, our trained foreman will carefully inspect all surfaces to insure our quality standards have been met. This way, the customer will see only a high quality finished result.
- This contract is based on a regular workweek of Monday through Friday, standard business hours. If your project requires a different time schedule, this will need to be discussed for additional charges.
- We understand that the scope of work calls for a certain number of coats per surface to ensure proper coverage. In certain situations of color/finish selection or type of surface being painted, the allowed amounts of coats may not cover per the estimated scope of work. If this situation occurs, the customer will be notified and informed that additional coats will be required to ensure proper coverage and a professional looking paint job.
- Complete cleanup will be strictly observed at the end of each working day. All materials and tools will be moved or stored in a location as directed by the customer at the end of each day to minimize interruption of our customer's personal life style.
- This contract is for completing the job as described above and is based on visually observed conditions. Should any unforeseen conditions arise that could not be determined at the time of the estimate but does occur at any time for the duration of the project, the customer will be notified, and a firm price will be given at that time.
- **Pressure wash all surfaces scheduled for painting. The owners should be aware that when pressure washing is done, water is applied at angles not common to weather which will / may cause temporary leaking. For this reason, we strongly advise the customer to remove any items from around doors and windows that may be damaged by water.**
- Customer will be refunded the entire deposit, less a \$250.00 processing fee so long as the project is cancelled no less than 3 business days prior to the scheduled start date.
- All additional color changes will incur a charge of \$250 per color.

- Fitzpatrick Painting & Construction retains the right to terminate this contract at any point in the process.

Additional Work Orders

- If after you agree to this work, you desire any changes of additional work, please contact us as the cost of **all** revisions must be agreed upon in writing. Workers are instructed not to undertake additional work without authorization.
- It is essential that the work area be available to us, **free from other trades**. As a result of trade interference, Fitzpatrick Painting, Inc. may leave the job and additional charges may be incurred.
- All work is to be performed according to standard painting sequencing and work flow. If interruptions occur, additional charges may be incurred.

Schedule

- ESTIMATED TIMELINE TO BEGIN PROJECT:
- ESTIMATED PROJECT LENGTH:

Terms and Conditions and Attachments

- **Incorporation of Terms**

The Terms and Conditions following, and all Attachments, are expressly incorporated into this Agreement. This Agreement constitutes the entire understanding of the parties, and no other understanding or representations, oral or otherwise, shall be recognized as part of this Agreement.

- **Management Review**

This Agreement is subject to periodic management review and may be amended or terminated at the discretion of management based on operational requirements, performance, or other relevant considerations.

- **Legal Fees**

If a legal dispute arises in connection with this Agreement, both parties agree to bear their own legal fees and costs. Neither party shall be entitled to recover attorney's fees from the other, regardless of the outcome.

Acceptance

(NOTE: This contract will expire if not accepted **within 30 days** of the date signed by Contractor.)

You're hereby authorized to perform the work specified in this Proposal & Agreement, for which I/we agree to pay the contract price; according to the terms. Any alteration or deviation from the above specifications, including but not limited to any such alteration or deviation involving additional material and/or labor costs, will be executed only upon written order for same, signed by Owner and Contract. If any payment is not made when due, Contractor may

suspend work on the job until such time as all payments have been made. A failure to make
payment for a
period in excess of 3 days from the due date of the payment shall be deemed a material
breach.

By signing this contract, **I/we have read and agree to the provisions of this Proposal and Agreement** and acknowledge receipt of the following: (1) Notice to Owner and Warranty, (2) Exterior Scope of Work, (3) Notice of Cancellation (listed below)

This contract is valid upon Fitzpatrick Painting and Construction managements approval.

Notice of Cancellation

You the buyer (Owner), may cancel this transaction at any time prior to midnight of the third business day after the date of this transaction, without forfeiting your deposit. Or, if this is a contract for the repair of damages resulting from an earthquake, flood, fire, hurricane, riot.



Estimator Signature

Date

Customer Signature

Date

Proposal #18028 for Josh Oare
Total value: \$27,217.00

Sawright Construction, LLC

1251 Sunset Ln.
Sweet Home, OR 97386

OR License # 211382

212 SE 1st Ave

Estimate

Date	Estimate #
9/26/2024	159

Name / Address
Josh Oare Albany, OR 97322

			Project
Description	Qty	Rate	Total
<p>WORK TO BE PERFORMED PER INSPECTION BY SERENITY INSPECTIONS, LLC AT 212 SE 1st. AVE. ALBANY, OR. 97321</p> <p>Repair/replace various exterior window and door trim on sides and front of building; and trim blocks at the half way wall height of exterior brick walls on sides of building; along with priming and painting same. Replace wood fascia where dry rot is currently on front awning, along with cutting back wood siding groove next to masonry and adding a butyl caulk. Add new flashing between front awning roof and brickwork/masonry. Replace deck steps along with framing under same. Repair current loose exterior handrail. Repair/replace fascia at back of building along with installing pressure treated boards along with flashing at bottom to separate siding from concrete. Install flashing & trim above door at rear entrance. MATERIALS & LABOR</p> <p>Manlift rental to perform sidewall work</p>		6,500.00	6,500.00
		3,000.00	3,000.00
		Total	\$9,500.00

Proposal #1299524

Josh Oare

212 SE 1st Ave
Albany, OR 97321



Proposal # 1299524
Proposal Date 1/20/2025
Proposal Amount \$12,302.62
Job Address 212 SE 1st Ave
Albany, OR 97321

Stom Painters Inc. License# CCB 153840
2500 Three Lakes Rd SE, Ste B
Albany, OR 97322

Line Items

Product / Service	Quantity
Exterior Painting - Pre 1978 Building Preparation: <ul style="list-style-type: none"> • Conduct a thorough pressure washing of the exterior surfaces to eliminate dirt, grime, and other contaminants, ensuring optimal adhesion of the paint. <ul style="list-style-type: none"> ◦ Use 30 Second Outdoor Cleaner to eliminate heavy grime/mildew growth • Wait the appropriate amount of days for substrates to dry out • Employ meticulous scraping techniques to remove any loose or peeling paint, exposing the substrate for a smooth and durable finish. <ul style="list-style-type: none"> ◦ Lay 4 Mil thick plastic 10 feet back from the walls to catch all paint chips ◦ Abide by Lead and EPA guidelines ◦ Create containments areas with signage and caution tape • No brick/mortar repairs will be done unless specified by the client <ul style="list-style-type: none"> ◦ Previously caulked surfaces will be re-caulked if applicable ◦ Re-Caulk All Windows (If Applicable) • Ensure accurate masking of all electrical, gas, and other meter labels • Apply rust-inhibiting primer to all HVAC piping, meters, and associated fixtures located on or connected to the home <ul style="list-style-type: none"> ◦ This allows for a beautiful blend of color to match the body of the building • Spot prime bare surfaces as needed <ul style="list-style-type: none"> ◦ Use Loxon Block Filler Masonry Primer • Plastic All Windows (If Applicable) • Mask and protect all surfaces/items not intended to be painted 	1.00
Application:	
<ul style="list-style-type: none"> • Utilize appropriate brushes, rollers, and sprayers to achieve optimal results, taking into account the texture and material of each surface. <ul style="list-style-type: none"> ◦ Product will be applied using an airless sprayer and followed by a back-rolling/brushing method to ensure full adhesion ◦ Trim work will be done with brush and roller ◦ Door will be accurately masked, and sprayed, and exterior 'edge' will be hand-brushed • Apply 2 coats of product, allowing sufficient drying time between coats to ensure durability and color vibrancy. • Pay special attention to detail during the painting process, addressing any imperfections or inconsistencies promptly to maintain a consistent and polished appearance. • Coordinate with the client to confirm color selections and any specific preferences, ensuring complete satisfaction with the final result. • Conduct a thorough inspection of all painted surfaces upon completion, making any necessary touch-ups or adjustments to achieve perfection. 	
Application Areas:	
<ul style="list-style-type: none"> • Repaint All Body Walls • Repaint All Fascia's <ul style="list-style-type: none"> ◦ Client will paint all Window Trim/Doors <ul style="list-style-type: none"> ▪ We will paint black door on left side of building with an airless sprayer • Repaint 2nd Story Window Trim and the "Schultz 1910" in the front of the building 	
Brand of Paint:	
<ul style="list-style-type: none"> • Sherwin-Williams 	
Product:	
<ul style="list-style-type: none"> • Loxon XP 	

Sheen:

- Flat or Low-Lustre

Color:

- Client's Choice, Color scheme/layout will remain the same configuration

This quote does not include:

- Window Trim
- Metal Railings
- Foundation
- Concrete Walkways, Porches, or Decks
- Screen Enclosure Metal
- Attached or Detached Structures unless otherwise stated

**Any unforeseen damages, repairs, or a change in color scheme will be an additional charge unless otherwise stated.*

Repeat Client Discount

1.00

Subtotal (\$2,171.04)

Tax \$0.00

Total (\$2,171.04)

Areas	Quantity
-------	----------

Front Side

Item

Paint Brick - Siding

Opening - Openings

Window Sash Painted - Window Frames

Washing Exteriors - Washing Exteriors

Back Rolling - Back Rolling

Prep

Right Side

Item

Paint Brick - Siding

Opening - Openings

Washing Exteriors - Washing Exteriors

Back Rolling - Back Rolling

Prep

Rear Side

Item

Paint Brick - Siding

Opening - Openings

Washing Exteriors - Washing Exteriors

Back Rolling - Back Rolling

Single Car Overhead Door - Overhead Garage Door

Prep

Left Side

Item

Paint Brick - Siding

Opening - Openings

Washing Exteriors - Washing Exteriors

Back Rolling - Back Rolling

Panel Door - Doors

Door Jambs - Door Jambs

Prep

Subtotal \$14,473.66

Tax \$0.00

Total \$14,473.66

Proposal Summary

Areas Total \$14,473.66

Line Item Total (\$2,171.04)

Proposal Total \$12,302.62

Deposit Required

212 SE 1st Ave

\$3,075.66 (25.00%)

Terms and Conditions

We propose hereby to furnish material and labor - complete in accordance with above specifications.

All material is guaranteed to be as specified. All work to be completed in a substantial workmanlike manner according to the specifications submitted, per standard practices. Any alteration or deviation from above specifications involving extra costs will be executed only upon written orders, and will become an extra charge over and above the estimate. If either party commences legal action to enforce its rights pursuant to this agreement, the prevailing party in said legal action shall be entitled to recover its reasonable attorney's fees and costs of litigation relating to said legal action, as determined by a court of competent jurisdiction. Client has a (3) day right to cancel without loss of deposit.

Sign And Date To Accept Proposal:

Customer Signature:

Date:



Prepared For

Josh Oare
212 SE 1st Ave
Albany, OR 97321

White Buffalo Construction

35146 Oakville Dr
Albany, Oregon 97321

Estimate # 6
Date 03/11/2026
PO # 202606
Business / Tax # 253053

Description	Total
West Side of Building Replace Trim on the Exterior Windows with cedar and marine plywood Replace all Decorative Panels	\$1,980.00
North Side of Building (Front) Replace All Awning 1x4 Fascia with FJP Cedar Replace All Exterior Front Window Trim with 1x4 FJP Cedar Replace Door Trim with 1x4 FJP Cedar	\$880.00
South Side of Building (Back) Replace Wood Trim around doors and sides with 1x4 and 1x6 FJP Cedar Replace All T1-11	\$2,282.50
East Side of Building Replace Deck Steps with pressure treated wood Repair Loose Handrail Replace 9 Decorative Rails with 1/2 marine plywood	\$797.50
Subtotal	\$5,940.00
Total	\$5,940.00

Notes:

Terms and Conditions

1. Existing Structure Conditions

This building, approximately 100 years old, may have hidden conditions such as deteriorated materials, concealed damage, structural deficiencies, or unforeseen conditions behind existing finishes or components. Any work required to address these conditions that is outside the original scope of work will be treated as additional work and may result in additional costs and/or schedule adjustments.

2. Scope of Work

The work included in this proposal is limited to the removal and replacement of the existing exterior panels and trim as described. Any structural repairs, brick repair, anchor repair, waterproofing, or other related work discovered after removal of existing materials is not included unless specifically listed.

3. Material Variations

Replacement materials will be selected to match the appearance of the existing building as closely as reasonably possible; however, due to the age of the building and availability of modern materials, an exact match cannot be guaranteed.

4. Unforeseen Conditions

If concealed damage, water intrusion, structural issues, or other unforeseen conditions are discovered during the course of work, White Buffalo Construction will notify the owner before proceeding. Any corrective work required will be completed only upon approval of a change order.

5. Site Protection

Reasonable care will be taken to protect surrounding surfaces and materials during construction. However, due to the age and condition of the building, existing materials such as brick, mortar, or trim may be fragile and may crack or break during removal of adjacent components.

6. Weather Conditions

Exterior work is subject to weather conditions. Delays due to rain, moisture, temperature limitations for paint, or other environmental factors may affect scheduling.

7. Payment Terms

A 30% deposit is required prior to the start of work in order to secure scheduling, materials, and mobilization. The remaining balance will be due upon completion of the project unless otherwise agreed upon in writing. Any additional work approved through change orders will be invoiced separately and may require additional deposits prior to commencement.



Project Evaluation Grid: 212 First Avenue

Request: \$36,700

	Item	Description	Staff Analysis/Comments
<i>Overall Goals</i>			
A)	<p>CARA Goal & Objectives: The purpose of this CARA Plan is to eliminate blighting influences found in the CARA, to implement goals and objectives of the City of Albany Comprehensive Plan, and to implement development strategies and objectives for the CARA. The goal and objectives for the CARA have been defined as follows:</p> <p>CARA Goal: To revitalize the Central Albany Revitalization Area by implementing the Town Center Plan developed through the Central Albany Land Use & Transportation Study (CALUTS) using a citizen-driven process.</p>	<p>Does the project further the Town Center Plan?</p> <p>Which of CARA's objectives does the project meet?</p> <p>CARA Key Objectives:</p> <ul style="list-style-type: none"> ◆ Attract new private investment to the area. ◆ Retain and enhance the value of existing private investment and public investment in the area. <p>CARA Additional Objectives:</p> <ul style="list-style-type: none"> ◆ Provide a safe and convenient transportation network that encourages pedestrian & bicycle access to and within the town center. ◆ Preserve the Historic Districts, historic resources and existing housing in the area. ◆ Create a readily identifiable core that is unique and vibrant with a mixture of entertainment, housing, specialty shops, offices, and other commercial uses. ◆ Increase residential density in the area. ◆ Encourage the development of new forms of housing and home ownership. ◆ Enhance and protect the community and environmental values of waterway corridors in the area. ◆ Provide an enriching environment and livable neighborhoods. 	<p>Yes.</p> <p>This project meets CARA's two key objectives as listed.</p> <p>Additional objectives met:</p> <p>Historic preservation Readily identifiable core Enriching environment</p>
B)	CARA Planned Projects	Which project category and activity in the UR Plan does this project fulfill? (See CARA Project Activities document, or Table 2 of the UR Plan and Report.)	Commercial Building Rehabilitation, Storefront Revitalization
C)	Development Pattern (Highest and Best Use)	Does it achieve desired land use (e.g., mixed-use, higher density) and/or transportation objectives (e.g., Esplanade, pedestrian-friendly areas)? Is the proposed project desired in this location and the highest and best use of the property?	<p>Zone: Central Business District</p> <p>Yes, this project is within highest and best use options for this property.</p>
D)	Blight	Would it remedy a severely blighted building? How? Does the project utilize a vacant space?	Yes, project activates a currently vacant building.

E)	Preservation	Would it rehabilitate or sensitively redevelop a historic property?	Yes.
F)	Vitality/People Attractor	Does the general public benefit (i.e. restaurant, carousel, something they can go to; does the project enhance the public's experience of the space; is it a business we are seeking)?	Yes, this project will facilitate a new business opening in Albany.
G)	Retail Hotspot (First Avenue between Lyon and Calapooia)	Is the project located in the Retail Hotspot? If so, will the first floor use be active retail, as recommended in the Retail Refinement Plan?	No, this project is not within the retail hotspot.
H)	Sustainable Building	Will the building be built using sustainable practices including LEED or others?	Not identified in application.
I)	Residential	Is there a residential component? How many units?	Not identified in application.
<i>Economic Development</i>			
J)	Bring new business to Albany	Will a new business open or come to Albany as a part of this project?	Yes.
K)	Job Creation	Will the project create additional jobs? How many, what types and what salary level?	Yes, undefined in application.
L)	Local Labor and Materials	Has applicant specifically called out a commitment to use a certain percent or amount of local labor and/or materials?	Yes, commitment to use local contractors for this project.
<i>Financial</i>			
M)	Ratio	Proposed public funds Private funds % of CARA Investment	Applicant requesting 75% of total project costs
N)	Financial Impacts	What are the financial risks and/or financial benefits to CARA?	Reimbursement based-grant; low financial risk. Benefits through increased value.
O)	Gap	What is the "Gap" or need of the developer?	\$36,700
P)	Private Risk	What is the risk for the developer? What is their skin in the game?	\$12,100 for this phase of the project.
Q)	CARA/City funds	Has the project received other CARA/City funding in the past?	The property has received funding in the past, this applicant has not.
R)	Tax Increment ROI	Is the ROI on this project less than 5 years, less than 7 years?	ROI will be achieved through increased property value.



CARA GRANT APPLICATION

1. APPLICANT

Name: Daren Clowser

Mailing Address: 230 Lyon St S #15 Albany, OR

Zip Code: 97321

Title: Owner

Phone Number: [REDACTED]

E-mail Address: [REDACTED]

2. BUSINESS/BUILDING INFORMATION

Legal Business Name: Knights of Pythias Building, LLC

Number of Years in Operation: 14

Legal Form: Sole Proprietorship Partnership Corporation S-Corp LLC
 Profit Nonprofit

EIN: [REDACTED]

In which state are the incorporation and/or organization documents filed? OR

Have you ever filed for bankruptcy? Yes No

Project Address (if different than mailing address): _____

Property Tax Account Number: 81741

Is the building a historic contributing resource? Yes No

If so, is it on the historic property-tax freeze? Yes No

3. OWNER OF PROPERTY (if not applicant)

Name in which title is held: Knights of Pythias Building, LLC

Contact Name: Daren Clowser

Mailing Address: 230 Lyon St S Unit 15 Albany, OR

Zip Code: 97321

Phone Number: _____

4. AUTHORIZATION TO UNDERTAKE WORK:

If the applicant is not the owner of the property, provide written evidence that the owner authorizes this work to be undertaken. (Typically this is in the form of a lease or other written permission.)

5. DESCRIPTION OF PROJECT *Please give a comprehensive description of project.*

The project for this building is to reframe and preserve the glass windows above the awning - Located at the building on the corner of 3rd and Lyon. All window casings have been deteriorating and need replacing.

Previously, it may be noted that there were CARA project records that indicate that some of this work has already been completed or at least funded by CARA in the past. To clarify, this is a completely different project. The project CARA helped with was to Paint & Seal the upper apartment windows. This project is dealing with the business upper windows above the awning of the building and the project is to reframe the casing around those windows.

6. TIMELINE FOR COMPLETION OF PROJECT: By the end of 2026

7. PROJECT COSTS

ESTIMATED COST OF PROJECT: \$95540

ESTIMATED VALUE OF PROJECT UPON COMPLETION: \$95540

Basis for valuation and value upon completion: _____

SOURCES FOR PROJECT:

Owner/Company Contribution \$23885

Bank (estimated) \$ _____

Other private funds (please specify) \$ _____

Other governmental (please specify) \$ _____

CARA (proposed) \$71655

TOTAL SOURCES \$ _____

Is your funding for these: available today applied for unknown at this time

USES FOR PROJECT:

Land and/or Building Acquisition \$ _____

Soft Costs (architectural, engineering, financing, and legal fees, and other pre- and post-construction expenses.) * \$ _____

Construction Costs * \$95540

Tenant Improvements \$ _____

Machinery/Equipment/Installation Costs \$ _____

Working Capital \$ _____

Other (please specify) \$ _____

TOTAL USES \$95540

*Please provide a detail of Soft Costs and of Construction Costs (Please attach).

8. PREPARATION OF COST ESTIMATES

Who prepared your cost estimates? Hurley Painting & Construction / Heritage Construction

(If applicant prepared their own estimate, verification may be required. **Please attach minimum of two bids, preferably three.**)

Mailing Address: PO Box 903 Albany, OR 97321 / 94590 Shadow Lane Gold Beach, OR

Phone Number: [REDACTED]

9A. EXPLAIN WHY CARA FUNDING IS NECESSARY TO INSURE PROJECT COMPLETION.

(Please provide a description of the financial gap requiring CARA assistance.)

The window framing has been deteriorating, along with crumbling of the facia and exterior framework due to the age of the building. We maintain it by patching it every year, but it is not a permanant fix. With the available CARA funds we can finally complete an appropriate solution to the problem that will be permanant. If we do not have the CARA funds, we will be forced to continue with a patch job. The funds will allow us to bring back and revitalize the historic beauty of the building. Also it will make for a more enjoyable shopping experience for customers for decades to come. This is a high visibility location that is good for all of downtown. CARA funds is needed to insure the completion of the project because the project is beyond my financial abilities. I am happy to invest and contribute where I can, but the only way this major project will be completed is by the help of CARA funding.

9B. IF YOU DON'T RECEIVE THE FUNDS, WHAT COMPONENTS WILL BE DROPPED? WOULD THE PROJECT GET DONE WITHOUT CARA FUNDS? (Please provide a detailed explanation.)

This project will not get done without the funds. We will have to continue to patch it every year and the framework will continue to deteriorate and get worse. This project cannot be completed without the help of CARA.

10. WHERE ELSE HAVE YOU LOOKED FOR FUNDING?

At this time CARA funds are needed as the means of getting the project done. I am seeking CARA funds because I feel like this project and CARA's mission is the closest fit, since one of CARA's main goals is to contribute to storefront revitalization and this project is for improvements on a mix-used downtown Albany historic building.

11. CONSIDERING THE PROJECT GOALS OUTLINED IN THIS APPLICATION, PLEASE IDENTIFY THE VALUE YOUR PROJECT BRINGS TO CARA.

This project is for a downtown historic residential and commercial mix use building. This project will help restore the window framing, facia boards and preserve the glass above the awning.

This project brings a lot of value that CARA is looking for in order to preserve the historic district, where multiple residents live. One value that this project brings is it will rejuvenate a high traffic corner of downtown and falls within CARA's goals of a vibrant downtown! It also preserves the historic structure. Another goal that fits into CARA's is this is a unique mix-used building with 15 residential units and four commercial spaces. This project will rehabilitate the existing structure and preserve its historical features that have been in Albany since 1913.

12. PLEASE OUTLINE ANY OTHER BENEFITS YOUR PROJECT PROVIDES.

(To Albany, and the area/neighborhood)

This project benefits the four commercial businesses that operate at the building and provides a better shopping experience for the hundreds of customers they serve every week. I want the building to continue to contribute to the revivment of downtown Albany. It is a great opportunity to display our historic and characteristic downtown!

13. HAVE YOU OR THIS PROPERTY RECEIVED CARA FUNDING AT ANY POINT IN THE PAST?

No Yes If so, amount \$ 10000

FOR WHAT PROJECT(S): Painting the exterior of the building

WHEN? Spring 2017

14. ASSISTANCE REQUESTED

Total Estimated Project Costs:	\$ <u>95540</u>
Your Total Contribution	\$ <u>23885</u>
Total Amount Requested from CARA:	\$ <u>71655</u>

Final payment will be based on actual costs not estimates. **Ten percent of CARA funds will be held back for final payment.**

15. BREAKDOWN OF USE OF CARA FUNDS

CARA funds can only be used for permanent improvements to the building. Please provide a breakout with specific details of how the CARA funds will be used in the project. If more space is needed, please attach a separate page.

Item	Amount	Notes
Equipment Rental	4240	
Material	30000	
Labor	60000	
Plywood Platform	500	
Glass Panels	800	Each if broken
TOTAL	95540	Total should match total amount requested from CARA from line 14.

Metrics and Other Benefits

If you receive funding, you will be asked to tally the final figures on the project and certify their accuracy. Please use this space to estimate the impact of your project:

Number of Jobs Created: _____ Full-time _____ Part-Time

Certification

The Applicant understands and agrees to the following conditions:

1. Any physical improvements proposed must be approved by the Albany Revitalization Area Agency (ARA) and may require approval by the City of Albany Landmarks Advisory Commission or other entities. These entities may require certain changes or modifications before final approval and Commitment of Funds.
2. Any work begun before receipt of a Contract notice is ineligible for reimbursement.
3. Any work deviating from that detailed in the Contract must be preapproved in writing to be eligible for reimbursement.
4. While only proprietary information may be held in confidence outside of the public record, ARA will attempt to maintain all information provided in a confidential manner.
5. Originals of all materials prepared with ARA assistance belong to ARA and will be maintained in the public record.
6. Application must be completed in its entirety before being considered; if not, it will be returned for completion.
7. Staff is authorized to independently verify any and all information contained in this application.
8. ARA may withhold approval of this application until information satisfactory to ARA is provided.

The Applicant certifies that all information in this application and all information furnished in support of this application is given for the purpose of obtaining ARA assistance and is true and complete to the best of the Applicant's knowledge. Applicant further acknowledges the undersigned applicant(s) have read and understand CARA's privacy policy and have completed this form with accurate information.

Daren Clowser

Applicant's Printed Name

Applicant's Printed Name

Applicant's Signature



Date 3/31/2026

Applicant's Signature

Date

Return application/attachments to: City of Albany c/o Sophie Adams, Economic Development Manager: sophie.adams@albanyoregon.gov



Prepared For

Daren Clouser
 32671 Berlin Rd
 Lebanon, Or 97355

Hurley Painting And Remodeling

PO Box 903
 Albany, Oregon 97321

Estimate # 197
 Date 03/17/2026
 Business / Tax # 202747

Description

Total

window replacement	\$95,540.00
equipment rental	\$4,240.00
Man lift needed to lift material and employees and create safe tie off point	
Material	\$30,000.00
exterior window frame 2x6 fir	
interior sections 1x4 pine	
trim out 3/4. trim	
ply wood to secure areas while working	
primer and paint to match current building scheme	
caulking/silicone and window glazing	
labor	\$60,000.00
2-3 guys	
plywood plat form	\$500.00
ply wood to build plat form and rack to hold glass as the re framing is done	
glass panels	\$800.00
If any are broken when pulled will be 800 per glass piece	

Subtotal	\$95,540.00
<hr/>	
Total	\$95,540.00

Notes:

Hurley Painting And Remodeling will construct a safety platform and rack to secure the existing glass. Subsequently, the glass will be meticulously removed in sections. Rotten and deteriorated wood will be removed and replaced with similar material. The glass will then be reinserted and sealed. This procedure will be applied to all sections measuring 20 feet by 6 feet.

WE ACCEPT the prices, specifications, and terms as stated in this bid proposal.

We hereby propose to furnish the materials and perform the labor necessary for the completion of Building of: See scope of work for details. With 50% down and balance due upon completion.

Credit card and online check payments will be subject to a 4% surcharge

Full payment will be expected upon completion. 1.5% interest will be added each month to outstanding balances.

In the event of a dispute, client/customer agrees to mediation of the dispute before litigation and assumes the obligation to pay for both parties' court costs and attorney fees if Hurley Painting and remodeling LLC is not found negligent.

Note: This proposal may be withdrawn by Hurley Painting and remodeling LLC if not accepted within 30 days.

By signing the proposal I have read and agree with the lien notices attached.

Daren Clowser

Heritage Construction NW LLC

94590 Shadow Ln

Gold Beach, OR 97444



CCB 229577

Bid: DGC

March 19, 2026

This bid is for window replacement in Albany, OR 97321

Bid includes : R&R of windows and surrounding casing

Equipment rental fees

Materials

Labor

Heritage Construction NW LLC can perform the above work for \$90,500. Due to the current state of the economy, prices of materials change weekly. Because of that, this bid is only guaranteed for 6 weeks. If within 6 weeks this bid is agreed upon then prices will be locked in upon securing 50% of payment for the products and scheduling. Any further damage found and/or any additional repairs that could affect new work being completed, structural integrity, or effect warranty will be discussed immediately upon discovery. Any change orders agreed upon after project has started that are not covered within the list above will result in a change order fee and work performed will be billed out at \$75/hr per person on site, unless a new bid is put in place.



Project Evaluation Grid: 230 Lyons Street S

Request: \$71,655

	Item	Description	Staff Analysis/Comments
<i>Overall Goals</i>			
A)	<p>CARA Goal & Objectives: The purpose of this CARA Plan is to eliminate blighting influences found in the CARA, to implement goals and objectives of the City of Albany Comprehensive Plan, and to implement development strategies and objectives for the CARA. The goal and objectives for the CARA have been defined as follows:</p> <p>CARA Goal: To revitalize the Central Albany Revitalization Area by implementing the Town Center Plan developed through the Central Albany Land Use & Transportation Study (CALUTS) using a citizen-driven process.</p>	<p>Does the project further the Town Center Plan?</p> <p>Which of CARA's objectives does the project meet?</p> <p>CARA Key Objectives:</p> <ul style="list-style-type: none"> ◆ Attract new private investment to the area. ◆ Retain and enhance the value of existing private investment and public investment in the area. <p>CARA Additional Objectives:</p> <ul style="list-style-type: none"> ◆ Provide a safe and convenient transportation network that encourages pedestrian & bicycle access to and within the town center. ◆ Preserve the Historic Districts, historic resources and existing housing in the area. ◆ Create a readily identifiable core that is unique and vibrant with a mixture of entertainment, housing, specialty shops, offices, and other commercial uses. ◆ Increase residential density in the area. ◆ Encourage the development of new forms of housing and home ownership. ◆ Enhance and protect the community and environmental values of waterway corridors in the area. ◆ Provide an enriching environment and livable neighborhoods. 	<p>Yes.</p> <p>This project meets CARA's two key objectives as listed.</p> <p>Addition objectives met:</p> <p>Historic preservation Readily identifiable core Enriching environment</p>
B)	CARA Planned Projects	Which project category and activity in the UR Plan does this project fulfill? (See CARA Project Activities document, or Table 2 of the UR Plan and Report.)	Commercial Building Rehabilitation, Storefront Revitalization
C)	Development Pattern (Highest and Best Use)	Does it achieve desired land use (e.g., mixed-use, higher density) and/or transportation objectives (e.g., Esplanade, pedestrian-friendly areas)? Is the proposed project desired in this location and the highest and best use of the property?	Zone: Lyon- Ellsworth Yes, mixture of uses fall within the highest and best use options for the property.
D)	Blight	Would it remedy a severely blighted building? How? Does the project utilize a vacant space?	No.

E)	Preservation	Would it rehabilitate or sensitively redevelop a historic property?	Yes.
F)	Vitality/People Attractor	Does the general public benefit (i.e. restaurant, carousel, something they can go to; does the project enhance the public's experience of the space; is it a business we are seeking)?	Supports existing commercial and residential uses.
G)	Retail Hotspot (First Avenue between Lyon and Calapooia)	Is the project located in the Retail Hotspot? If so, will the first floor use be active retail, as recommended in the Retail Refinement Plan?	No.
H)	Sustainable Building	Will the building be built using sustainable practices including LEED or others?	Not addressed in application.
I)	Residential	Is there a residential component? How many units?	Existing residential units are not directly impacted by this project.
<i>Economic Development</i>			
J)	Bring new business to Albany	Will a new business open or come to Albany as a part of this project?	No.
K)	Job Creation	Will the project create additional jobs? How many, what types and what salary level?	No.
L)	Local Labor and Materials	Has applicant specifically called out a commitment to use a certain percent or amount of local labor and/or materials?	Not specifically called out in applicaiton.
<i>Financial</i>			
M)	Ratio	Proposed public funds Private funds % of CARA Investment	Applicant requesting 75% of total project costs.
N)	Financial Impacts	What are the financial risks and/or financial benefits to CARA?	Reimbursement based-grant; low financial risk. Benefits through increased value.
O)	Gap	What is the "Gap" or need of the developer?	\$71,655
P)	Private Risk	What is the risk for the developer? What is their skin in the game?	\$23,885
Q)	CARA/City funds	Has the project received other CARA/City funding in the past?	Yes.
R)	Tax Increment ROI	Is the ROI on this project less than 5 years, less than 7 years?	ROI will be achieved through increased property value.



CARA GRANT APPLICATION

1. APPLICANT

Name: The Grove Church (James Carmichael, Pastor)

Mailing Address: 241 W 1st Ave, Albany, OR

Zip Code: 97321

Title: Lead Pastor

Phone Number: [REDACTED]

E-mail Address: [REDACTED]

2. BUSINESS/BUILDING INFORMATION

Legal Business Name: The Grove Church

Number of Years in Operation: 17

Legal Form: Sole Proprietorship Partnership Corporation S-Corp LLC
 Profit Nonprofit

EIN: [REDACTED]

In which state are the incorporation and/or organization documents filed? Oregon

Have you ever filed for bankruptcy? Yes No

Project Address (if different than mailing address): _____

Property Tax Account Number: 80925

Is the building a historic contributing resource? Yes No

If so, is it on the historic property-tax freeze? Yes No

3. OWNER OF PROPERTY (if not applicant)

Name in which title is held: The Grove Church

Contact Name: James Carmichael

Mailing Address: 241 W 1st Avenue

Zip Code: 97321

Phone Number: [REDACTED]

4. AUTHORIZATION TO UNDERTAKE WORK:

If the applicant is not the owner of the property, provide written evidence that the owner authorizes this work to be undertaken. (Typically this is in the form of a lease or other written permission.)

5. DESCRIPTION OF PROJECT *Please give a comprehensive description of project.*

Our proposed project is a complete replacement and updating of the membrane roof on the building.

This would involve removal of existing membrane, necessary repairs if needed, new insulation required by updated building codes and installation of a new membrane roof.

6. TIMELINE FOR COMPLETION OF PROJECT: Summer 2026

7. PROJECT COSTS

ESTIMATED COST OF PROJECT: \$216,000

ESTIMATED VALUE OF PROJECT UPON COMPLETION: \$216,000

Basis for valuation and value upon completion: Market building value

SOURCES FOR PROJECT:

Owner/Company Contribution \$66,000

Bank (estimated) \$

Other private funds (please specify) \$

Other governmental (please specify) \$

CARA (proposed) \$150,000

TOTAL SOURCES \$

Is your funding for these: available today applied for unknown at this time

USES FOR PROJECT:

Land and/or Building Acquisition \$

Soft Costs (architectural, engineering, financing, and legal fees, and other pre- and post-construction expenses.) * \$

Construction Costs * \$216,000

Tenant Improvements \$

Machinery/Equipment/Installation Costs \$

Working Capital \$

Other (please specify) \$

TOTAL USES \$216,000

*Please provide a detail of Soft Costs and of Construction Costs (Please attach).

8. PREPARATION OF COST ESTIMATES

Who prepared your cost estimates? 2 Roofing companies, attached.

(If applicant prepared their own estimate, verification may be required. **Please attach minimum of two bids, preferably three.**)

Mailing Address: _____

Phone Number: _____ E-mail Address: _____

9A. EXPLAIN WHY CARA FUNDING IS NECESSARY TO INSURE PROJECT COMPLETION.

(Please provide a description of the financial gap requiring CARA assistance.)

We have been planning and saving for several years for this project, as it is a major expense. It is essential that the roof be replaced for the long term preservation of the Venetian Theater.

After purchasing the building in 2020, we have done major building enhancements and upgrades. There was a major build-up of deferred maintenance left by the previous owners. Recently we replaced the two large HVAC units on the roof, which pushed us past the \$200,000 dollar mark in building improvements.

Currently, our church is in a two-year capital campaign of improvements to the building. The total for these projects will be approximately \$400,000. Improvements include the rooftop HVAC, roof replacement, historic window repairs and replacements, renovating the washrooms, exterior facade repairs, installing a kitchen and updating the theater lighting and general ambiance.

CARA funding will be timely as we are needing to replace the roof as soon as possible. We have enough cash currently to partner with CARA in this grant and additional fundraising can speed up other projects.

9B. IF YOU DON'T RECEIVE THE FUNDS, WHAT COMPONENTS WILL BE DROPPED? WOULD THE PROJECT GET DONE WITHOUT CARA FUNDS? (Please provide a detailed explanation.)

Without CARA funds, the project will definitely be delayed. The cost of a roof replacement is extraordinary and raising the funds for it takes time.

The major consequence would be the delay in the overall building improvements and other elements in our current capital campaign.

Would the project get done without CARA funds? Eventually it would, because it would have to. But we feel that CARA funding would speed up the current projects and help the theater space to be completely finished and more available for public use.

10. WHERE ELSE HAVE YOU LOOKED FOR FUNDING?

We have previously applied for Downtown Heritage grants with the help of the Albany Downtown Association.

Currently we are fundraising through The Grove Church for the overall captial campaign.

11. CONSIDERING THE PROJECT GOALS OUTLINED IN THIS APPLICATION, PLEASE IDENTIFY THE VALUE YOUR PROJECT BRINGS TO CARA.

The Grove Church is a community minded church. Our members and our program design is always with an eye for having a postivie impact in our city. Our downtown neighbors experience increased foot traffic and people driving into the downtown area as we are gathering as a church throughout the week. When we hold events we have often pushed attendees to dine at downtown restaraunts and even have provided a guide for people to use when we break for meals instead of brining in outside catering.

Further, the theater space and smaller meeting rooms in The Venetian Theater have proven useful for hosting events in the central Albany area. Last fall we were the main site for the Albany Downtown Association's annual state wide meeting. Having our large room gathering space creates the opportunity for positive events in the downtown core. Our vision for future use is to be open to the public as a large venue available to rent for conferences, staff retreats, weddings, and live music. All of this brings foot traffic into downtown.

12. PLEASE OUTLINE ANY OTHER BENEFITS YOUR PROJECT PROVIDES.

(To Albany, and the area/neighborhood)

The benefit of this project for Albany and spECIALIALLY the downtown area is two-fold. First, The Grove Church carries a reputation for being a positive member of the community. This has been built over many years of ledership and participation in our city and the many different areas that make Albany a great place to live. A major recent event in our building was providing zero-cost childcare during the GAPS techer strike. Church members volunteered and helped out local downtown families in need of crisis help. Our site was so well run, the school district was willing to use the building as a food distribution center.

Secondly, the building itself is unique in the downtown area because it has space for larger events and meetings with many local restaurants and bars within walking distance. This creates a symbiotic relationship in the center of Albany where locals and out-of-town visitors can come to our city for well run events and enjoy a positive and professionally run event. While it is true that many church spaces are empty during the week, our theater space is perfectly designed for larger events with participants in the hundreds. The updates proposed will help us become a premier space to host quality events that will draw buisness and people into downtown.

13. HAVE YOU OR THIS PROPERTY RECEIVED CARA FUNDING AT ANY POINT IN THE PAST?

No Yes If so, amount \$ _____

FOR WHAT PROJECT(S): _____

WHEN? _____

14. ASSISTANCE REQUESTED

Total Estimated Project Costs:	<u>\$ 216,000</u>
Your Total Contribution	<u>\$ 66,000</u>
Total Amount Requested from CARA:	<u>\$ 150,000</u>

Final payment will be based on actual costs not estimates. **Ten percent of CARA funds will be held back for final payment.**

15. BREAKDOWN OF USE OF CARA FUNDS

CARA funds can only be used for permanent improvements to the building. Please provide a breakout with specific details of how the CARA funds will be used in the project. If more space is needed, please attach a separate page.

Item	Amount	Notes
Roof Replacement	\$150,000	See attached estimates
TOTAL	\$150,000	Total should match total amount requested from CARA from line 14.

Metrics and Other Benefits

If you receive funding, you will be asked to tally the final figures on the project and certify their accuracy. Please use this space to estimate the impact of your project:

Number of Jobs Created: X Full-time X Part-Time

Certification

The Applicant understands and agrees to the following conditions:

1. Any physical improvements proposed must be approved by the Albany Revitalization Area Agency (ARA) and may require approval by the City of Albany Landmarks Advisory Commission or other entities. These entities may require certain changes or modifications before final approval and Commitment of Funds.
2. Any work begun before receipt of a Contract notice is ineligible for reimbursement.
3. Any work deviating from that detailed in the Contract must be preapproved in writing to be eligible for reimbursement.
4. While only proprietary information may be held in confidence outside of the public record, ARA will attempt to maintain all information provided in a confidential manner.
5. Originals of all materials prepared with ARA assistance belong to ARA and will be maintained in the public record.
6. Application must be completed in its entirety before being considered; if not, it will be returned for completion.
7. Staff is authorized to independently verify any and all information contained in this application.
8. ARA may withhold approval of this application until information satisfactory to ARA is provided.

The Applicant certifies that all information in this application and all information furnished in support of this application is given for the purpose of obtaining ARA assistance and is true and complete to the best of the Applicant’s knowledge. Applicant further acknowledges the undersigned applicant(s) have read and understand CARA’s privacy policy and have completed this form with accurate information.

James Carmichael

Applicant’s Printed Name

Applicant’s Printed Name

Applicant’s Signature **James Carmichael**

Date **30 March 2026**

Applicant’s Signature _____

Date _____

Return application/attachments to: City of Albany c/o Sophie Adams, Economic Development Manager: sophie.adams@albanyoregon.gov



- ROOFING
- SIDING
- CONSTRUCTION

CCB# 96278

1954 Rye Street SE • Albany, OR 97322

Estimator: Kurt Gates

Date: March 3, 2025

Customer: Larry Preston Remodeling and Repair	Job Address: 241 West 1st Avenue, Albany OR 97321
1152 Southwest 12th Avenue	Albany, OR 97321
Albany, OR 97321	Fax:
Mobil #: (541) 812-1144 Day#: Eve#:	Email: prestonk99@gmail.com

Scope of Work

- Tear Off Roofing layers, 3-4 Layers of PVC and Asphalt roofing
- Sweep roof clean of debris and materials
- Inspect roof for dry-rot conditions and moisture issues
- Prepare all penetrations and roof deck for installation of new roof
- Install Vapor Barrier over existing roof
- Install Insulation to meet Code and a Cover board for fire Rating
- Back Frame Existing areas to slope back towards the drains in the Center of the Roof
- Plumber to Install New Drains and Overflow drains, this is Considered Extra, it will be \$5,000- \$8,000 for this
- Mechanically attach new membrane roof (your selection listed below)
- Install proper screws and plates for correct fastening depth for wind rating requirements
- Install new pipe boots and pipe jacks as needed
- Install new Vents as needed
- Install new drip and rake metal on perimeter of roof
- Adhere walls as needed
- Heat weld all seams and penetrations for securement
- Probe and inspect final roof
- Cleanup all gutters, ground, and roof
- Permit
- 5yr Workmanship Warranty

Special Notes

The Drains need to be redone by a plumber, below is a Budget number for this extra work, the current drains are not to code and they should be cast iron drains with Rings to make a water tight seal.

****All Dry-Rot Repair or Structural Improvements Will Be Billed As Time (\$90 Per Man Hour) and Material (with 45% Handling Fee)****

Includes: Rafters, Soffit Panels, Fascia Boards, T&G Decking, Ventilation Enhancements

****Additional 1/2" Plywood Will Be Billed At Market Value, Handling, Markup, & Time Per Sheet for Roof Deck/Field Replacement****

****A fuel surcharge will be assessed based on the date of installation. Surcharge will be based on a range depending on the distance from our office location in Albany, OR. The greater the distance from the home office to your location, the greater the surcharge will be. Per Vehicle Cost/ Per Day- Range (\$15-\$40)****

****Not Included: Touch Up Trim Paint on Gables, Fascia, Chimneys, Fascia Plywood, Gutters, Back Pans, Satellite Dish Alignment, New Skylights Unless Specified In Contract, Etc...****

****All repairs not specifically noted are charged as time and materials (plus 45% on material handling.) If possible, we will notify you before we do those repairs.****

Product Choices	Price	Acceptance
Estimate Mar 3, 2025		Accept ____ Decline ____
60mil TPO Roof System with a 20yr Material Warranty	\$142,848.00	Accept ____ Decline ____
60mil PVC Roof System with a 20yr Material Warranty, this is what you have	\$146,765.00	Accept ____ Decline ____
		Accept ____ Decline ____

<u>Recommended Options</u>		<u>Price</u>	<u>Acceptance</u>
1: Plumber to Install new Drains and Overflow Drains	Budget	\$5,000-\$8,000	Accept ____ Decline ____
2: If Boli Wages Apply	ADD	\$36,000.00	Accept ____ Decline ____
3		\$	Accept ____ Decline ____
4		\$	Accept ____ Decline ____

Color:	Total Price:

Dear Valued Customer,

We at Stutzman and Kropf Contractors Inc. would like to take a few moments to explain our different roof systems and warranties that we offer to our customers and what you can expect from Stutzman and Kropf Contractors Inc. Although roofing projects vary in some degree, Stutzman and Kropf Contractors Inc. performs the following procedures on most residential roof applications which exceed the roofing standards set by the building codes and manufacturers.

- Tear off all existing materials and dispose of all debris and prepare roof deck which may include installation of plywood. Please note: Roof decks without plywood may void part or all of manufacturers wind and labor warranty.
- Install ASTM felt, Shingles, Hip and Ridge, Ice and water shield around chimney and skylights.
- Install roofing accessories, which may include brown drip metal and/or rake metal if needed.
- New pipe jacks, gray, brown or black roof vents, painted flashings around the base of chimneys and skylights.
- Extensive cleanup, which includes cleaning out gutters and raking of flower beds and use of magnet for picking up nails. Sweeping concrete driveways and sidewalks with the utmost care taken to minimize damage to shrubbery and flower beds.
- We will check your gas ventilation ducts to your furnace and hot water heater to make sure they are properly attached after the roof is completed (If you are home when the roofing crew is done).
- As a convenience to our customers and employees, we usually tow our portable restroom to the job site each day.
- In most cases, we will complete your job in one day and includes a written workmanship warranty in addition to the manufactures warranty that will be mailed to you after the job is **paid in full**.
- Because we need to access your roof from the driveway, any vehicles that you may need during the day need to be out of the garage and driveway before we arrive. We recommend that you have your cars out of the garage and driveway during the roofing process, as we want to eliminate the possibility of any damage occurring.

****Ventilation & Design Considerations****

- We are not design engineers, all condensation or ventilation considerations is the owners responsibility to choose the best course of action prior to or before installation begins.
- All single ply membrane re-roof systems and new require a recommended level of R19 insulation value to reduce risk of condensation and sweating.
- Vaulted ceilings ventilation is recommended to pull off all plywood and ensure proper cavity spacing for ventilation exists. Owners are responsible to understand this consideration to do this before installation process or assume risk of potential ventilation failures.
- All new skylight installations include work above the roof deck only. Any interior finish work is responsibility of the homeowner, unless specified in contract.
- All hidden conduit lines beneath the visible sub sheathing on the roof and exterior walls are the responsibility of the homeowner to repair if damaged during installation process. Buried power lines, plumbing pipers, and other contractor trades behind sub-sheathing will need to be repaired by professional tradesman.

Initial Acknowledgment:

The following are some suggestions for you as a home owner to be prepared for us when we arrive to roof your home.

- You may want to remove any pictures or other valuables from your walls that could vibrate off your walls and shelves. Although this is not normally a problem, items could fall and be damaged. Stutzman and Kropf Contractors Inc. will not be responsible for losses of this kind.
- Stutzman and Kropf Contractors Inc. will reinstall satellite dishes and antennas, however it is the responsibility of the customer to schedule and pay for any adjustments needed after the roof is completed.
- We recommend that you check any light fixture globes before and after the roof is completed to make sure they are not loose. Smoke detectors should also be checked that they are working properly at this time.
- You may want to cover stored items in your attic/any unfinished garage or shop to protect them from dust and debris.
- Shake and wood shingle removals leave small debris and particles in attic spaces. We will do our best to minimize debris in attic space, but not accountable to remove it from attic space or clean insulation.
- Stutzman & Kropf Contractors uses heavy equipment like Scissor Lift Semis, Dump Trucks, Crew Trucks, Dump Trailer, etc., and will not be responsible for cracks, sinking, or chipping of existing concrete or asphalt driveways.

Contractors:

Terms are net 10th of the month on work completed in the previous month.

Late charges of 4% of balance not paid by the 15th will be added to total.

By signing the Contract, I acknowledge that I have received and read the sheet which contains the consumer notices required by the State of Oregon. I

acknowledge and accept the terms and conditions of payment options of the contract. We at Stutzman and Kropf are dedicated to giving you top quality service, materials and workmanship. Please feel free to contact us if you have any questions about your new roof or the installation process. Thank you for considering Stutzman and Kropf Contractors Inc. for roofing needs. **To move forward, we need the signed and initialed contracts mailed, emailed, or faxed directly to our office. Upon receipt of your signed contract, we will call you to schedule your upcoming project. All projects are done in the order that they are received by our office.**

241 W 1st Ave

Cards:

Visa, MasterCard credit cards, and Debit Cards are gladly accepted; however 4% will be added to the total invoice at the time of payment. All other payment arrangements must be made and approved by Stutzman and Kropf Contractors Inc. before the job is started.

Initial Acknowledgment:

Payment Terms: Due upon job completion

- Payment is due in full when Job is completed, unless otherwise specified in contract/proposal.
- Late charges of 4% of balance may be added if not paid within 5 days of completion.
- See front of contract for down payment instructions (if required)
- We prefer Bank, Business and Personal checks.
- Multi day projects **will require a 30% down payment** prior to the beginning of the job.
- By signing the Contract, I acknowledge that I have received and read the green sheet which contains the consumer notices required by the State of Oregon.
- I acknowledge and accept the terms and conditions of payment options of the contract.

Initial Acknowledgment:

Estimator Signature: Kurt Gates

Estimate expires 30 days past the proposal date

Customer Signature: _____

Date: _____



Taking Care of Your Roof and Everything Underneath it!

BID PROPOSAL NO. JC022625

1645 9th Ave. SE, Ste. 323
Albany, Oregon 97322

Oregon CCB No. 201381
WA Lic. No. OREZOBR825LQ

Owner's Name: James Carmichael	Owner's Address: 241 W 1 st Ave	
Owner's City, State, Zip: Albany Oregon, 97321	Owner's Phone: [REDACTED]	Owner's Alt. Phone: [REDACTED]
Project Name & Address:		Email: [REDACTED]

A. Scope of Work: Orezona Building & Roofing Co., Inc. hereby submits the following specifications and estimates:

Remove all existing 3 Layers of roofing on Top & Bottom Elevation, haul away debris, and inspect for rotten/loose plywood

Provide and Install:

- 2 Layers of 2.6" **Rigid Foam Insulation** (Commercial R-30 Value)
- **GAF Versashield Solo Class A Fire Rated Slip Sheet**
- **GAF Everguard 60 Mil TPO**- mechanically fastened and heat welded on low slope, parapet walls fully adhered
- **New Prefabricated Scuppers, Drains & Overflow(s)**
- **New TPO Breather Vents**
- **New Pipe Flashing** - clamped and sealed
- **TPO Membrane Accessories**
- **Re-use Existing Cap Metal Around Perimeter** - replace as needed
- **10 Year Workmanship Warranty**

Note: Any/All HVAC or Electrical work will be performed by a licensed contractor, prices will be passed directly to customer.

Roof decking replacement (plywood etc) is billed at \$75 per sheet which includes labor and materials. Structural repairs below the sheathing (e.g. rafters, fascia boards, etc) are billed on a T&M basis at \$70 per man hour plus material costs (30% Handling added). Due to the State of Oregon's new "corporate activity tax" a ½ % of your invoice total will be added to your final invoice.

B. Not Included: This proposal does not include: Anything other then stated.

C. Roofing Material Warranty: Limited Life time Warranty- Residential, 20 Year Limited Warranty Commercial

D. Terms of Payment: PAYMENT IS DUE UPON COMPLETION UNLESS ALTERNATE ARRANGEMENTS HAVE BEEN MADE. After 30 days of nonpayment, a finance charge will be assessed on all outstanding balances. If Orezona Bldg & Roofing Co. INC elects to affirm this contract and collection of any amount due is placed in the hands of an attorney for collection, purchaser promises to pay Orezona Bldg & Roofing Co. INC reasonable attorney's fees and collection costs even though no suit is filed or action take heron; if a suit or action is filed the amount of such attorney's fees fixed by the court or courts in which the action, including any appeals therein, is tried, heard, or decided. The purchaser agrees to arbitration before any suit or action is filed. Any alteration from the above specifications involving extra cost will be executed only upon written orders, and will become an extra charge over and above the bid proposal amount. All agreements are contingent upon strikes, accidents, or delays beyond our control.

Payment Schedule:

E. WE PROPOSE to furnish material, equipment and labor in accordance with the above specifications for the sum of:

\$215,775.00 dollars

NOTE: This proposal may be withdrawn if not accepted within 30 days from 2/26/2025 date

Respectfully submitted by: Johnathan Sole
Company Representative

F. ACCEPTANCE OF PURCHASE: I acknowledge terms of payment and Notice of Right to Lien. The above prices, specifications, and conditions are hereby accepted. You are authorized to do work as specified as above.

approved and accepted (owner or owner's authorized agent) date

approved and accepted (second owner - if any) date



Project Evaluation Grid: 241 W First Avenue

Request: \$150,000

	Item	Description	Staff Analysis/Comments
<i>Overall Goals</i>			
A)	<p>CARA Goal & Objectives: The purpose of this CARA Plan is to eliminate blighting influences found in the CARA, to implement goals and objectives of the City of Albany Comprehensive Plan, and to implement development strategies and objectives for the CARA. The goal and objectives for the CARA have been defined as follows:</p> <p>CARA Goal: To revitalize the Central Albany Revitalization Area by implementing the Town Center Plan developed through the Central Albany Land Use & Transportation Study (CALUTS) using a citizen-driven process.</p>	<p>Does the project further the Town Center Plan?</p> <p>Which of CARA's objectives does the project meet?</p> <p>CARA Key Objectives:</p> <ul style="list-style-type: none"> ◆ Attract new private investment to the area. ◆ Retain and enhance the value of existing private investment and public investment in the area. <p>CARA Additional Objectives:</p> <ul style="list-style-type: none"> ◆ Provide a safe and convenient transportation network that encourages pedestrian & bicycle access to and within the town center. ◆ Preserve the Historic Districts, historic resources and existing housing in the area. ◆ Create a readily identifiable core that is unique and vibrant with a mixture of entertainment, housing, specialty shops, offices, and other commercial uses. ◆ Increase residential density in the area. ◆ Encourage the development of new forms of housing and home ownership. ◆ Enhance and protect the community and environmental values of waterway corridors in the area. ◆ Provide an enriching environment and livable neighborhoods. 	<p>Yes.</p> <p>This project meets CARA's two key objectives as listed.</p> <p>Additional objectives met:</p> <p>Historic preservation Readily identifiable core Enriching environment</p>
B)	CARA Planned Projects	Which project category and activity in the UR Plan does this project fulfill? (See CARA Project Activities document, or Table 2 of the UR Plan and Report.)	Commercial Building Rehabilitation
C)	Development Pattern (Highest and Best Use)	Does it achieve desired land use (e.g., mixed-use, higher density) and/or transportation objectives (e.g., Esplanade, pedestrian-friendly areas)? Is the proposed project desired in this location and the highest and best use of the property?	Zone: Historic Downtown Planned event space elevate this project to fall within highest and best use options for the property.
D)	Blight	Would it remedy a severely blighted building? How? Does the project utilize a vacant space?	No.

E)	Preservation	Would it rehabilitate or sensitively redevelop a historic property?	Yes.
F)	Vitality/People Attractor	Does the general public benefit (i.e. restaurant, carousel, something they can go to; does the project enhance the public's experience of the space; is it a business we are seeking)?	Yes, the Venetian Theater is utilized as an event space.
G)	Retail Hotspot (First Avenue between Lyon and Calapooia)	Is the project located in the Retail Hotspot? If so, will the first floor use be active retail, as recommended in the Retail Refinement Plan?	Yes. No, not active retail use.
H)	Sustainable Building	Will the building be built using sustainable practices including LEED or others?	Not addressed in application.
I)	Residential	Is there a residential component? How many units?	No.
<i>Economic Development</i>			
J)	Bring new business to Albany	Will a new business open or come to Albany as a part of this project?	No.
K)	Job Creation	Will the project create additional jobs? How many, what types and what salary level?	No.
L)	Local Labor and Materials	Has applicant specifically called out a commitment to use a certain percent or amount of local labor and/or materials?	Not specifically called out in application.
<i>Financial</i>			
M)	Ratio	Proposed public funds Private funds % of CARA Investment	Applicant requesting 69% of total project costs.
N)	Financial Impacts	What are the financial risks and/or financial benefits to CARA?	Reimbursement based-grant; low financial risk. Benefits through increased value.
O)	Gap	What is the "Gap" or need of the developer?	\$150,000
P)	Private Risk	What is the risk for the developer? What is their skin in the game?	\$66,000 for this phase of the project.
Q)	CARA/City funds	Has the project received other CARA/City funding in the past?	No.
R)	Tax Increment ROI	Is the ROI on this project less than 5 years, less than 7 years?	Due to non-profit status, ROI from tax-increment is not imminent.



CARA GRANT APPLICATION

1. APPLICANT

Name: Jim and Corina Abbott

Mailing Address: [REDACTED]

Zip Code: _____

Title: Owners Phone Number: [REDACTED]

E-mail Address: [REDACTED]

2. BUSINESS/BUILDING INFORMATION

Legal Business Name: Heart of the Valley Property, LLC. (a division of Polynovation, LLC.)

Number of Years in Operation: 4

Legal Form: Sole Proprietorship Partnership Corporation S-Corp LLC
 Profit Nonprofit

EIN: [REDACTED]

In which state are the incorporation and/or organization documents filed? Oregon

Have you ever filed for bankruptcy? Yes No

Project Address (if different than mailing address): 333 1st Ave. W. Albany, OR 97321

Property Tax Account Number: 80818

Is the building a historic contributing resource? Yes No

If so, is it on the historic property-tax freeze? Yes No

3. OWNER OF PROPERTY (if not applicant)

Name in which title is held: _____

Contact Name: _____

Mailing Address: _____

Zip Code: _____

Phone Number: _____

4. AUTHORIZATION TO UNDERTAKE WORK:

If the applicant is not the owner of the property, provide written evidence that the owner authorizes this work to be undertaken. (Typically this is in the form of a lease or other written permission.)

5. DESCRIPTION OF PROJECT *Please give a comprehensive description of project.*

Please see description in the attached document

6. TIMELINE FOR COMPLETION OF PROJECT: Summer of 2026

7. PROJECT COSTS

ESTIMATED COST OF PROJECT: \$ 375,142.95

ESTIMATED VALUE OF PROJECT UPON COMPLETION: \$ 1.3M

Basis for valuation and value upon completion: The valuation is based on an 8% cap rate and the contracted and estimated rental rates of the units based on current market analysis.

SOURCES FOR PROJECT:

Owner/Company Contribution	<u>\$ 63,785.74</u>
Bank (estimated)	<u>\$ 30,000</u>
Other private funds (please specify)	<u>\$ _____</u>
Other governmental (please specify)	<u>\$ _____</u>
CARA (proposed)	<u>\$ 281,357.21</u>
TOTAL SOURCES	<u>\$ 375,142.95</u>

Is your funding for these: available today applied for unknown at this time

USES FOR PROJECT:

Land and/or Building Acquisition	<u>\$ 0</u>
Soft Costs (architectural, engineering, financing, and legal fees, and other pre- and post-construction expenses.) *	<u>\$ 0</u>
Construction Costs *	<u>\$ 375,142.95</u>
Tenant Improvements	<u>\$ 0</u>
Machinery/Equipment/Installation Costs	<u>\$ 0</u>
Working Capital	<u>\$ 0</u>
Other (please specify)	<u>\$ 0</u>
TOTAL USES	<u>\$ 375,142.95</u>

*Please provide a detail of Soft Costs and of Construction Costs (Please attach).

8. PREPARATION OF COST ESTIMATES

Who prepared your cost estimates? Knox Construction, other subcontractors, and owners.

(If applicant prepared their own estimate, verification may be required. **Please attach minimum of two bids, preferably three.**)

Mailing Address: [REDACTED]

Phone Number: [REDACTED]

9A. EXPLAIN WHY CARA FUNDING IS NECESSARY TO INSURE PROJECT COMPLETION.

(Please provide a description of the financial gap requiring CARA assistance.)

Please see included document.

9B. IF YOU DON'T RECEIVE THE FUNDS, WHAT COMPONENTS WILL BE DROPPED? WOULD THE PROJECT GET DONE WITHOUT CARA FUNDS? *(Please provide a detailed explanation.)*

Please see included document.

10. WHERE ELSE HAVE YOU LOOKED FOR FUNDING?

Please see included document.

11. CONSIDERING THE PROJECT GOALS OUTLINED IN THIS APPLICATION, PLEASE IDENTIFY THE VALUE YOUR PROJECT BRINGS TO CARA.

Please see included document.

12. PLEASE OUTLINE ANY OTHER BENEFITS YOUR PROJECT PROVIDES.

(To Albany, and the area/neighborhood)

Please see included document.

13. HAVE YOU OR THIS PROPERTY RECEIVED CARA FUNDING AT ANY POINT IN THE PAST?

No Yes If so, amount \$ _____

FOR WHAT PROJECT(S): _____

WHEN? _____

14. ASSISTANCE REQUESTED

Total Estimated Project Costs:	\$ <u>375,142.95</u>
Your Total Contribution	\$ <u>93,785.74</u>
Total Amount Requested from CARA:	\$ <u>281,357.21</u>

Final payment will be based on actual costs not estimates. **Ten percent of CARA funds will be held back for final payment.**

15. BREAKDOWN OF USE OF CARA FUNDS

CARA funds can only be used for permanent improvements to the building. Please provide a breakout with specific details of how the CARA funds will be used in the project. If more space is needed, please attach a separate page.

Item	Amount	Notes
Please see the attached document		Briggs_Albany_CARA_Budget_2026.pdf
TOTAL	\$281,357.21	Total should match total amount requested from CARA from line 14.

Metrics and Other Benefits

If you receive funding, you will be asked to tally the final figures on the project and certify their accuracy. Please use this space to estimate the impact of your project:

Number of Jobs Created: 1-2 Full-time _____ Part-Time

CARA GRANT APPLICATION WRITTEN SECTIONS

5. Description of the Project

Renovating the Historic 1875 John Briggs building is a large, comprehensive project that began 4 years ago when we purchased the property with the intention of saving it. This historic wood structure was originally completed in September of 1875 by John Briggs. This is the oldest wooden structure still standing in the commercial district of historic downtown. Our goal has been to reverse the damage caused to the building over the last 150 years by the elements, incorrect modifications to the property, and deferred maintenance – honoring its original design and bringing it into a healthy condition that will last for the next 150 years.

Up to this point we have corrected the majority of the structural issues that have arisen from rot damage, fire, and bat infestations. We literally started at the ground with lifting the building and completely reconstructing the building's foundation. For the purpose of this grant money, we are seeking assistance to complete the finishing details of the project.

These details include the installation of the required sprinkler system, completion of the electrical including the fixtures required for the incoming retail tenant, drywall throughout to complete the space and provide fire wall protection, interior and exterior painting, installation of the reclaimed historic flooring and period relevant flooring, the decorative cornice at the top of the building, repairs and protection of the historic brick wall that pre-dates the 1875 John Briggs building (older than 150 years), and the awnings for the front and back of the building.

9A. Explain Why CARA Funding is Necessary to Insure Project Completion

Heart of the Valley Property has invested a total of about \$1,000,000 into this project including the building purchase price. Our funding sources have included a private loan, a \$200,000 Main Street Grant from the State of Oregon, a private party grant, and owners' equity. Heart of the Valley Property has about \$60,000 of capital left available for the completion of this project – the majority of this capital is earmarked for finishing the siding and historic window restoration that are currently in process. The owners of the company have already contributed a majority of their available capital for investment to this project. Owners are also seeking a Home Equity Line of Credit on their personal residence to help with cash flow. While other options are being explored, no additional resources are available at this time.

Materials and construction costs have risen sharply since the inception of this project. We have already spent more than the original estimate provided to us in 2023 and more work is needed to bring the space into community service. The steep rise in costs is not something any of us can control, but is an obstacle we are working to mitigate by applying for grant funding.

9B. If You Don't Receive the Funds, What Components Will Be Dropped? Would the Project Get Done Without CARA Funds?

The components that we have proposed in this grant application are required to get the building ready for occupancy. We will continue to pursue the means to complete the project as we are already heavily invested. To protect this investment, it is crucial to bring the building into full service, making the apartment spaces ready to be tenants' homes, and making the retail space available for our commercial tenant to bring their vision of an interior design show room to life. To bring this project to full completion, if necessary we will examine adding additional debt and other sources of capital to the project, but this will delay our ability to have it ready to occupy and serve our community. Grant funding from CARA would help us get to completion this summer.

The expected value of the building after completion based on an 8% cap rate is about \$1.3M. There is a risk that the cost of the entire project will be more than the final valuation. Without help from CARA, there is the possibility that the work we have put into this project over the last 4 years will still result in a financial loss for Heart of the Valley Property.

10. Where Else Have You Looked For Funding?

So far in this project we have obtained a private loan, been awarded a Main Street Grant from the State of Oregon, received a private party grant, and have used large amounts of owners' equity to fund this project.

11. Considering The Project Goals Outlined In This Application, Please Identify The Value Your Project Brings to CARA.

When we purchased the John Briggs building in 2022 it was the most dilapidated building in the commercial core on 1st Ave. As we have been rehabilitating the building we have found and repaired damage from at least 4 fires, replaced support structures that were completely rotten, and have added an engineered foundation and support solutions to make the building more stable than it has ever been. We have also begun the work of restoring the historic style of the building. When complete, the historic building will provide a Class A retail space on 1st Ave. with its historic character restored and will add 4 dwelling units to the Albany housing market.

The monies requested from CARA will aid in the completion of the building and help accelerate making this space available to our community.

12. Please Outline Any Other Benefits Your Project Provides.

Renovating a dilapidated building has been estimated to increase the surrounding property values by as much as 5-15%. This creates a positive domino effect in the entire district by increasing the ability of neighboring owners to attract business and residential customers, and enabling owners to have access to additional debt capital, which is based on property value.

Enabling property owners' access to additional capital enables them to take on their own maintenance and renovation projects, which in turn continues to improve property values. This upward spiral of economic benefit to our community also generates economic benefit to the city from tax revenues on higher value properties.

Proposed CARA Budget for 1875 Briggs Building

Purpose Renovation

Deliverable		Estimated Cost
Interior		
Sprinkler System		\$ 48,075.50
Dry Wall		\$ 73,150.00
Paint		\$ 26,400.00
Cabinets		\$ 19,927.00
Counter Tops		\$ 12,365.00
Finish Carpentry		\$ 18,500.00
Electrical Finish & Fixtures		\$ 63,390.00
Additional Water for Sprinklers		\$ 14,245.00
Flooring		\$ 48,620.00
Insulation		\$ 13,145
Brick Wall Repair and Ceiling Hanger System		\$ 2,913
Exterior		
Paint		\$ 8,800.00
Decorative Cornice	Decorative Elements	\$ 3,500.00
	Framing	\$ 3,000.00
Juliet Balcony Safety Rails with Installation (back of building)		\$ 2,163.90
Awning - front and back		\$ 5,949.00
General		
100 hrs @ \$90/hr	Project Management	\$ 9,000.00
	Waste	\$ 2,000.00
	Total	\$ 375,142.95
Requested for Grant		\$ 281,357.21
Applicant Contribution		\$ 93,785.74

Certification

The Applicant understands and agrees to the following conditions:

1. Any physical improvements proposed must be approved by the Albany Revitalization Area Agency (ARA) and may require approval by the City of Albany Landmarks Advisory Commission or other entities. These entities may require certain changes or modifications before final approval and Commitment of Funds.
2. Any work begun before receipt of a Contract notice is ineligible for reimbursement.
3. Any work deviating from that detailed in the Contract must be preapproved in writing to be eligible for reimbursement.
4. While only proprietary information may be held in confidence outside of the public record, ARA will attempt to maintain all information provided in a confidential manner.
5. Originals of all materials prepared with ARA assistance belong to ARA and will be maintained in the public record.
6. Application must be completed in its entirety before being considered; if not, it will be returned for completion.
7. Staff is authorized to independently verify any and all information contained in this application.
8. ARA may withhold approval of this application until information satisfactory to ARA is provided.

The Applicant certifies that all information in this application and all information furnished in support of this application is given for the purpose of obtaining ARA assistance and is true and complete to the best of the Applicant's knowledge. Applicant further acknowledges the undersigned applicant(s) have read and understand CARA's privacy policy and have completed this form with accurate information.

James E. Abbott _____

Corina M. Ch. Abbott _____

Applicant's Printed Name

Applicant's Printed Name

Applicant's Signature



Date 31 MAR 2026

Applicant's Signature

Date 31 MAR 2026

Return application/attachments to: City of Albany c/o Sophie Adams, Economic Development Manager: sophie.adams@albanyoregon.gov

Briggs Building Background and Looking Forward

Prepared by
Jim and Corina Abbott
Heart of the Valley Property, LLC.
March 2026



BRIGGS BUILDING

Outline

- Before to Current
- Stabilize the Structure - What Did All of That Water Do?
- What About the Bats?
- Historic Window Refurbishment
- From Downtown Blight to Downtown Gem

Before and Current

- The images to the right show the building before the project began and where it is at currently.
- The first story of the historic building has been rebuilt. It is now ready for the finish trim.
- The shell of the addition is largely complete.

Before



Current

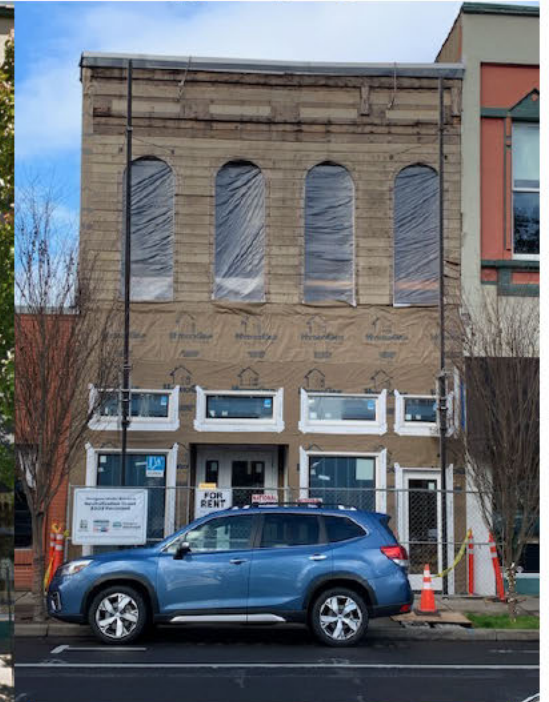

333 1st Ave W



Stabilize Structure – A Recent Example

- Stabilizing the structure was the #1 goal of this project.
- There was no support from the first story front of the building for the upper story.
- The west side of the building was found to be leaning on the adjacent structure.
- This was completely removed and rebuilt.
- The historic building will now be maintainable for the next 150 years.



Bats – Clean Up

- We discovered a large amount of bat guano from a resident bat population. We estimate removal of about 200lbs of waste.
- When the area was exposed, the bats left.
- When the roof was replaced we were able to properly seal the attic so that they cannot return.
- After cleaning the refuse from the building we have contracted for ozone disinfecting and odor removal of the area.

Waste on Floor Having Fallen from Ceiling



Waste compacted into the Wall Originally Behind Insulation





Window Refurbishment

- We are working with Chris Gustafson in Albany, Oregon on refurbishing the historic windows.
- He is using traditional building methods and will be painting the historic wood frames with a linseed Oil Based Paint.

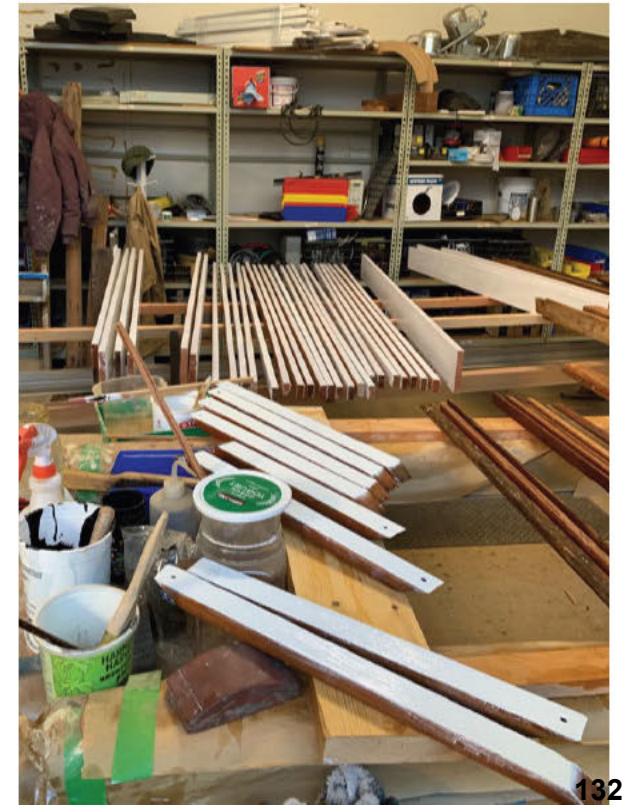

From Downtown Blight to Downtown Gem

- The 1875 John Briggs building is in transformation to become a class A property.
- This transformation while maintaining the historic character is expensive.
 - More than \$1,045,000 has been spent on this transformation project to date including acquisition of the property.
 - Materials and construction costs have risen sharply since the inception of this project. We have already spent more than the original estimate provided to us in 2023 and more work is needed to bring the space into community service. The steep rise in costs is not something any of us can control, but is an obstacle we are working to mitigate by applying for grant funding.
 - The expected value of the building after completion based on an 8% cap rate is about \$1.3M. There is a strong risk that the cost of the project will be more than the final valuation.
- We hope that CARA will join with us to help complete this project creating a beautiful historic experience for downtown Albany while also helping balance the financial risk Heart of the Valley Property has taken on with this project.
- Thank you for reviewing this application and for caring for Historic Downtown Albany.



HEART OF THE VALLEY
PROPERTY

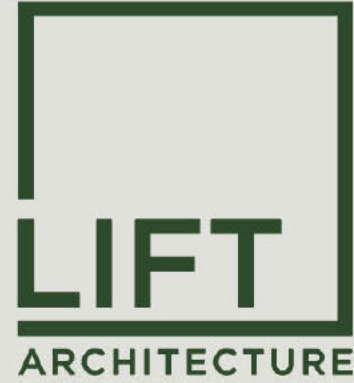

SITE AERIAL IMAGE:

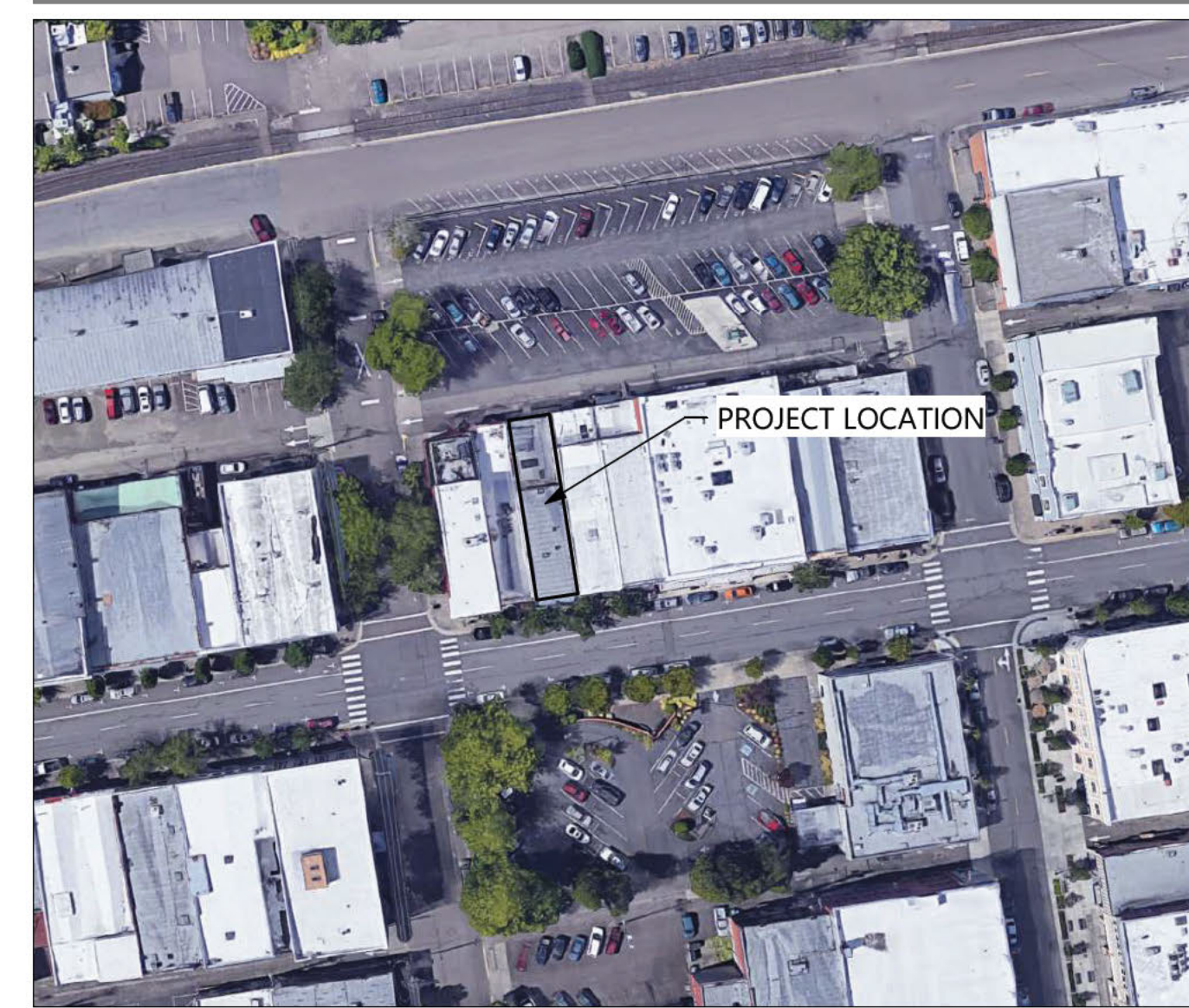

SITE VICINITY MAP:

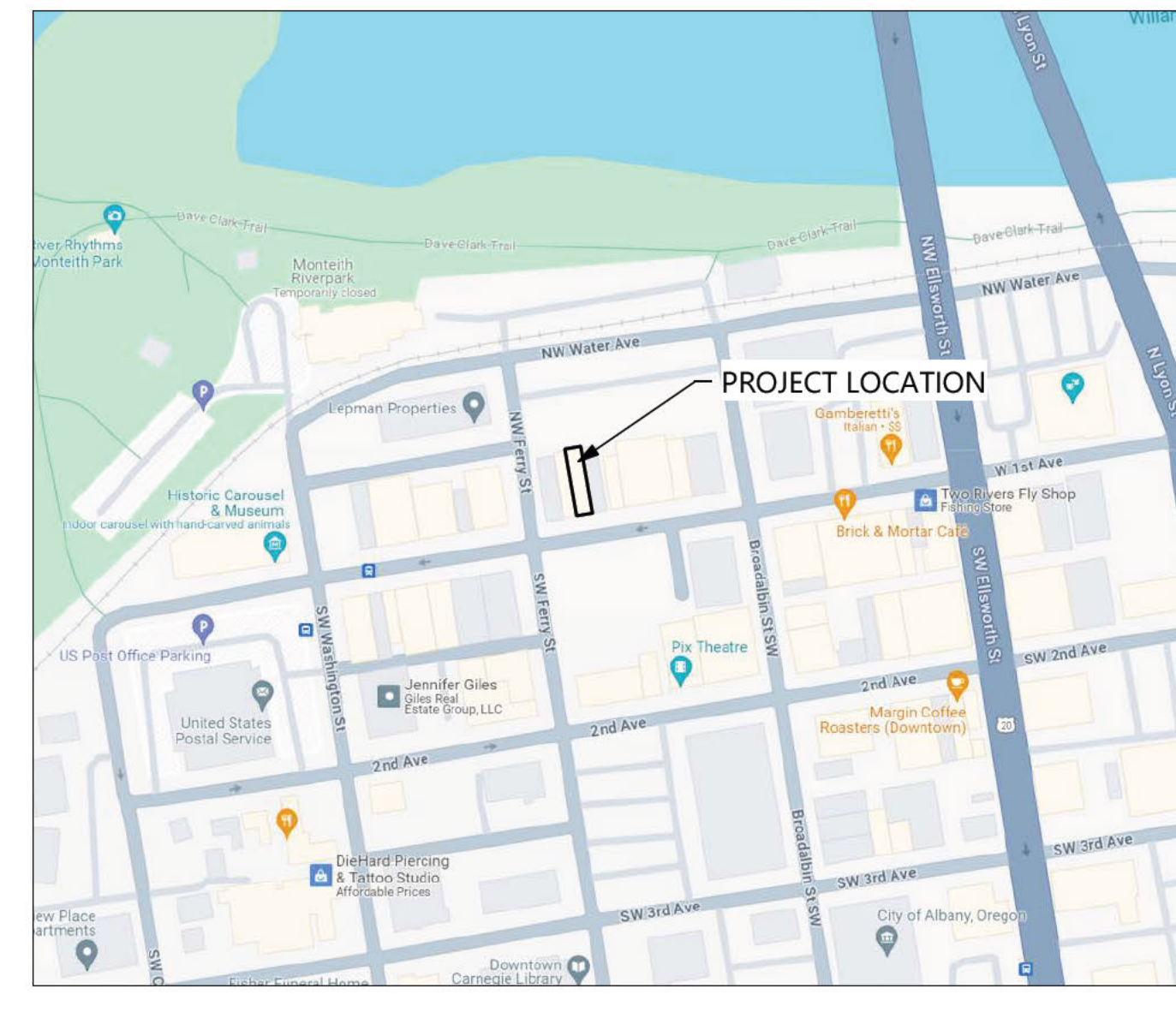

SYMBOL LEGEND:

ELEVATION DATUM:
 100.00 F.F.E. ELEVATION DATUM LOCATION

SECTION REFERENCE:
 FILLED ARROW DENOTES BUILDING SECTION
 OPEN ARROW DENOTES WALL SECTION/DETAIL
 DETAIL NUMBER

ELEVATION REFERENCE:
 ELEVATION NUMBER OR DESIGNATION AS OCCURS
 SHEET NUMBER

DETAIL REFERENCE:
 DETAIL NUMBER
 SHEET NUMBER
 SIDE NOTE IF REQUIRED
 DETAIL CUT LOCATION IF SHOWN

WINDOW TYPE:
 REFER TO WINDOW ELEVATIONS SHOWN ON DRAWINGS A5.1X

DOOR NUMBER:
 DOOR SIZE OR NUMBER

PLAN NOTE DESIGNATION:
 PLAN OR SIDE NOTE NUMBER
 MARK OR DIAGONAL NOTE NUMBER
 REVISION NUMBER

ROOM TITLE + NUMBER:
 XXXX ROOM NUMBER
 XXXX ROOM NUMBER

WALL TYPE MARK:
 WALL OR PARTITION CONSTRUCTION TYPE. SEE LEGEND.

ADDITION & REMODEL BRIGGS BUILDING

333 W 1ST AVE ALBANY OR, 97321

DRAWINGS LIST:

Sheet Number	Sheet Name	Current Revision	Revision Description
GENERAL DRAWINGS			
G0.01	COVER SHEET		
G0.02	GENERAL NOTES		
G1.01	CODE REVIEW PLANS	4	Sprinklers/Elevations
ARCHITECTURAL DRAWINGS			
A0.21	VERTICAL ASSEMBLIES		
A0.22	HORIZONTAL ASSEMBLIES		
A1.21	LEVEL 01 - FLOOR PLAN	3	Match Ex. Cond.
A1.22	LEVEL 02 - FLOOR PLAN	3	Match Ex. Cond.
A1.23	LEVEL 03 - FLOOR PLAN	1	Rear Elevation
A1.24	ROOF PLAN		
A1.61	LEVEL 01 - REFLECTED CEILING PLAN		
A1.62	LEVEL 02 - REFLECTED CEILING PLAN		
A1.63	LEVEL 03 - REFLECTED CEILING PLAN		
A2.11	PROPOSED ELEVATIONS	4	Sprinklers/Elevations
A2.51	KITCHEN ELEVATIONS		
A2.52	BATHROOM ELEVATIONS		
A2.53	RESTROOM ELEVATIONS		
A3.01	BUILDING SECTIONS	1	Rear Elevation
A3.02	BUILDING SECTIONS	3	Match Ex. Cond.
A4.11	DETAIL STAIR PLANS	2	Plan Review
A4.12	DETAIL STAIR PLANS	2	Plan Review
A5.21	EXTERIOR DETAILS		
A5.22	EXTERIOR DETAILS	1	Rear Elevation
A5.41	INTERIOR DETAILS		
A6.01	SCHEDULES	1	Rear Elevation
STRUCTURAL DRAWINGS			
S0	FIRST FLOOR REPAIR/SECOND FLOOR REPAIR		
S1	FOUNDATION/NEW FIRST FLOOR PLAN		
S2	2ND FLOOR/3RD FLOOR/LATERAL COMPLIANCE		
S3	CROSS SECTIONS		
S4	CONSTRUCTION DETAILS		

PROJECT TEAM:

OWNER:
 Heart of the Valley Properties
 Jim Abbott
 1237 NW Scenic Dr. Albany OR 97321

ARCHITECT:
 LIFT Architecture
 Matt Johnson, AIA
 1130 Liberty St SE #230
 Salem, OR 97302

PROJECT DESCRIPTION:

RENOVATION OF THE FRONT FACADE TO RESTORE THE BUILDING'S ORIGINAL HISTORICAL DESIGN, REPAIRS TO THE FOUNDATION AND STRUCTURAL COMPONENTS, REMOVAL OF THE NON-HISTORIC REAR ADDITION, AND CONSTRUCTION OF A REAR ADDITION THAT COMPLEMENTS THE HISTORIC STRUCTURE.



ADDITION & REMODEL
BRIGGS BUILDING
333 W 1ST AVE ALBANY OR. 97321

REVISIONS:

SHEET:
G0.01
COVER SHEET

PROJECT # 2024-014
DATE: 3/4/2025

GENERAL NOTES:

- General notes apply to all drawings.
- All construction shall comply with the current edition of the Oregon Structural Specialty Code and the current edition of the Oregon Fire Code where it has jurisdiction in new construction. Construction shall comply with any titles/rules/laws the local jurisdiction enforces up to and including the current edition of the Oregon Structural Specialty Code. Accessibility shall comply with the ANSI/ICC A117.1.
- Contractor or its subcontractors shall be responsible for obtaining and paying for all inspections and tests required by any government agency to implement the plans and accept any required special inspections or reports, which shall be paid for by the owner.
- Work shown on these drawings is to be supplied, furnished, constructed, installed all as per the general conditions and the specifications: exceptions as described by the following abbreviations:
 - CFCI Contractor Furnished - Contractor Installed
 - OFCI Owner Furnished - Contractor Installed
 - FOFI Owner Furnished - Owner Installed
 - NIC OR N.I.C. Not in contract or not a part of this contract.
- Do not scale drawings, dimensions govern. The general contractor shall notify the architect of any discrepancies immediately. All dimensions are to face of stud or concrete, unless otherwise noted, those indicated as clear shall be from finish.
- These drawings have been assembled for use at their current size and scale. The contractor assumes all responsibility for work not conforming to these documents due to the use of reduced scale drawings for estimating or construction purposes.
- Where construction details are not shown or noted for any part of the work, the work shall be executed consistent with the intent demonstrated by details provided for other work. If questions remain about intent, contact the architect prior to proceeding with the work.
- All surfaces and materials shall be thoroughly prepared smooth, clean, level and even. By commencing finish installation, the finish contractor signifies its acceptance of the substrate and thereby assumes responsibility for the quality of the installation.
- Where devices or items or parts thereof are referred to in singular, it is intended that such shall apply to as many such devices, items, or parts as are required to properly complete the work.
- The contractor shall layout the work prior to proceeding. The contractor shall notify the architect of all discrepancies with the layout. Such inspection shall not relieve the contractor of responsibility to conform to the intent of the contract documents.
- Unless otherwise noted, dimensions, placements and alignments shown are critical for the installation of furniture and equipment as well as for the use of the space by occupants. Finished dimensions may vary upward by ¼" but may not vary downward. Where +/- is indicated variation of up to 3% shall be allowable. Alignments of new and existing conditions shall be finished to a smooth and monolithic appearance (gap shall be overlapped to an inside or outside corner where practicable to avoid cracking).
- Do not deviate from the construction documents without the architect's written approval. The contractor agrees to defend indemnify and hold harmless the architect from any claims arising as a result of changes to the work without prior approval from the architect.
- The general contractor shall be responsible for the timely arrival of all specified finish materials, equipment and any other materials to be utilized on the project. The general contractor shall notify the architect in writing within 10 days of date of contract of those specified items that may not be readily available and substitute items of equal quality and description. If notification is not received by the architect, the contractor accepts responsibility for the proper ordering and follow up of specified cost to the owner to insure availability of all specified items so as not to create a hardship on the owner nor delay progress of the work.
- If required construction barriers shall be installed by the general contractor, painted, detailed, and illuminated as per the architect's direction. No signs other than those authorized by the architect or owner will be permitted on this barricade.
- Neither the owner nor the architect will enforce safety measures or regulations. The contractor shall design, install and maintain all safety devices and shall be solely responsible for conforming to all local, state and federal safety and health standards, laws and regulations.
- All existing facilities to be maintained in-place by the contractor unless otherwise shown or directed. Contractor shall take all precautions necessary to support, maintain or otherwise protect existing utilities and other facilities at all times during construction. Contractor shall leave existing facilities in an equal or better-than-original condition and to the satisfaction of the architect/owner.
- The general contractor shall locate all existing utilities whether shown hereon or not and to protect them from damage. The general contractor shall bear all expenses of repair or replacement of utilities or other property damaged by operations in conjunction with the execution of his/her work.
- The general contractor shall secure all permits required by the local jurisdiction, state agency and/or county.
- Mechanical hvac, plumbing, fire suppression, low voltage and electrical work require separate permits. Trade subcontractors shall secure all required permits affecting their scope of work.
- Exit doors shall be operable from the inside without the use of a key or any special knowledge or effort. Exit doors shall swing in the direction of exit travel when serving an occupant load greater than 50.
- Install wall backing for all wall mounted items, including but not limited to the following: door stops, fixtures, wall cabinets, shelving, counters, toilet accessories, security equipment, hand rails, window covering tracks, equipment racks, etc.
- Coordinate location of recessed or semi-recessed items to avoid back to back installation and to reduce noise transfer through partitions.
- Provide water resistant gypsum board at bathtub/shower walls and bathroom ceilings.
- Architect shows fire extinguishers in general logical location: verify requirements and locations with local fire marshal. General contractor to provide fire extinguishers and cabinets (where called out).
- Specifications of material and equipment by the use of name, model number, and/or general coordinate installations with equipment dimensions, including equipment to be installed by the tenant.
- All work shall conform to standards of the industry for first quality workmanship and materials and shall conform to manufacturer's recommendations and specifications.
- Materials are specified by name, model number and description were practicable in order to avoid inaccuracies. The contractor shall review all specifications and notify the architect of any discrepancies in these documents prior to proceeding with the work.
- Floor material changes shall occur at the centerline of doors except where notes. See threshold details for special conditions (if any).
- Blocking and grounds at areas which have millwork, shelving, and tenant furnished furniture wall cabinets indicated on the drawings shall be included with the work.

SUBMITTALS:

- General: the contractor shall submit shop drawings, product data and samples.
- The general contractor shall thoroughly review and check all submittals, coordinating separate trades and verifying conformance with the contract documents. The designer shall not review and will return without review any drawings or submittals not reviewed and noted by the general contractor.
- Submittals shall include shop drawings, schedules and manufacturer's product and equipment cuts for all fixtures, equipment, finishes, special materials, specialties, millwork & casework, doors, frames, and hardware.
- Finish materials: contractor shall submit samples of all finishes and materials, finishes shall be on actual materials.
- Cut sheets: contractor shall submit manufacturer's cuts and spec sheets for all fixtures, including lighting, equipment, special materials, specialties, doors, frames and hardware.
- Minimum sample size:
 - Wood veneered products - 8 ½" x 11" x ¼"
 - Solid lumber - 50 square inches
 - Other finishes and miscellaneous materials - 6" x 6"
- Quantity of submittals:
 - Material samples: 3
 - Shop drawings: 1 pdf
 - Erection drawings: 1 pdf
- Submittal markings: the samples shall bear identification of the project, designer, general contractor, and the manufacturer.
- Quality grade of millwork and casework: AWI quality standards and specifications shall govern according to the following grades:
 - Casework: Premium Grade
 - Natural finish millwork: Premium Grade
 - Running trim: Custom Grade
 - Architectural flush doors (natural finish): Premium Grade

DEFERRED SUBMITTALS:

- Deferred submittal review process: the portions of the project listed below will be constructed using a design/build approach.
- The drawings included in this package are preliminary to provide a basis for bidding and planning.
- Construction drawings for the portions listed are to be provided by the contractor as "deferred submittal" drawings.
- "Deferred submittal" drawings require approval of both architect/engineer and the authority having jurisdiction prior to construction per O.S.S.C. paragraph 107.3.4.2.
- The procedure for deferred submittal is as follows:
 - Contractor to review and provide submittal stamp of approval.
 - Deferred submittal shall be submitted to the architect for review.
 - Following the completion of the architects review the contractor shall submit to the authority having jurisdiction.
 - Work related to deferred submittal items shall not be performed until the deferred submittal documents have been approved by the authority having jurisdiction.
- The contractor is responsible for the following deferred submittals:
 - Electrical service design
 - Mechanical HVAC (Heating Ventilating And Air Conditioning) system design
 - Plumbing service design
 - Fire suppression
 - Fire alarm (where applicable)
- Design-build coordination, design build services shall include but not be limited to the following:
 - Electrical system and service design
 - Mechanical HVAC (Heating Ventilating And Air Conditioning) system design
 - Plumbing system and service design
 - Fire suppression
 - Fire alarm (approved first by general contractor)
- Final design, engineering and shop drawings shall be submitted to architect for review and approval prior to proceeding, shop drawings shall include all materials, configurations, attachments, and finishes.

DESIGN-BUILD NOTES:

- Design/Build - mechanical/electrical/plumbing/sprinkler.
- Design/Build services shall be required of the Contractor for the Mechanical, Electrical, Plumbing, and Sprinkler portions of the work. All systems new and existing shall be designed, modified, provided and/or installed as required by the new layout. Contractor shall submit design drawings and product submittals for all design/build systems to the designer and the building for review and approval.
- Conform to applicable codes, ordinances, specific building standards and industry standards for first class installations of all systems. Comply with building and lease specific requirements for emergency lighting, electrical service and sub-metering (contractor shall be responsible for the verification of adequacy of service and panel space). Contractor shall field verify and confirm with the building prior to submitting their bid for the work.
- Contractors shall be responsible for all design and documentation (including required design documents professionally sealed by an engineer where and as required by the local jurisdiction) as may be required for the full and complete installation of HVAC, power, lighting and sprinkler systems, as well as applying and obtaining all permits, approvals, inspections and certificates required for the completion of the project for occupancy.
- Contractor shall submit HVAC design drawings and product submittals to the designer and the building for review and approval, including clear indications of zones, locations of supply and return diffusers and thermostat locations. Contractor shall provide HVAC balancing report in triplicate to the architect and the building upon completion of the installation and balancing.
- Fire suppression system: contractor shall modify existing fire suppression system consistent with requirements of code, new use, NFPA, and owner's insurance underwriter. Submit shop drawings for approval of building's engineer.
- Sprinkler head types:
 - At gypsum board ceiling: fully recessed flush mounted type with white cover plates.
 - At suspended acoustic tile ceiling: centering not required, maintain min 6" from grid.
- Contractor shall be responsible for complete as-built documents at the completion of the project and shall submit reproducible copies to the landlord for their records.

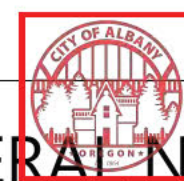

Revised Page

R.C.P. GENERAL NOTES ^{01/30/2026}

- Light fixtures, exit signs and other ceiling elements shall be located in center of individual ceiling plane or tile unless noted otherwise or as directed by architect.
- Provide ceiling access as required for equipment and systems maintenance. Verify manufacturer recommendations.
- Electrical contractor to provide all switches, dimmers and plates as required by design, multiple switches at one location shall be ganged together and furnished with one cover plate.
- The reflected ceiling plan indicates the location of ceiling types, ceiling fixtures light switches and associated items.
- Contractor to notify architect of any conflict of light fixture locations with main runners, ducts, etc. Prior to installation.
- Verify field conditions and locations of all plumbing, mechanical ducts, structural elements and any and all other applicable items. Install new plumbing, mechanical fans, ducts, conduits, and other related items so as to not conflict with lights and any unique field conditions.
- Furnish and install Underwriters Laboratory, Inc. (UL) labeled devices throughout.
- Any lighting control systems which utilize an automatic time switch, occupant-sensing device, automatic daylight control device, lumen maintenance control device or interior photocell sensor, shall be installed in accordance with the manufacturers instruction.
- Automatic daylight control devices and lumen maintenance control devices shall only control luminaries in the day lit area and have photocell sensors that are either ceiling mounted or located so that they are accessible only to authorized personnel.

PLUMBING MECHANICAL GENERAL NOTES:

- Plumbing systems work for this project is shown for design-build guidance.
- All new Plumbing construction shall comply with the current edition of the Oregon Plumbing Specialty Code (OPSC).
- Plumbing fixtures are located on drawings for location only. Confirm fixture selection with owner prior to installation.
- Equipment schedule does not specify any plumbing fixtures such as grease traps, faucets, pressure reducing valves, etc. Nor does it include final connection to service. Plumbing contractor to provide if necessary.
- Contractor or its subcontractors shall be responsible for obtaining and paying for all inspections and tests required by any governmental agency to implement the plans and accept any required special inspections or reports, which shall be paid for by the owner.
- Plumbing requirements shown only for items listed on equipment schedule.
- Plumbing contractor to provide rough-in and final connect.
- Although some floor drains may be shown on plans, provide all required floor drains per the plumbing code.

HVAC MECHANICAL GENERAL NOTES:

- Mechanical HVAC work for this project is shown for design-build guidance.
- All new HVAC construction shall comply with the current edition of the Oregon Mechanical Specialty Code (OMSC).
- Mechanical HVAC work for this project consists in air handlers, exhaust fans and duct work as well as any code mandated ventilation.
- Exhaust fans and circulation fans are located on drawings for general location only. Sizing is the responsibility of the design build contractor. Confirm equipment selection with owner prior to installation.
- HVAC subcontractor to provide submittal information, including Mechanical COMcheck forms, and receive owner approval prior to ordering equipment.
- Contractor is required to review the drawings of all divisions of work contractor is responsible for coordination of this work and the work of all subcontractors with all divisions of work. It is this contractor's responsibility to provide all the subcontractors with a complete set of bid documents.
- Contractor or its subcontractors shall be responsible for obtaining and paying for all inspections and tests required by any governmental agency to implement the plans and accept any required special inspections or reports, which shall be paid for by the owner.
- The contractor shall furnish and install any additional structural steel required to support any mechanical equipment. This contractor shall coordinate locations and requirements with the general contractor and landlord prior to bid.

ELECTRICAL GENERAL NOTES:



Permit Number:

BLD-0058-25

- Electrical work for this project is shown for design-build guidance.
- All new Electrical construction shall comply with the current edition of the Oregon Electrical Specialty Code (OESC).
- Electrical subcontractor to provide submittal information, including Lighting COMcheck forms, and receive owner approval prior to ordering equipment.
- Contractor and subcontractors are required to review the drawings for all divisions of work. Contractor is responsible for coordination of this work and the work of all subcontractors with all divisions of work including electrical demolition. It is this contractor's responsibility to provide all the subcontractors with a complete set of bid documents.
- Contractor or its subcontractors shall be responsible for obtaining and paying for all inspections and tests required by any governmental agency to implement the plans and accept any required special inspections or reports, which shall be paid for by the owner.
- Electrical information provided on architectural floor plans is for reference only, electrical design build subcontractor to confirm and coordinate all work.
- Placement of light fixtures in ceiling planes takes precedence over all other services including fire protection or suppression devices.
- Placement of receptacles, convenience outlets, switches, smoke detectors, etc must meet electrical code requirements, accessibility requirements and must be rationally laid out in the space available.
- Circuiting indicated on plan is partially diagrammatic for clarity. Circuiting shall be "thru-wiring" where and whenever possible.
- Field verify exact location and electrical requirements of all HVAC equipment with mechanical contractor prior to ordering related electrical equipment.
- Coordinate with tenant's equipment power requirements.
- Electrical contractor shall make all final connections as required for a fully complete and operable system.
- All stub-up dimensions from finished floor to center of box.
- Equipment listed on equipment schedule will be uncrated and set in place only. Rough in and final hookup will be performed by the electrical contractor.
- All electrical outlets and connections to be grounded type.
- Electrical contractor to furnish disconnects where code requires.
- Equipment listed on the equipment schedule does not include electrical fittings such as relays or disconnects to the electrical service.
- Plugs should enter receptacle from the dimension side of symbols unless noted otherwise.

FIRE SUPPRESSION SYSTEM GENERAL NOTES:

Contractor qualifications:

- Established fire protection contractor regularly engaged in the design and installation of automatic fire sprinkler systems.
- Employ workers experienced and skilled in this trade.
- System designer: qualified and certified for the design of fire protection sprinkler systems. NICET level III or IV technician or professional engineer experienced in the design of sprinkler systems.

Governing agency: all work in accordance with and accepted by the following hereafter referred to governing agencies:

- State of Oregon Fire Marshal.
- City of Albany, Fire Marshal.

Design requirements:

- Comply with the latest issue of NFPA Standard 13.
- Design, lay out and install hydraulically calculated wet and dry pipe systems, including standpipes, utilizing code approved automatic devices designed particularly for use in this type of system.
- Provide hydraulic calculation methods design data information in accordance with NFPA 13. Include all friction losses from point of flow test to remote sprinkler area.
- Fire sprinkler coverage: as required by the governing agency and including fire protection of all areas including the following:
 - Exterior canopies of combustible construction.
 - Covered decks and patios.
 - Covered parking areas.
 - Attic spaces of combustible construction.
 - Window wash sprinklers at exposures.
- Occupancy hazard: occupancy hazard designation in accordance with the governing agency requirements.
- Seismic restraint: include load calculations for seismic restraints.
- Contractor shall review all drawings and determine where unheated spaces, concealed combustible spaces, overhead doors, or similar special conditions exist and provide sprinkler protection as required.
- Revisions to the contractor's design required by the governing agency shall be at the contractor's expense.

LIFT

ARCHITECTURE

1130 Liberty St SE Suite 230 | Salem, OR 97302



ADDITION & REMODEL

BRIGGS BUILDING

333 W 1ST AVE ALBANY OR. 97321

REVISIONS:

SHEET:

G0.02

GENERAL NOTES

PROJECT # 2024-014

DATE: 3/4/2025

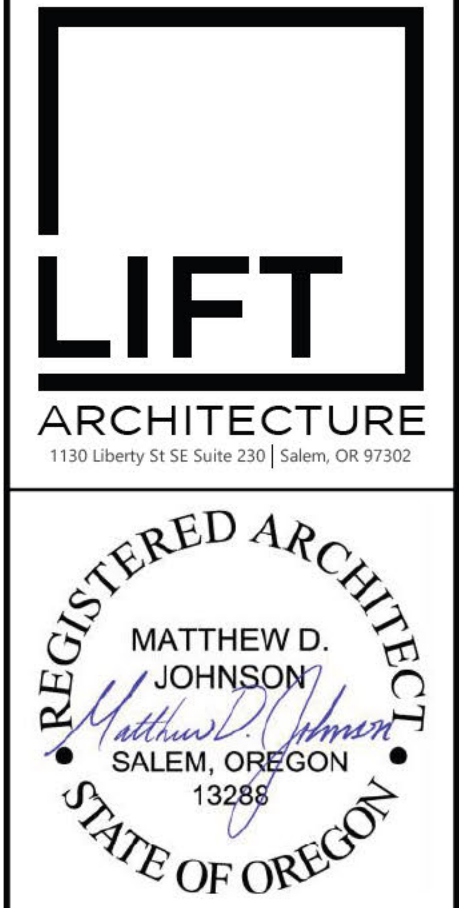

ADDITION & REMODEL
BRIGGS BUILDING
333 W 1ST AVE ALBANY OR. 97321

REVISIONS:

2	5/2/2025	Plan Review
4	1/28/2026	Sprinklers/Elevations

SHEET:
G1.01
CODE REVIEW PLANS

PROJECT # 2024-014
DATE: 3/4/2025

PROJECT NAME: BRIGGS BUILDING
ADDRESS: 333 W 1ST AVE, ALBANY OR. 97321
PROJECT No: 2024-014

SEPARATE PERMITS:
• FIRE SPRINKLERS
• MECHANICAL
• ELECTRICAL
• PLUMBING

GOVERNING CODES:
• Structural - Life Safety: 2022 Oregon Structural Specialty Code (OSSC)
• Mechanical: 2022 Oregon Mechanical Specialty Code (OMSC)
• Plumbing: 2021 Oregon Plumbing Specialty Code (OPSC)
• Electrical: 2021 Oregon Electrical Specialty Code (OESC)
• Energy: 2021 Oregon Energy Efficiency Specialty Code (OEESC)
• 2019 Oregon Zero Energy Ready Specialty Code (OZERCC)
• Fire Sprinklers: NFPA 13 (or 13R) - Standard for the Installation of Sprinkler Systems
• Fire Alarm: NFPA 72 - National Fire Alarm Code
• Gas Code: 2022 Oregon Mechanical Specialty Code
• Accessibility: ICC/ANSI A117.1-2017 Standard for Accessible and Usable Buildings and Facilities

USE AND OCCUPANCY CLASSIFICATION:
• "A-2" "Restaurant" Section 303.3
• "R-2" "Apartments" Section 310.3

CONSTRUCTION TYPE:
• Type V-B, Fully-sprinklered with NFPA 13R system.
• Ground floor sprinkler head installation/coverage to comply with NFPA 13 requirements for A-2 occupancy.
• Floors 2-3 head installation/coverage to comply with NFPA 13R standards for R-2 occupancy.

OCCUPANCY SEPARATIONS: per Section 508.4:
• Project requires 1 hr fire separation between A-2 and R-2 occupancy classifications with automatic sprinkler system installed in accordance with Section 903.3.1.1.

ALLOWABLE HEIGHT CALCULATIONS:
For "A-2" in Type V-B Construction:
• Allowable Height per Table 504.3: = 60 ft.
• Actual Building Height to top of parapet: = 41 ft.

For "R-2" in Type V-B Construction:
• Allowable Height per Table 504.3: = 60 ft.
• Actual Building Height to top of parapet: = 41 ft.

ALLOWABLE NUMBER OF STORIES ABOVE GRADE PLANE:
For "A-2" in Type V-B Construction:
• Allowable Number of Stories per Table 504.4: = 2 story.
• Actual Number of Stories: = 1 story.

For "R-2" in Type V-B Construction:
• Allowable Number of Stories per Table 504.4: = 3 stories.
• Actual Number of Stories: = 2 stories.

ALLOWABLE AREA CALCULATIONS:
 $A_a = A_t + [NS \times If] \times S_a$ = Allowable area per story in square feet.
 A_t = NS Tabular Area per story in accordance with Table 506.2
 NS = Tabular Area for Non Sprinklered Buildings in accordance with Table 506.2
 If = $[F/P - 0.25] \times W/30$ = Area increase due to frontage per Section 506.2.
 S_a = Actual number of stories above Grade Plane, not to exceed 3 for Non-Sprinklered Buildings, and not to exceed 4 for NFPA 13 Sprinklered Buildings.
 F = Building Perimeter which fronts on a public way or open space having 20ft min. open width.
 P = Perimeter of entire building.
 W = Width of public way or open space per 506.3, (Minimum 20ft and Maximum 30ft)

Construction Type: V-B "A-2" Occupancy
 A_t = 18,000
 If = 0.750
 S_a = 1
 F = 49 ft
 P = 248 ft
Therefore: Allowable Area per Floor = 53,065 s.f.
Allowable Area per Building = 53,065 s.f.

Construction Type: V-B "R-2" Occupancy
 A_t = 21,000
Therefore: Allowable Area per Floor = 61,899 s.f.
Allowable Area per Building = 123,798 s.f.

ACTUAL AREA PER FLOOR:
• LEVEL 01: (Ground Floor) = 2,384 s.f. < 35,625 s.f. PERMITTED
• LEVEL 02: (Second Floor) = 2,401 s.f. < 35,625 s.f. PERMITTED
• LEVEL 03: (Third Floor) = 971 s.f. < 35,625 s.f. PERMITTED

ACTUAL AREA PER BUILDING:
• LEVEL 01: (Ground Floor) = 2,384 s.f.
• LEVEL 02: (Second Floor) = 2,401 s.f.
• LEVEL 03: (Third Floor) = 971 s.f.
• TOTAL: = 5,756 s.f. < 123,798 s.f. PERMITTED

FIRE RESISTANCE RATING REQUIREMENTS FOR BUILDING ELEMENTS IN HOURS per Table 601 and 602

• Primary Structural Frame Including Columns, and Girders:	0 hrs
• Bearing Walls, Exterior:	0 hrs
• Bearing Walls, Interior:	0 hrs
• Non-bearing Walls, Exterior:	< 5' to property line 1 hrs
• Non-bearing Walls, Exterior:	> 5' but < 10' to property line 1 hrs
• Non-bearing Walls, Exterior:	> 10' but < 30' to property line 1 hrs
• Non-bearing Walls, Exterior:	≥ 30' to property line 0 hrs
• Non-bearing Walls and Partitions, Interior:	0 hrs
• Floor Construction Including supporting beams and joists:	0 hrs
• Roof Construction:	0 hrs

INTERIOR FINISHES: Table 803.13 for "A-2" Occ
• Exit Enclosures and Exit Passages: Class B: Flame Spread 26-75; Smoke -developed 0-450 N/A
• Corridors: Class B: Flame Spread 26-75; Smoke -developed 0-450 N/A
• All other spaces: Class C: Flame Spread 76-200; Smoke -developed 0-450

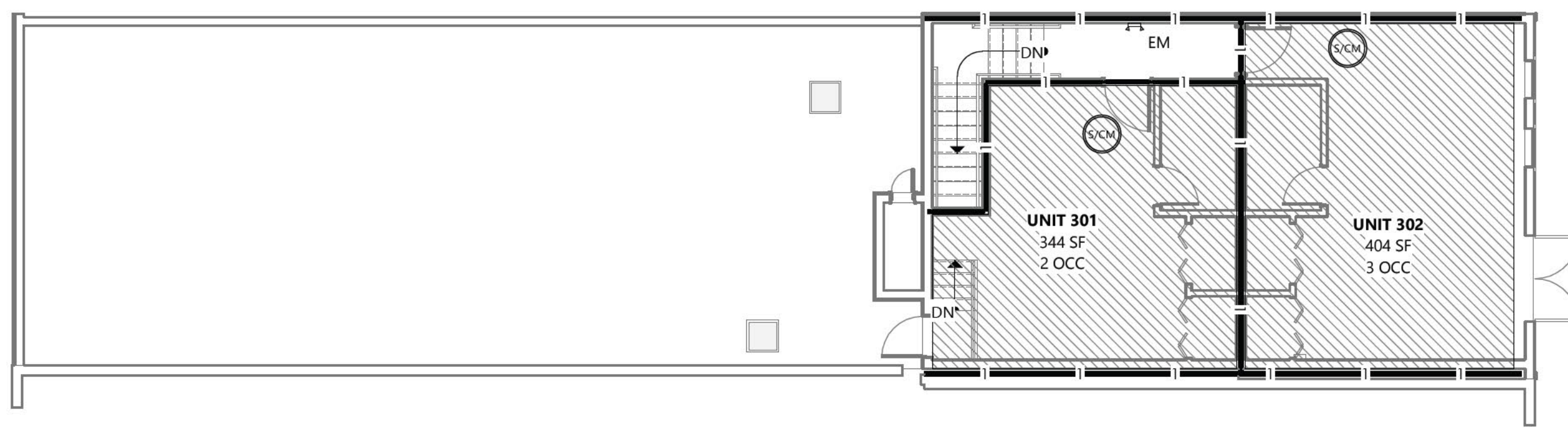

1 LEVEL 03 - CODE REVIEW
SCALE: 1/8" = 1'-0"

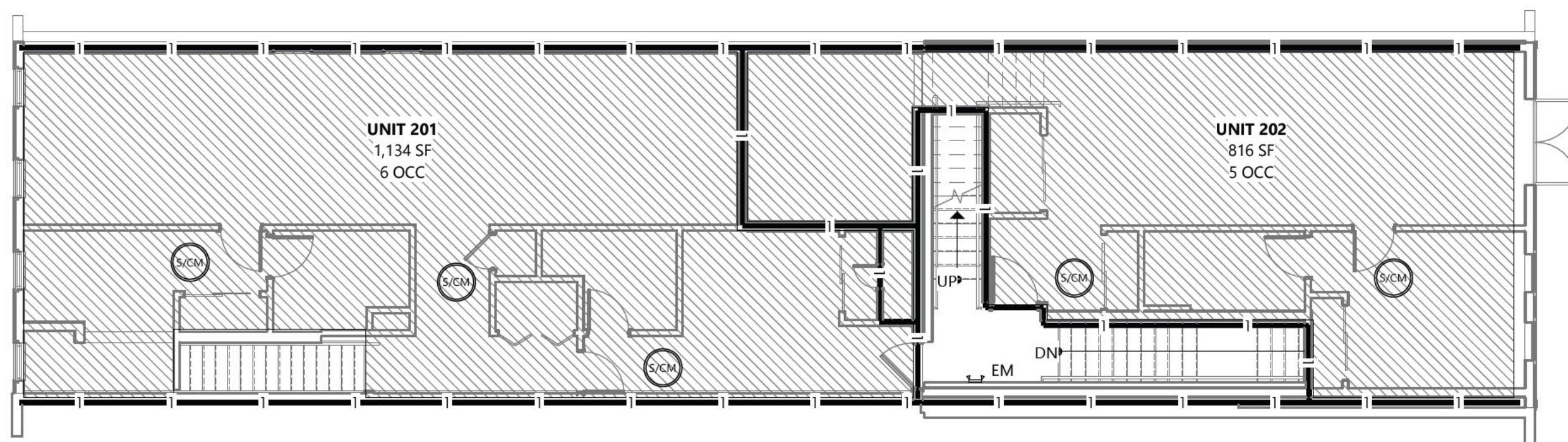

2 LEVEL 02 - CODE REVIEW
SCALE: 1/8" = 1'-0"

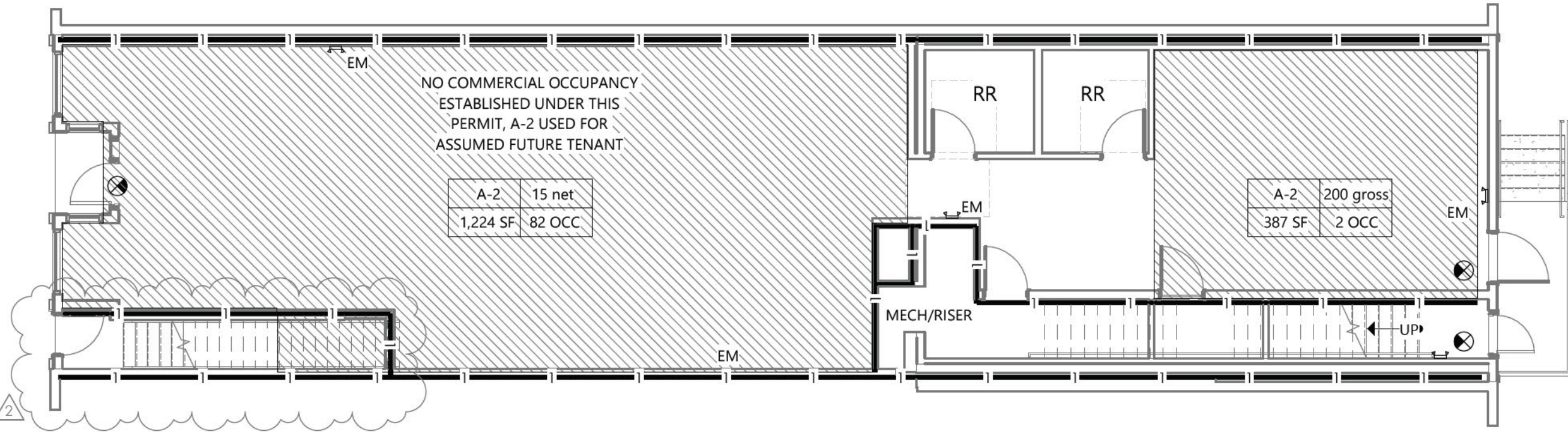

3 LEVEL 01 - CODE REVIEW
SCALE: 1/8" = 1'-0"

Revised Page
01/30/2026

Permit Number:
BLD-0058-25

EXTERIOR WALL ASSEMBLY: NOT RATED

VERTICAL 3/8" P.T. STRIPS ALIGNED WITH STUDS.
SIDING PER ELEVATIONS.
VAPOR PERMEABLE WEATHER RESISTIVE BARRIER, TYP.
EXTERIOR WALL SHEATHING PER STRUCTURAL.
2X6 WOOD STUDS 16" O.C. (U.N.O. PER STRUCTURAL).
FILL STUD CAVITY WITH MINERAL FIBER, GLASS FIBER, OR CELLULOSE FIBER INSULATION, R-21 MINIMUM WITH INTEGRAL KRAFT PAPER BARRIER TO INTERIOR SIDE.
INTERIOR SIDE: ONE LAYER 5/8" GYPSUM WALLBOARD.

EXTERIOR SIDE INTERIOR SIDE

F.R. | N/A
STC | N/A

EXTERIOR WALL TYPE: **AA**

EXTERIOR WALL ASSEMBLY: 2-HOUR PROVIDED BY CMU

2"x4" WOOD STUDS @ 16" O.C.
5/8" GYPSUM WALLBOARD, TEXTURE, PRIME, AND PAINT.
R-21 MINERAL WOOL INSULATION BATTS EACH BAY.
NEW 8" CMU WALL.
SELF-ADHERED WEATHER RESISTIVE BARRIER.
EXISTING EXTERIOR WALL OF ABUTTING BUILDING.

F.R. | 2-HR
STC | N/A

EXTERIOR WALL TYPE: **AB**

EXTERIOR WALL ASSEMBLY: GA FILE WP 8105 1-HOUR RATING

SIDING PER ELEVATIONS.
VAPOR PERMEABLE WEATHER RESISTIVE BARRIER W/ INTEGRAL RAINSCREEN, TYP.
EXTERIOR SIDE: ONE LAYER 48" WIDE 5/8" TYPE X GYPSUM SHEATHING APPLIED PARALLEL TO 2 X 6 WOOD STUDS 24" O.C. WITH 1 3/4" GALVANIZED ROOFING NAILS 4" O.C. AT VERTICAL JOINTS AND 7" O.C. AT INTERMEDIATE STUDS AND TOP AND BOTTOM PLATES. JOINTS OF GYPSUM SHEATHING MAY BE LEFT UNTREATED. EXTERIOR CLADDING TO BE ATTACHED THROUGH SHEATHING TO STUDS.
EXTERIOR WALL SHEATHING PER STRUCTURAL.
FILL STUD CAVITY WITH MINERAL FIBER, GLASS FIBER, OR CELLULOSE FIBER INSULATION, R-21 MINIMUM WITH INTEGRAL KRAFT PAPER BARRIER TO INTERIOR SIDE.
2X6 WOOD STUDS 16" O.C. (U.N.O. PER STRUCTURAL).
INTERIOR SIDE: ONE LAYER 5/8" TYPE X GYPSUM WALLBOARD, WATER-RESISTANT GYPSUM BACKING BOARD, OR GYPSUM VENEER BASE APPLIED PARALLEL OR AT RIGHT ANGLES TO STUDS WITH 6D COATED NAILS, 17/8" LONG, 0.0915" SHANK, 1/4" HEADS, 7" O.C. (LOAD-BEARING)

EXTERIOR SIDE INTERIOR SIDE

F.R. | 1-HR
STC | N/A

EXTERIOR WALL TYPE: **AC**

EXTERIOR WALL ASSEMBLY: GA FILE WP 8105 1-HOUR RATING

EXTERIOR SIDE: ONE LAYER 48" WIDE 5/8" TYPE X GYPSUM SHEATHING APPLIED PARALLEL TO 2 X 6 WOOD STUDS 24" O.C. WITH 1 3/4" GALVANIZED ROOFING NAILS 4" O.C. AT VERTICAL JOINTS AND 7" O.C. AT INTERMEDIATE STUDS AND TOP AND BOTTOM PLATES. JOINTS OF GYPSUM SHEATHING MAY BE LEFT UNTREATED. EXTERIOR CLADDING TO BE ATTACHED THROUGH SHEATHING TO STUDS.
FILL STUD CAVITY WITH MINERAL FIBER, GLASS FIBER, OR CELLULOSE FIBER INSULATION, R-21 MINIMUM WITH INTEGRAL KRAFT PAPER BARRIER TO INTERIOR SIDE.
2X6 WOOD STUDS 16" O.C. (U.N.O. PER STRUCTURAL).
INTERIOR SIDE: ONE LAYER 5/8" TYPE X GYPSUM WALLBOARD, WATER-RESISTANT GYPSUM BACKING BOARD, OR GYPSUM VENEER BASE APPLIED PARALLEL OR AT RIGHT ANGLES TO STUDS WITH 6D COATED NAILS, 17/8" LONG, 0.0915" SHANK, 1/4" HEADS, 7" O.C. (LOAD-BEARING)

EXTERIOR SIDE INTERIOR SIDE

F.R. | 1-HR
STC | N/A

EXTERIOR WALL TYPE: **AD**

INTERIOR WALL ASSEMBLY: NOT RATED

ONE LAYER 5/8" GYPSUM WALLBOARD BOTH SIDES OF 2X4 OR 2X6 WOOD FRAMING AT 16" O.C. (U.O.N. PER STRUCTURAL).
PRIME AND PAINT EACH SIDE OF WALL. SEE SECTIONS FOR TOP/BOTTOM PLATE CONDITIONS.

F.R. | N/A
STC | N/A

INTERIOR PARTITION TYPE: **BA**

GA FILE NO. WP 3243 1-HOUR RATING

RESILIENT CHANNELS 24" O.C. ATTACHED AT RIGHT ANGLES TO ONE SIDE OF 2x6 WOOD STUDS 16" O.C. WITH 1 1/4" TYPE S DRYWALL SCREWS. ONE LAYER 5/8" TYPE "X" GYPSUM WALLBOARD APPLIED AT RIGHT ANGLES TO CHANNELS WITH 1" TYPE "S" DRYWALL SCREWS 8" O.C. WITH VERTICAL JOINTS LOCATED MIDWAY BETWEEN STUDS. 3 1/2" MINERAL OR GLASS FIBER INSULATION IN STUD SPACE.
OPPOSITE SIDE: BASE LAYER 5/8" TYPE "X" GYPSUM WALLBOARD OR GYPSUM VENEER BASE APPLIED PARALLEL OR AT RIGHT ANGLES TO STUDS WITH 6D CEMENT COATED NAILS, 1 7/8" LONG, 0.0915" SHANK, 15/64" HEADS, 7" O.C.
VERTICAL JOINTS STAGGERED 16" ON OPPOSITE SIDES. (LOAD-BEARING)
NOTE: WATER RESISTANT GYPSUM WALLBOARD USED AS FACE LAYER IN ALL BATH AND TOILET ROOMS.
1/2" PLYWOOD SHEATHING FOR SHEAR, AS OCCURS PER STRUCTURAL DRAWINGS.
PRIME AND PAINT EACH SIDE OF WALL. SEE SECTIONS FOR TOP/BOTTOM PLATE CONDITIONS.

F.R. | 1-HR
STC | 55-59

DEMISING WALL: **BB**

INTERIOR WALL ASSEMBLY: GA FILE NO. WP 3614 1-HOUR RATING

ONE LAYER 5/8" TYPE "X" GYPSUM WALLBOARD APPLIED PARALLEL OR AT RIGHT ANGLES TO EACH SIDE OF 2x STUDS PER DIMENSION PLAN @ 16" O.C. WITH 1-1/4" TYPE "W" DRYWALL SCREWS 12" O.C.
PRIME AND PAINT EACH SIDE OF WALL. SEE SECTIONS FOR TOP/BOTTOM PLATE CONDITIONS.

F.R. | 1-HR
STC | N/A

INTERIOR PARTITION TYPE: **BC**

GA FILE NO. WP 3243 1-HOUR RATING

RESILIENT CHANNELS 24" O.C. ATTACHED AT RIGHT ANGLES TO ONE SIDE OF 2x4 WOOD STUDS 16" O.C. WITH 1 1/4" TYPE S DRYWALL SCREWS. ONE LAYER 5/8" TYPE "X" GYPSUM WALLBOARD APPLIED AT RIGHT ANGLES TO CHANNELS WITH 1" TYPE "S" DRYWALL SCREWS 8" O.C. WITH VERTICAL JOINTS LOCATED MIDWAY BETWEEN STUDS. 3 1/2" MINERAL OR GLASS FIBER INSULATION IN STUD SPACE.
OPPOSITE SIDE: BASE LAYER 5/8" TYPE "X" GYPSUM WALLBOARD OR GYPSUM VENEER BASE APPLIED PARALLEL OR AT RIGHT ANGLES TO STUDS WITH 6D CEMENT COATED NAILS, 1 7/8" LONG, 0.0915" SHANK, 15/64" HEADS, 7" O.C.
VERTICAL JOINTS STAGGERED 16" ON OPPOSITE SIDES. (LOAD-BEARING)
NOTE: WATER RESISTANT GYPSUM WALLBOARD USED AS FACE LAYER IN ALL BATH AND TOILET ROOMS.
1/2" PLYWOOD SHEATHING FOR SHEAR, AS OCCURS PER STRUCTURAL DRAWINGS.
PRIME AND PAINT EACH SIDE OF WALL. SEE SECTIONS FOR TOP/BOTTOM PLATE CONDITIONS.

F.R. | 1-HR
STC | 50-54

DEMISING WALL: **BD**



REGISTERED ARCHITECT
MATTHEW D. JOHNSON
SALEM, OREGON 97302

ADDITION & REMODEL
BRIGGS BUILDING
333 W 1ST AVE ALBANY OR. 97321

REVISIONS:

SHEET:
A0.21

VERTICAL ASSEMBLIES

PROJECT # 2024-014
DATE: 3/4/2025

INTERIOR FLOOR ASSEMBLY, 1-HOUR RATED: UL 263/BXUV M532
STC 57 AND IIC 54 PROVIDED BY PROPRIETARY FLOORING W/
INTEGRAL SOUND MAT

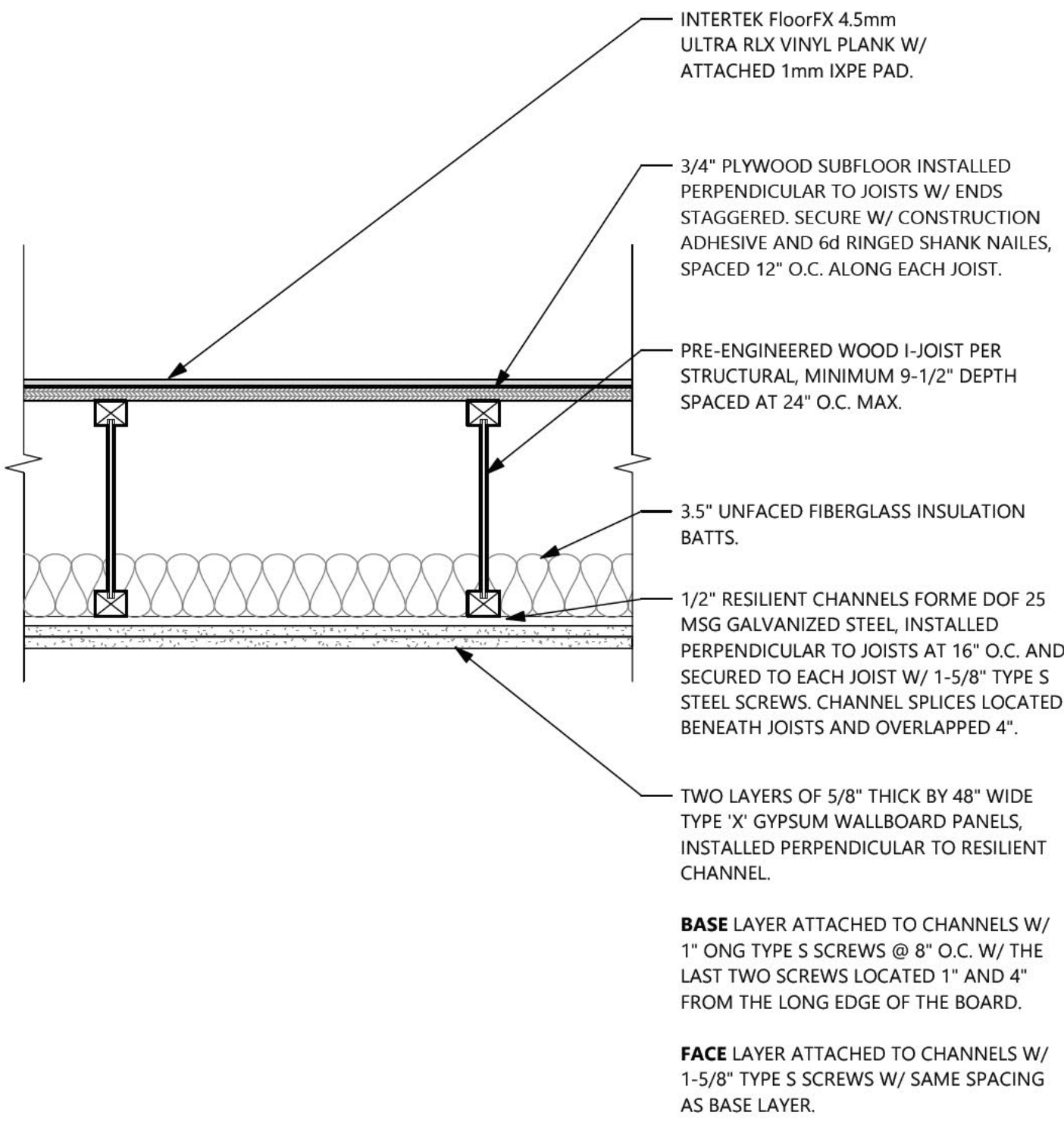

F.R. | 1 HR
STC | 57
TYPICAL FLOOR ASSEMBLY: F-1

INTERIOR FLOOR ASSEMBLY, NON-RATED

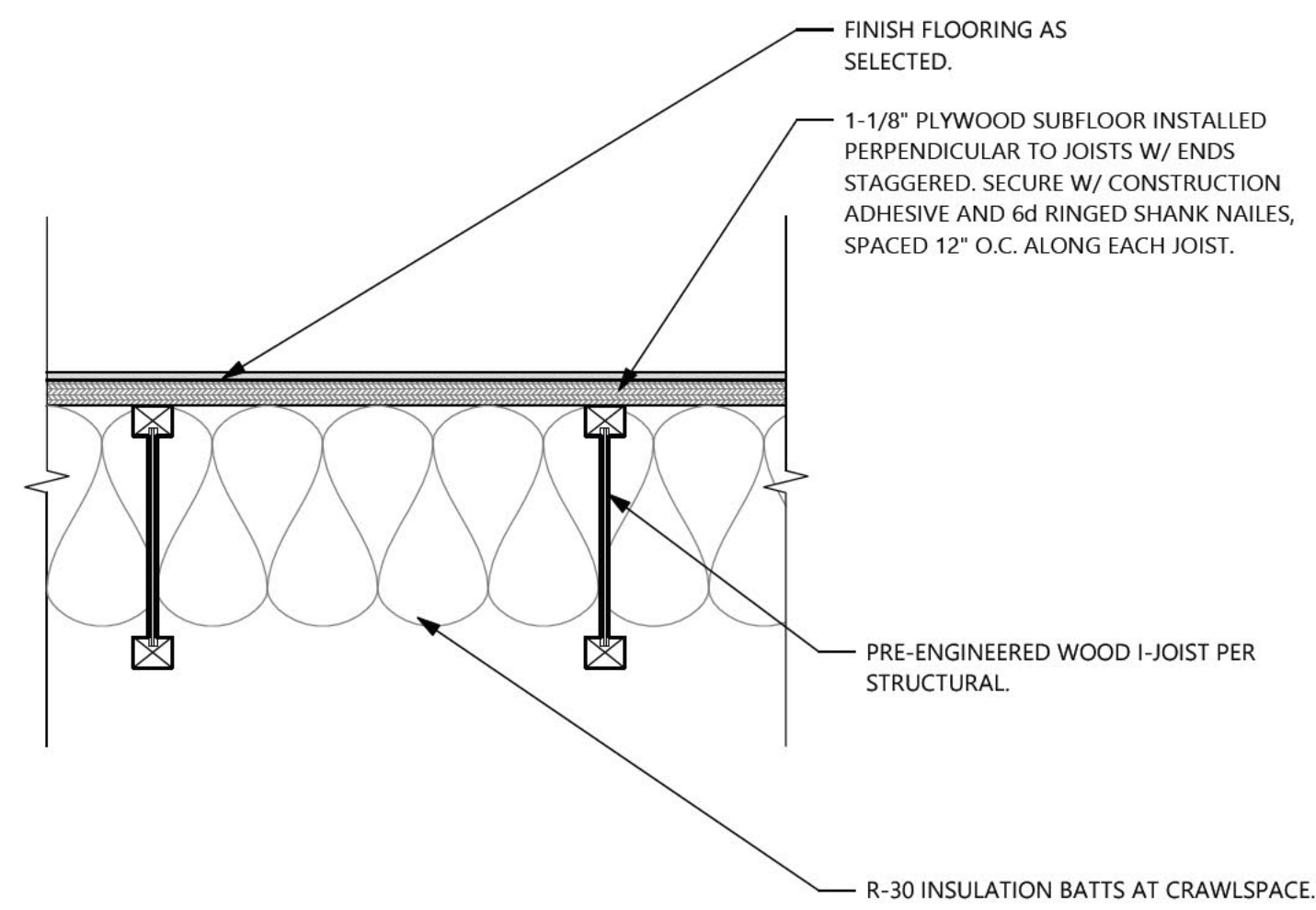

F.R. | N/A
STC | N/A
TYPICAL FLOOR ASSEMBLY: F-2

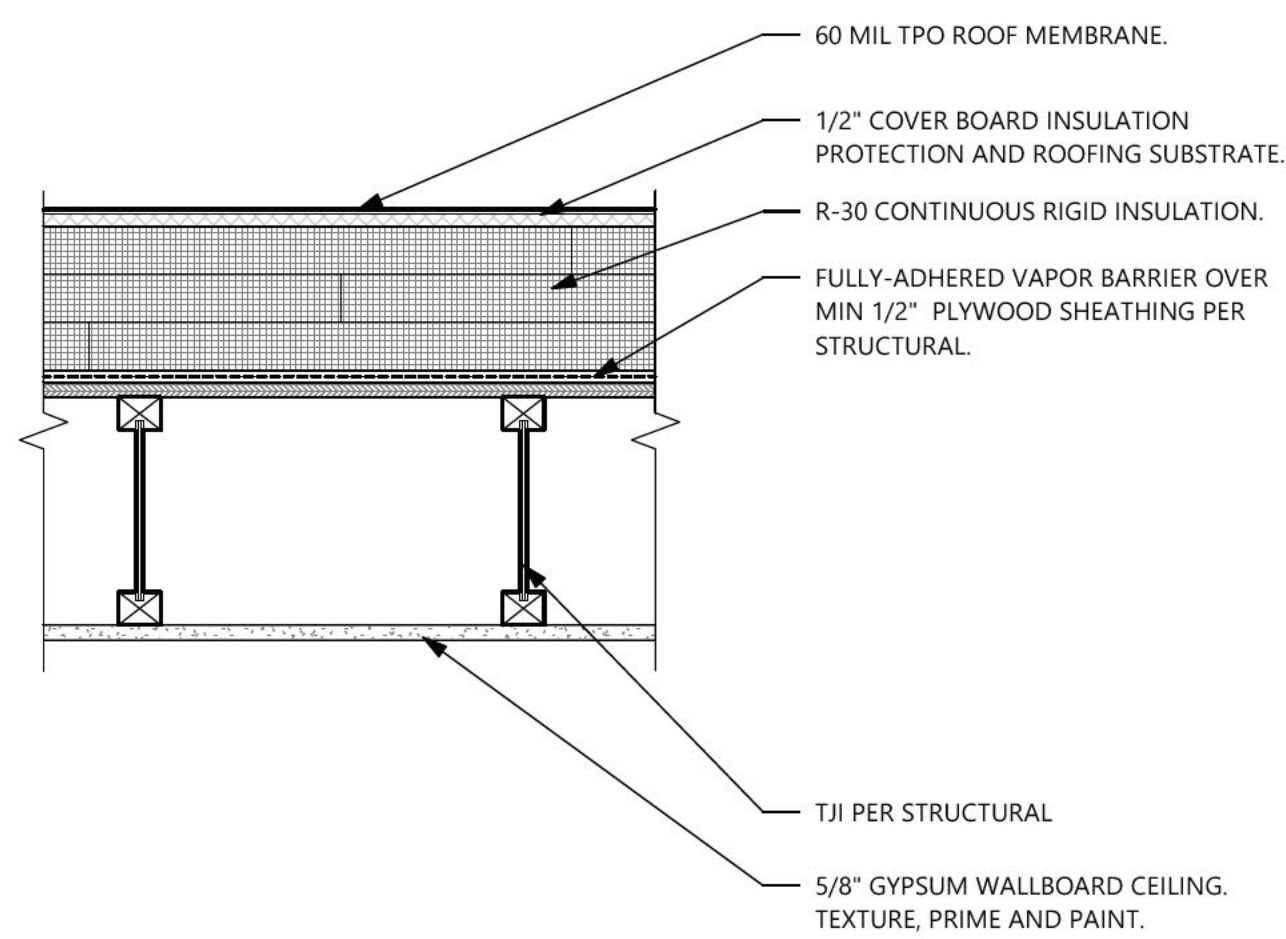

F.R. |
STC |
ROOF/CEILING ASSEMBLY: R-1



ADDITION & REMODEL
BRIGGS BUILDING
333 W 1ST AVE ALBANY OR. 97321

REVISIONS:

SHEET:

A0.22

HORIZONTAL ASSEMBLIES

PROJECT # 2024-014

DATE: 3/4/2025

Permit Number: **BLD-0058-25**

NO.	DESCRIPTION
1	NOT USED.
2	NEW SKYLIGHT OVERHEAD.
3	EXISTING ELECTRICAL METER LOCATION.
4	EXISTING GAS METER LOCATION.
5	ELECTRIC IN-LINE WATER HEATER.
6	NOT USED.
7	NOT USED.
8	NEW STACKED WASHER/DRYER. CONFIRM MAKE AND MODEL WITH OWNER.
9	PLUMBING STUBS FOR FUTURE RESTROOM FIXTURES.
10	FIRE RISER TO SERVE UPPER FLOORS W/ NFPA 13R SYSTEM
11	MINI SPLIT, PER OWNER.
12	WALL-MOUNTED CONDENSER UNITS FOR DUCTLESS MINI-SPLITS, TO BE DESIGN-BUILD BY MECHANICAL CONTRACTOR.
13	1-HOUR FIRE-RESISTANCE RATED WALL ASSEMBLY SEPARATING STAIR FROM COMMERCIAL SPACE. MATCH WALL ASSEMBLY 'BB' AT EXISTING FRAMING, PROVIDE NEW FRAMING TO MATCH EXISTING STAIR/OPENING.

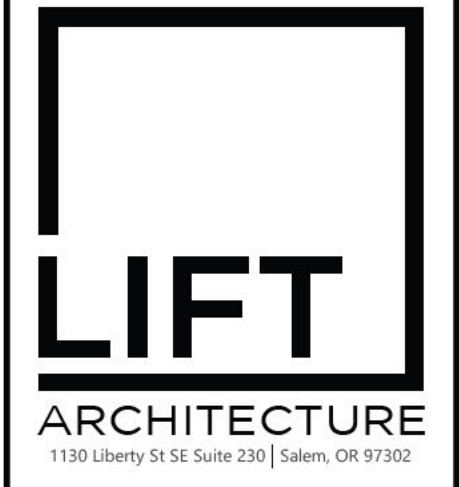

ADDITION & REMODEL
BRIGGS BUILDING
333 W 1ST AVE ALBANY OR. 97321

REVISIONS:

1	4/10/2025	Rear Elevation
2	5/2/2025	Plan Review
3	9/2/2025	Match Ex. Cond.

SHEET:
A1.21

LEVEL 01 - FLOOR PLAN

PROJECT # 2024-014
DATE: 3/4/2025

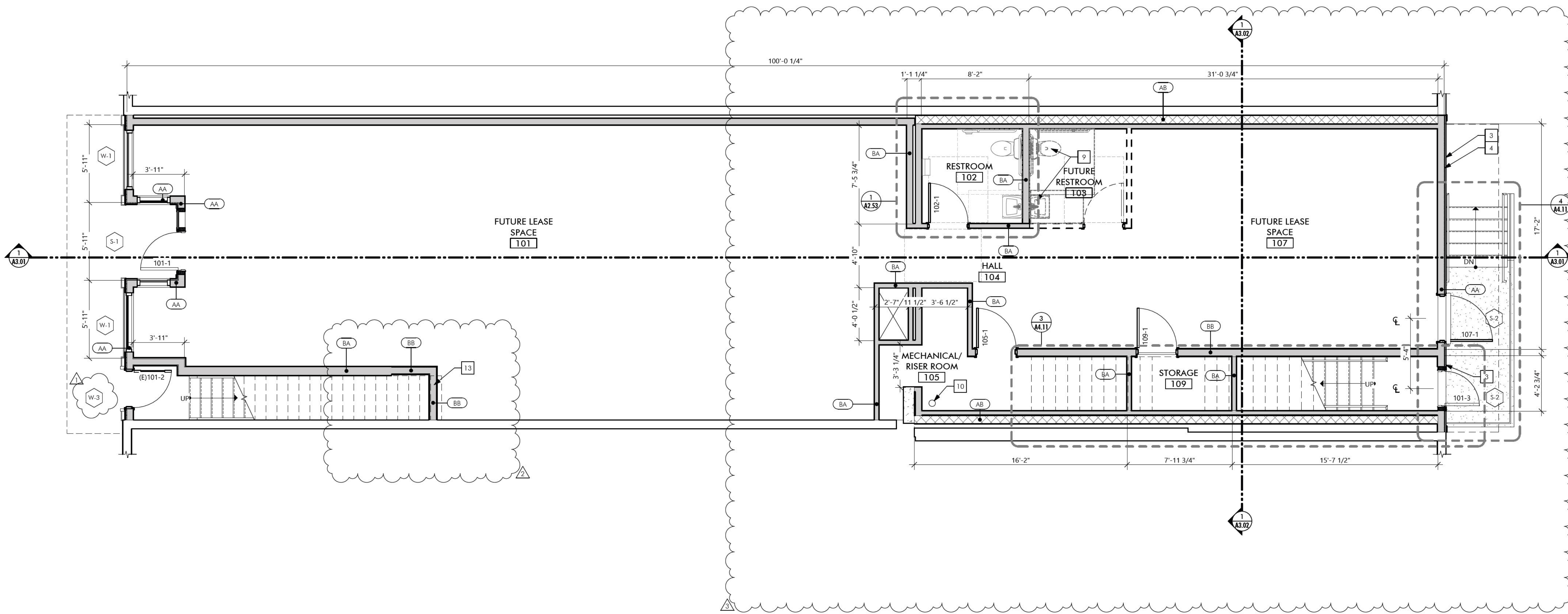

1 LEVEL 01
SCALE: 1/4" = 1'-0"

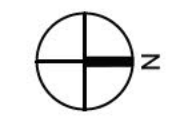

Permit Number: BLD-0058-25	
NO.	DESCRIPTION
1	NOT USED.
2	NEW SKYLIGHT OVERHEAD.
3	EXISTING ELECTRICAL METER LOCATION.
4	EXISTING GAS METER LOCATION.
5	ELECTRIC IN-LIME WATER HEATER.
6	NOT USED.
7	NOT USED.
8	NEW STACKED WASHER/DRYER. CONFIRM MAKE AND MODEL WITH OWNER.
9	PLUMBING STUBS FOR FUTURE RESTROOM FIXTURES.
10	FIRE RISER TO SERVE UPPER FLOORS W/ NFPA 13R SYSTEM
11	MINI SPLIT, PER OWNER.
12	WALL-MOUNTED CONDENSER UNITS FOR DUCTLESS MINI-SPLITS, TO BE DESIGN-BUILD BY MECHANICAL CONTRACTOR.
13	1-HOUR FIRE-RESISTANCE RATED WALL ASSEMBLY SEPARATING STAIR FROM COMMERCIAL SPACE. MATCH WALL ASSEMBLY 'BB' AT EXISTING FRAMING, PROVIDE NEW FRAMING TO MATCH EXISTING STAIR/OPENING.



ADDITION & REMODEL BRIGGS BUILDING

333 W 1ST AVE ALBANY OR. 97321

REVISIONS:

1	4/10/2025	Rear Elevation
3	9/2/2025	Match Ex. Cond.

SHEET:
A1.22
LEVEL 02 - FLOOR PLAN

PROJECT # 2024-014
DATE: 3/4/2025

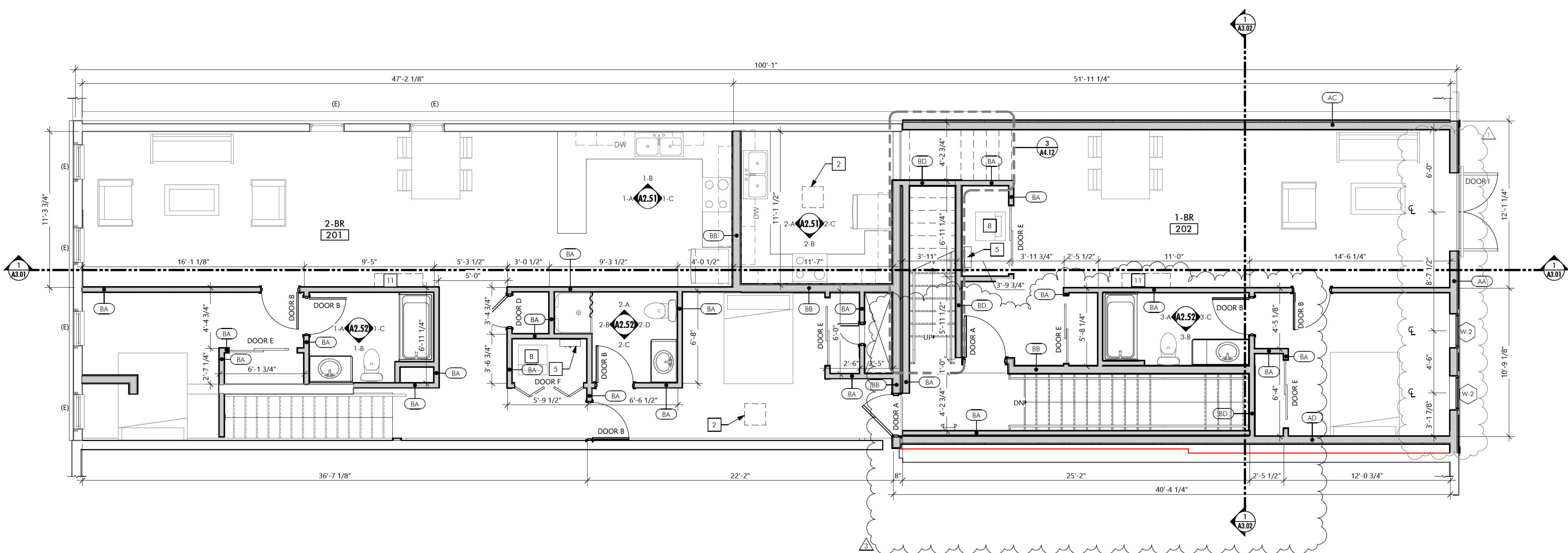

1 LEVEL 02
SCALE: 1/4" = 1'-0"



Permit Number: **BLD-0058-25**

NO.	DESCRIPTION
1	NOT USED.
2	NEW SKYLIGHT OVERHEAD.
3	EXISTING ELECTRICAL METER LOCATION.
4	EXISTING GAS METER LOCATION.
5	ELECTRIC IN-LINE WATER HEATER.
6	NOT USED.
7	NOT USED.
8	NEW STACKED WASHER/DRYER. CONFIRM MAKE AND MODEL WITH OWNER.
9	PLUMBING STUBS FOR FUTURE RESTROOM FIXTURES.
10	FIRE RISER TO SERVE UPPER FLOORS W/ NFPA 13R SYSTEM
11	MINI SPLIT, PER OWNER.
12	WALL-MOUNTED CONDENSER UNITS FOR DUCTLESS MINI-SPLITS, TO BE DESIGN-BUILD BY MECHANICAL CONTRACTOR.
13	1-HOUR FIRE-RESISTANCE RATED WALL ASSEMBLY SEPARATING STAIR FROM COMMERCIAL SPACE. MATCH WALL ASSEMBLY 'BB' AT EXISTING FRAMING, PROVIDE NEW FRAMING TO MATCH EXISTING STAIR/OPENING.



ADDITION & REMODEL
BRIGGS BUILDING
333 W 1ST AVE ALBANY OR. 97321

REVISIONS:

1	4/10/2025	Rear Elevation
---	-----------	----------------

SHEET:
A1.23
LEVEL 03 - FLOOR PLAN

PROJECT # 2024-014
DATE: 3/4/2025

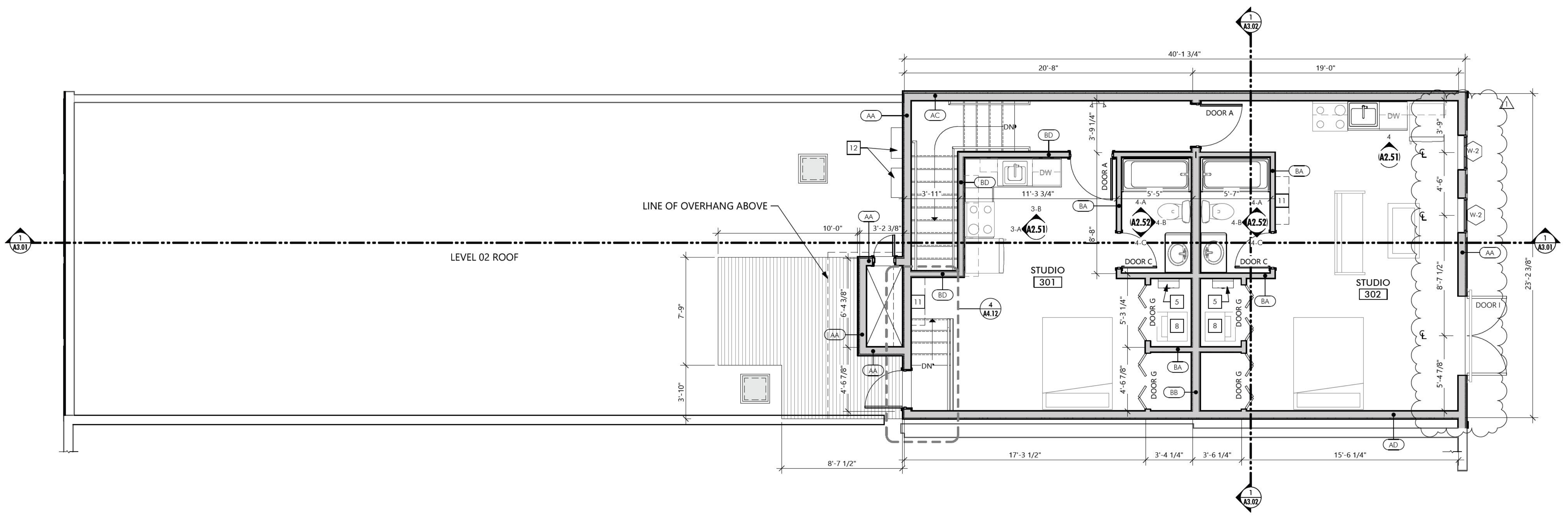

1 LEVEL 03
SCALE: 1/4" = 1'-0"

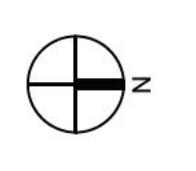

Revised Page
01/30/2026

Permit Number:
BLD-0058-25

ROOF PLAN NOTES:

- 1 EXISTING MEMBRANE ROOF TO REMAIN.
- 2 NEW 60 MIL TPO ROOFING MEMBRANE. SEE A0.22 FOR ASSEMBLY INFORMATION.
- 3 PREFINISHED METAL PARAPET CAP.
- 4 PREFINISHED METAL GUTTER.
- 5 NEW SKYLIGHT.



ADDITION & REMODEL
BRIGGS BUILDING
333 W 1ST AVE ALBANY OR. 97321

REVISIONS:

SHEET:

A1.24

ROOF PLAN

PROJECT # 2024-014

DATE: 3/4/2025

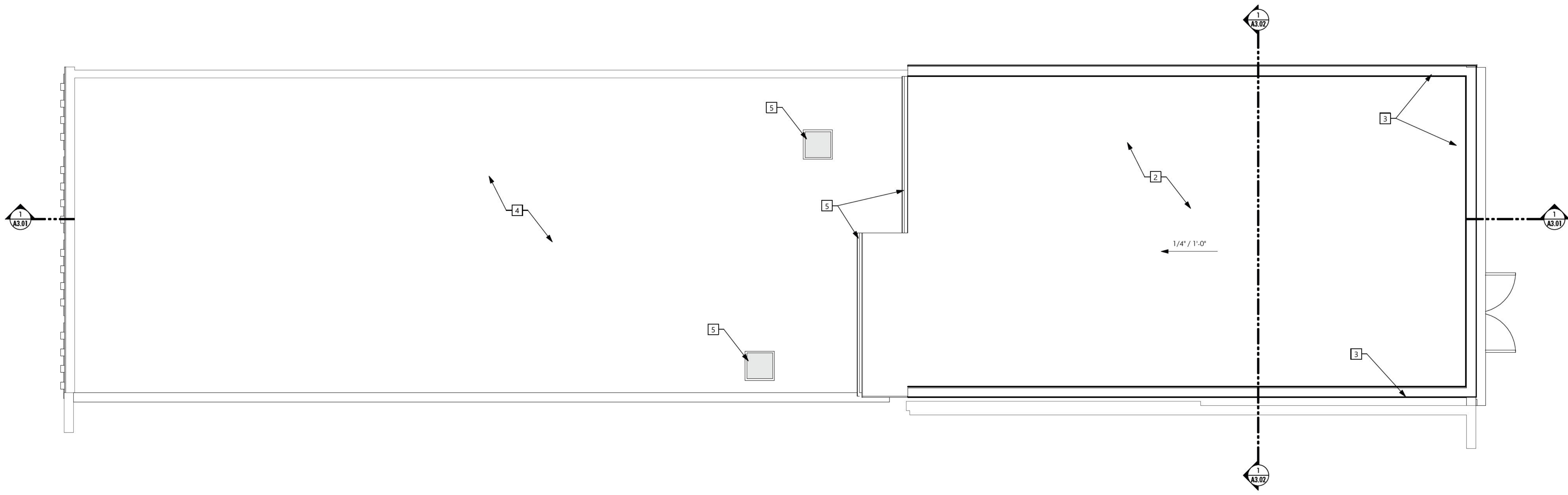



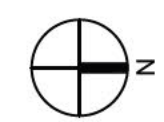



1 ROOF PLAN
SCALE: 1/4" = 1'-0"

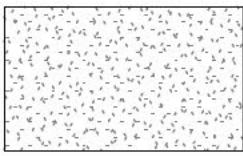

Revised Page
01/30/2026

Permit Number:
BLD-0058-25

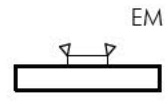
- REFLECTED CEILING PLAN LEGEND:**
-  NEW GYPSUM BOARD CEILING.
 -  COMBINATION CARBON MONOXIDE/SMOKE DETECTOR.
 -  RECESSED LED CAN LIGHT
 -  OUTDOOR SCONCE
 -  24" X 48" SURFACE-MOUNTED LED LIGHT FIXTURE.
 -  EXHAUST FAN. DIRECT VENT TO EXTERIOR.
 -  EMERGENCY EGRESS LIGHTING. ENSURE MINIMUM 1 FOOT CANDLE AT EXIT PATH. ADDITIONAL LIGHTS MAY BE REQUIRED.



ADDITION & REMODEL
BRIGGS BUILDING
333 W 1ST AVE ALBANY OR. 97321

REVISIONS:

SHEET:
A1.61
LEVEL 01 - REFLECTED
CEILING PLAN

PROJECT # 2024-014
DATE: 3/4/2025

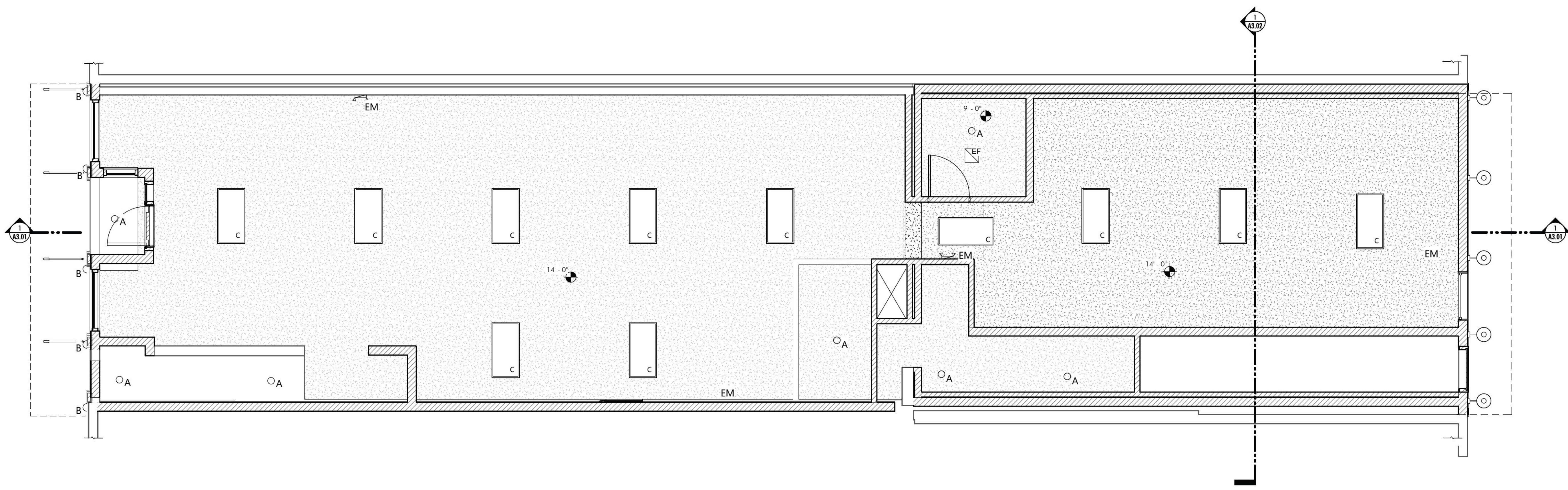







1 LEVEL 01 - REFLECTED CEILING PLAN
SCALE: 1/4" = 1'-0"

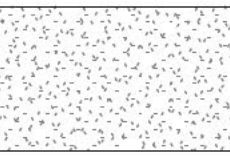

Revised Page
01/30/2026

REFLECTED CEILING PLAN LEGEND:

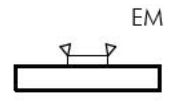
-  NEW GYPSUM BOARD CEILING.
-  COMBINATION CARBON MONOXIDE/SMOKE DETECTOR.
-  RECESSED LED CAN LIGHT
-  OUTDOOR SCONCE
-  24" X 48" SURFACE-MOUNTED LED LIGHT FIXTURE.
-  EXHAUST FAN. DIRECT VENT TO EXTERIOR.
-  EMERGENCY EGRESS LIGHTING. ENSURE MINIMUM 1 FOOT CANDLE AT EXIT PATH. ADDITIONAL LIGHTS MAY BE REQUIRED.

GENERAL PLAN NOTES:

Permit Number: **BLD-0058-25**

1. GENERAL NOTES APPLY TO ALL DRAWINGS.
2. DRAWINGS ARE DIAGRAMMATIC ONLY AND SHOULD NOT BE SCALED. NOTIFY ARCHITECT OF ANY DISCREPANCIES IMMEDIATELY UPON DISCOVERY. OBTAIN CLARIFICATION OF DIMENSIONS OR DISCREPANCIES PRIOR TO PROCEEDING WITH AREA OF REQUIRED WORK.
3. DIMENSIONS ARE TO FACE OF FRAMING. DIMENSIONS STATED AS CLEAR ARE TO FACE OF FINISH.
4. SEE WALL SECTIONS FOR DESCRIPTION OF EXTERIOR WALL MATERIALS.
5. ALL INTERIOR PARTITIONS TO RECEIVE GLASS FIBER INSULATION, FULL HEIGHT.
6. COORDINATE LOCATION OF RECESSED OR SEMI-RECESSED ITEMS TO AVOID BACK TO BACK INSTALLATION AND TO REDUCE NOISE TRANSFER THROUGH PARTITIONS.
7. INSTALL WALL BACKING FOR ALL WALL MOUNTED ITEMS, INCLUDING BUT NOT LIMITED TO THE FOLLOWING: DOOR STOPS, FIXTURES, WALL CABINETS, SHELVING, COUNTERS, TOILET ACCESSORIES, SECURITY EQUIPMENT, TACK BOARDS AND MARKER BOARDS, HAND RAILS AND WINDOW COVERING TRACKS.
8. SEPARATE AREAS IN WHICH WORK IS BEING CONDUCTED FROM OTHER AREAS THAT ARE STILL OCCUPIED.
 - A. PROVIDE, ERECT, AND MAINTAIN TEMPORARY DUSTPROOF PARTITIONS OF SUITABLE CONSTRUCTION IN LOCATIONS INDICATED ON DRAWINGS OR AS DIRECTED.
9. PROTECT EXISTING WORK TO REMAIN.
 - A. PREVENT MOVEMENT OF STRUCTURE. PROVIDE SHORING AND BRACING IF NECESSARY.
 - B. PERFORM CUTTING TO ACCOMPLISH REMOVALS NEATLY AND AS SPECIFIED FOR CUTTING NEW WORK.IG NEW WORK.
 - C. REPAIR ADJACENT CONSTRUCTION AND FINISHES DAMAGED DURING REMOVAL WORK.
 - D. PATCH AS SPECIFIED FOR PATCHING NEW WORK.
10. REMOVE DEBRIS, JUNK, AND TRASH FROM SITE.
11. REMOVE FROM SITE ALL MATERIALS NOT TO BE REUSED ON SITE; DO NOT BURN OR BURY.
12. LEAVE SITE IN CLEAN CONDITION, READY FOR SUBSEQUENT WORK.
13. CLEAN UP SPILLAGE AND WIND-BLOWN DEBRIS FROM PUBLIC AND PRIVATE LANDS.
14. WORK SHOWN ON THESE DRAWINGS IS TO BE SUPPLIED, FURNISHED, CONSTRUCTED, INSTALLED ALL AS PER THE GENERAL CONDITIONS AND THE SPECIFICATIONS, EXCEPTIONS AS DESCRIBED BY THE FOLLOWING ABBREVIATIONS:
 - A. CFCI CONTRACTOR FURNISHED - CONTRACTOR INSTALLED.
 - B. OFCI OWNER FURNISHED - CONTRACTOR INSTALLED.
 - C. OFOI OWNER FURNISHED - OWNER INSTALLED.
 - D. NIC OR N.I.C. NOT IN CONTRACT OR NOT A PART OF THIS CONTRACT.

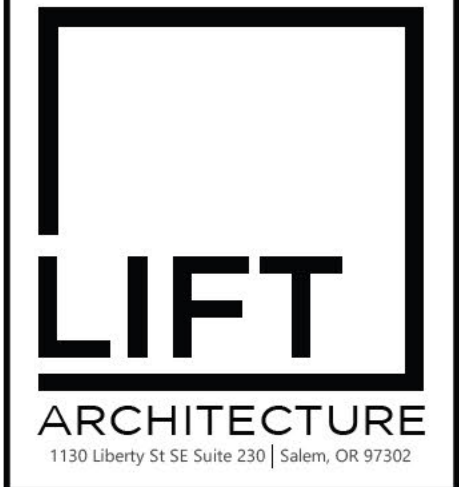

ADDITION & REMODEL
BRIGGS BUILDING
333 W 1ST AVE ALBANY OR. 97321

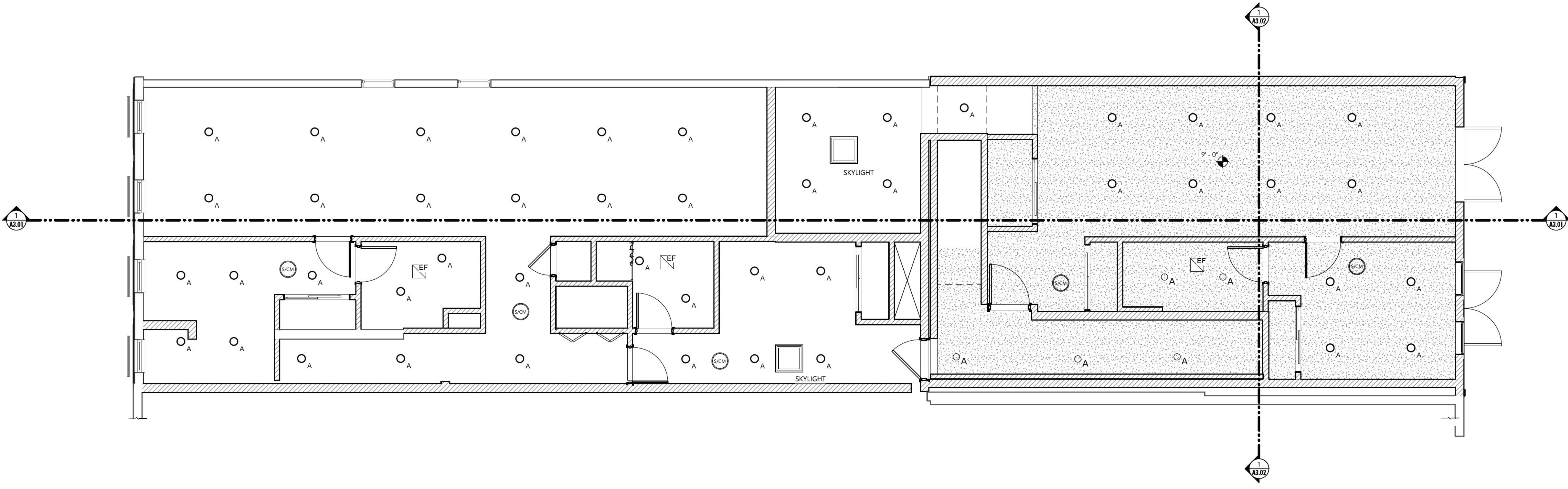

1 LEVEL 02 - REFLECTED CEILING PLAN
SCALE: 1/4" = 1'-0"

REVISIONS:







SHEET:
A1.62
LEVEL 02 - REFLECTED CEILING PLAN

PROJECT # 2024-014
DATE: 3/4/2025

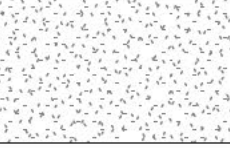

Revised Page
01/30/2026

REFLECTED CEILING PLAN LEGEND:

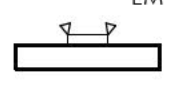
-  NEW GYPSUM BOARD CEILING.
-  COMBINATION CARBON MONOXIDE/SMOKE DETECTOR.
-  RECESSED LED CAN LIGHT
-  OUTDOOR SCONCE
-  24" X 48" SURFACE-MOUNTED LED LIGHT FIXTURE.
-  EXHAUST FAN. DIRECT VENT TO EXTERIOR.
-  EMERGENCY EGRESS LIGHTING. ENSURE MINIMUM 1 FOOT CANDLE AT EXIT PATH. ADDITIONAL LIGHTS MAY BE REQUIRED.

GENERAL PLAN NOTES:

Permit Number:
BLD-0058-25

1. GENERAL NOTES APPLY TO ALL DRAWINGS.
2. DRAWINGS ARE DIAGRAMMATIC ONLY AND SHOULD NOT BE SCALED. NOTIFY ARCHITECT OF ANY DISCREPANCIES IMMEDIATELY UPON DISCOVERY. OBTAIN CLARIFICATION OF DIMENSIONS OR DISCREPANCIES PRIOR TO PROCEEDING WITH AREA OF REQUIRED WORK.
3. DIMENSIONS ARE TO FACE OF FRAMING. DIMENSIONS STATED AS CLEAR ARE TO FACE OF FINISH.
4. SEE WALL SECTIONS FOR DESCRIPTION OF EXTERIOR WALL MATERIALS.
5. ALL INTERIOR PARTITIONS TO RECEIVE GLASS FIBER INSULATION, FULL HEIGHT.
6. COORDINATE LOCATION OF RECESSED OR SEMI-RECESSED ITEMS TO AVOID BACK TO BACK INSTALLATION AND TO REDUCE NOISE TRANSFER THROUGH PARTITIONS.
7. INSTALL WALL BACKING FOR ALL WALL MOUNTED ITEMS, INCLUDING BUT NOT LIMITED TO THE FOLLOWING: DOOR STOPS, FIXTURES, WALL CABINETS, SHELVING, COUNTERS, TOILET ACCESSORIES, SECURITY EQUIPMENT, TACK BOARDS AND MARKER BOARDS, HAND RAILS AND WINDOW COVERING TRACKS.
8. SEPARATE AREAS IN WHICH WORK IS BEING CONDUCTED FROM OTHER AREAS THAT ARE STILL OCCUPIED.
 - A. PROVIDE, ERECT, AND MAINTAIN TEMPORARY DUSTPROOF PARTITIONS OF SUITABLE CONSTRUCTION IN LOCATIONS INDICATED ON DRAWINGS OR AS DIRECTED.
9. PROTECT EXISTING WORK TO REMAIN.
 - A. PREVENT MOVEMENT OF STRUCTURE. PROVIDE SHORING AND BRACING IF NECESSARY.
 - B. PERFORM CUTTING TO ACCOMPLISH REMOVALS NEATLY AND AS SPECIFIED FOR CUTTING NEW WORK.IG NEW WORK.
 - C. REPAIR ADJACENT CONSTRUCTION AND FINISHES DAMAGED DURING REMOVAL WORK.
 - D. PATCH AS SPECIFIED FOR PATCHING NEW WORK.
10. REMOVE DEBRIS, JUNK, AND TRASH FROM SITE.
11. REMOVE FROM SITE ALL MATERIALS NOT TO BE REUSED ON SITE; DO NOT BURN OR BURY.
12. LEAVE SITE IN CLEAN CONDITION, READY FOR SUBSEQUENT WORK.
13. CLEAN UP SPILLAGE AND WIND-BLOWN DEBRIS FROM PUBLIC AND PRIVATE LANDS.
14. WORK SHOWN ON THESE DRAWINGS IS TO BE SUPPLIED, FURNISHED, CONSTRUCTED, INSTALLED ALL AS PER THE GENERAL CONDITIONS AND THE SPECIFICATIONS, EXCEPTIONS AS DESCRIBED BY THE FOLLOWING ABBREVIATIONS:
 - A. CFCI - CONTRACTOR FURNISHED - CONTRACTOR INSTALLED.
 - B. OFCI - OWNER FURNISHED - CONTRACTOR INSTALLED.
 - C. OFOI - OWNER FURNISHED - OWNER INSTALLED.
 - D. NIC OR N.I.C. - NOT IN CONTRACT OR NOT A PART OF THIS CONTRACT.

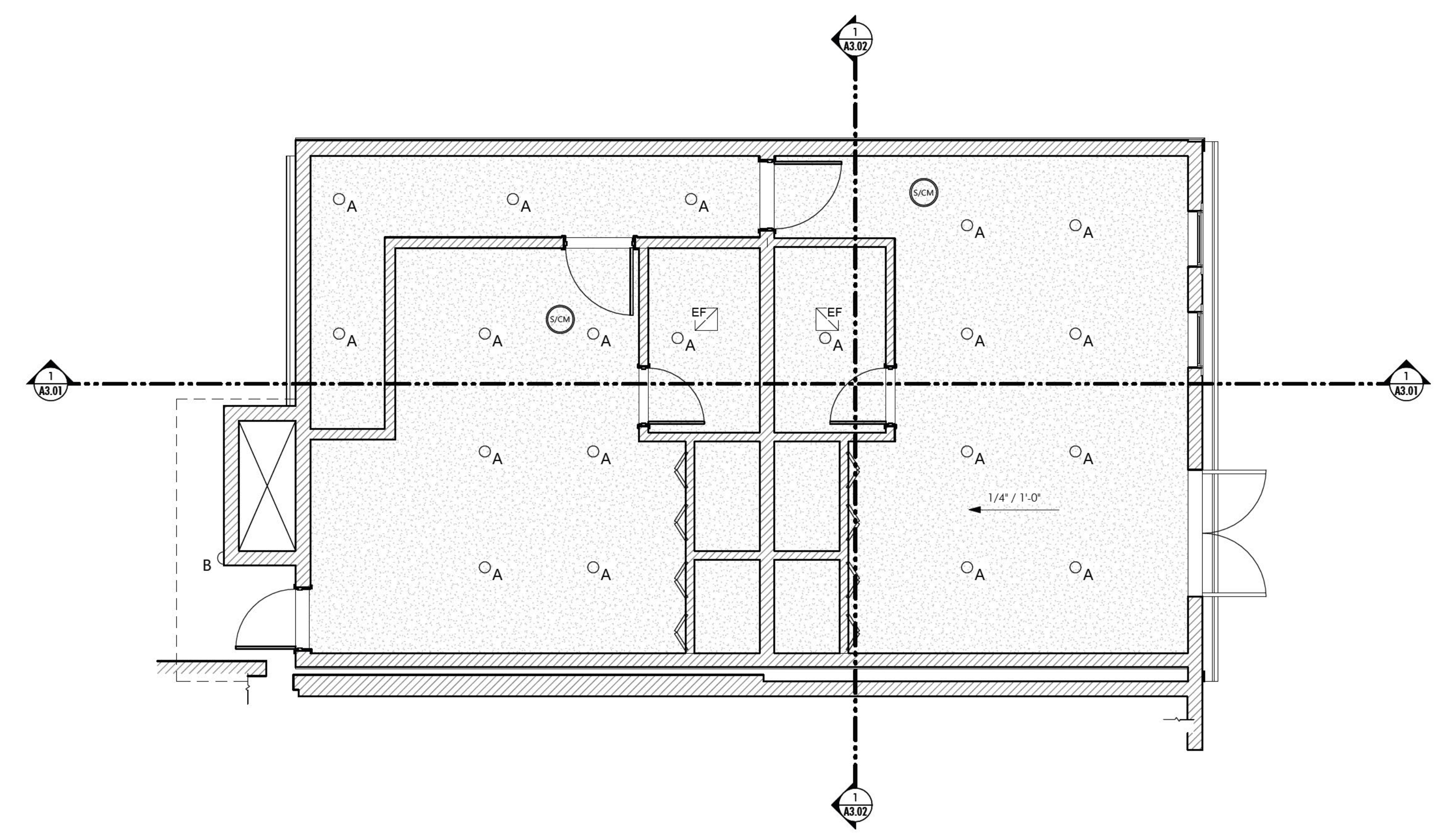

ADDITION & REMODEL
BRIGGS BUILDING
 333 W 1ST AVE ALBANY OR. 97321

REVISIONS:

SHEET:
A1.63
 LEVEL 03 - REFLECTED
 CEILING PLAN

PROJECT # 2024-014
 DATE: 3/4/2025

1 LEVEL 03 - REFLECTED CEILING PLAN
 SCALE: 1/4" = 1'-0"



Permit Number:
BLD-0056-25

NO.	DESCRIPTION
1	NEW WOOD CORNICE WITH DECORATIVE BRACKETS, CORBELS, AND PANELING.
2	EXISTING WINDOWS ON 2ND FLOOR TO BE REPAIRED AS NEEDED, NEW WOOD OR POLY-ASH TRIM ADDED.
3	NEW POLY-ASH TRIM BANDING.
4	NEW FABRIC AWNING.
5	REMOVE EXISTING NON-HISTORIC WINDOWS, DOORS, AND FACADE AT GROUND LEVEL TO REPAIR STRUCTURAL ELEMENTS. REPLACE WITH NEW WOOD STOREFRONTS AND CLERESTORIES TO RECREATE HISTORICAL INTENT.
6	WOOD OR POLY-ASH TRIM ADDED TO DECORATIVE COLUMNS AND STOREFRONT BASE TO RECREATE HISTORICAL INTENT.
7	NEW PAINTED FIBER CEMENT T&G SIDING TO MATCH EXISTING SIDE FACADE WOOD SIDING IN APPEARANCE AND TEXTURE.
8	NEW FLASHING AT PARAPET AND NEW PAINT FOR EXISTING SIDE FACADE.
9	EXISTING NON-HISTORIC ONE-STORY BACK BUILDING ADDITION TO BE DEMOLISHED AND REPLACED WITH NEW THREE-STORY ADDITION TO COMPLIMENT, BUT NOT MIMIC, THE HISTORIC STRUCTURE.
10	NEW ALUMINUM CORNICE.
11	NEW VINYL WINDOWS.
12	NEW PAINTED FIBER CEMENT SIDING TO APPROXIMATE EXISTING SIDE FACADE WOOD SIDING IN APPEARANCE AND TEXTURE.
13	NEW POLY-ASH CORNER TRIM.
14	NEW WOOD STOREFRONT.
15	NEW HOLLOW METAL ACCESS DOOR.
16	NEW CONCRETE STAIRS WITH METAL STAIR RAILING.
17	NEW WOOD DOOR.
18	MINIMUM 42" H GUARDRAIL AT BALCONIES.
19	WALL-MOUNTED ELECTRICAL SWITCH GEAR/METER PACKS.
20	FUTURE TYPE I HOOD EXHAUST FAN. LOCATION SHOWN FOR CLEARANCE REFERENCE ONLY.
21	WALL-MOUNTED EXTERIOR LIGHT FIXTURE, MOUNTED AT 8'-4" ABOVE CONCRETE WALKWAY.
22	FABRIC AWNING BY OTHERS.

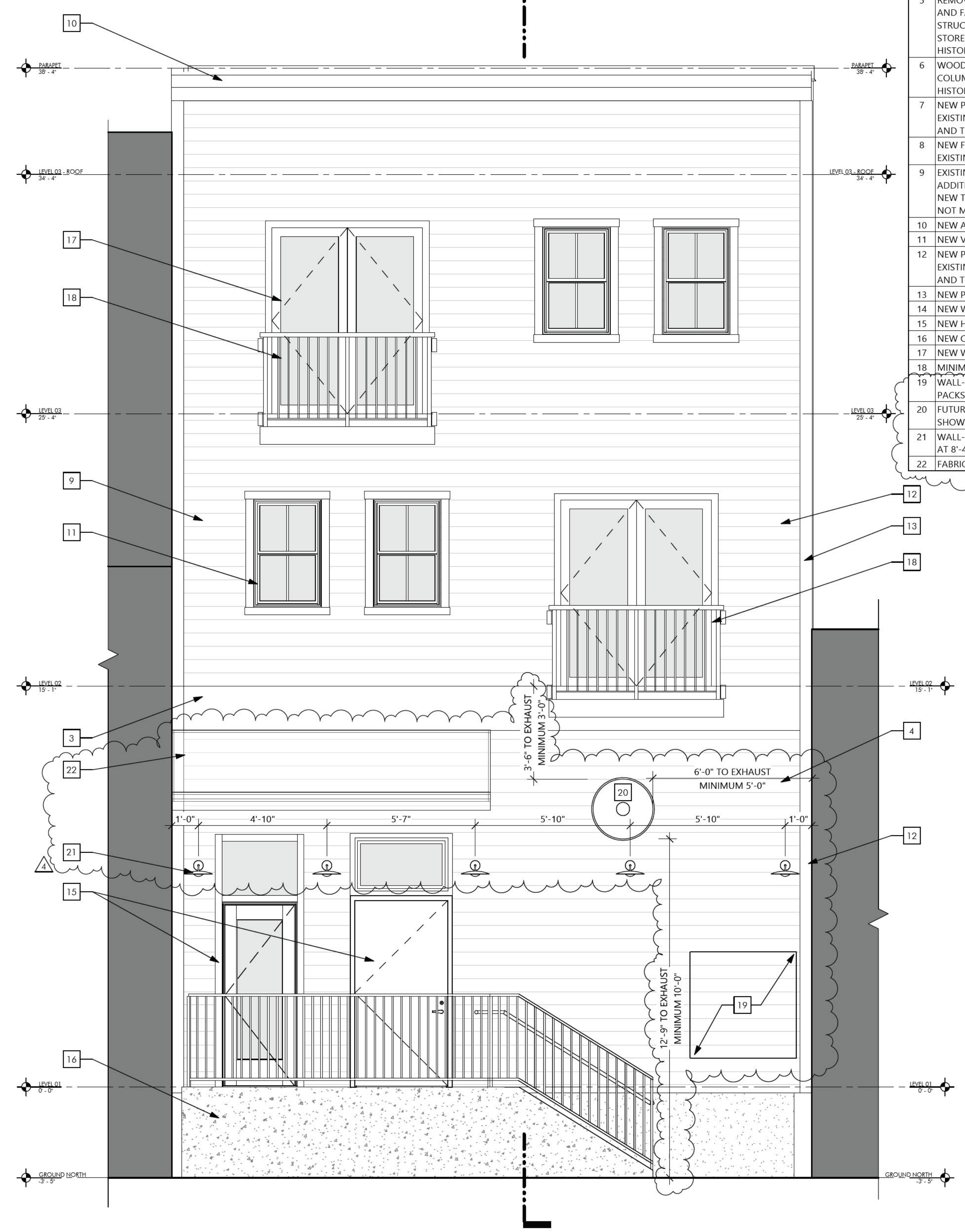
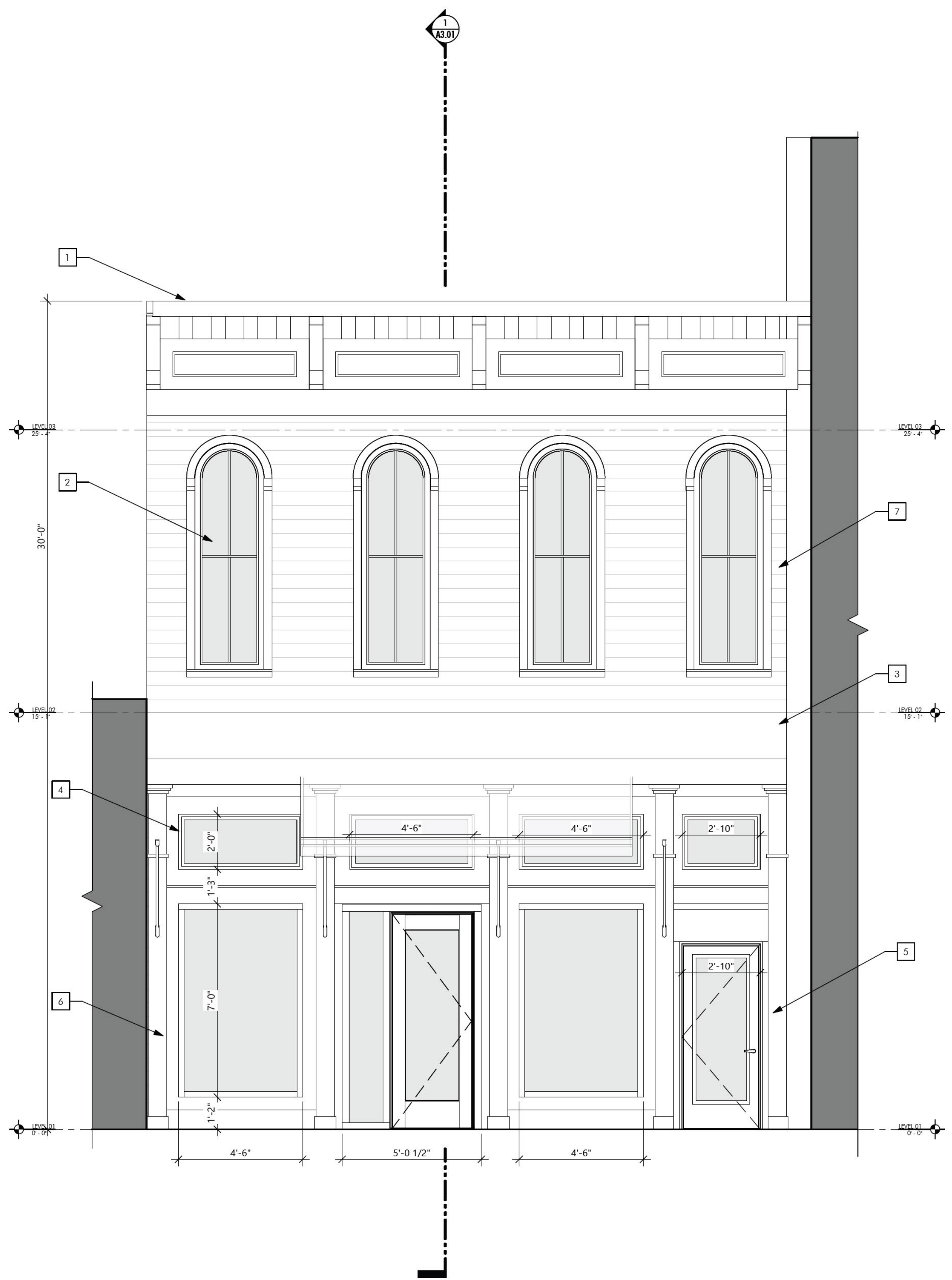

1 PROPOSED SOUTH ELEVATION
SCALE: 3/8" = 1'-0"

2 PROPOSED NORTH ELEVATION
SCALE: 3/8" = 1'-0"



ADDITION & REMODEL
BRIGGS BUILDING
333 W 1ST AVE ALBANY OR. 97321

REVISIONS:
4 1/28/2026 Sprinklers/Elevations

SHEET:
A2.11
PROPOSED ELEVATIONS

PROJECT # 2024-014
DATE: 3/4/2025

Permit Number: BLD-0058-25

KITCHEN NOTES

NO.	DESCRIPTION
1	SINGLE BASIN KITCHEN SINK WITH FAUCET (LEVER TYPE HANDLES) AND FOOD DISPOSAL. ENSURE SUPPLY AND DRAIN PIPES AND FOOD DISPOSAL ARE CONFIGURED TO PROTECT AGAINST CONTACT. VERIFY MAKE AND MODEL WITH OWNER.
2	STANDARD HEIGHT DISHWASHER. VERIFY MAKE AND MODEL WITH OWNER.
3	REFRIGERATOR. VERIFY MAKE AND MODEL WITH OWNER.
4	ELECTRIC RANGE. VERIFY MAKE AND MODEL WITH OWNER.
5	FILLER STRIP. SIZE TO FILL SPACE AS SHOWN.
6	RANGE HOOD WITH EXHAUST FAN. VERIFY MAKE AND MODEL WITH OWNER.
7	COUNTERTOP, OVERHANG EXPOSED EDGES BY 1 1/2" UNLESS NOTED OTHERWISE.
8	4" BACKSPLASH/SIDESPLASH TO MATCH COUNTERTOP.
9	CONTINUOUS TOEKICK.
10	SIDE PANEL TO MATCH CABINET DEPTH AND HEIGHT. 3/4" WITH 1" FACE FINISHED BOTH SIDES.

LIFT
ARCHITECTURE
1130 Liberty St SE Suite 230 | Salem, OR 97302

REGISTERED ARCHITECT
MATTHEW D. JOHNSON
SALEM, OREGON 13288
STATE OF OREGON

ADDITION & REMODEL
BRIGGS BUILDING
333 W 1ST AVE ALBANY OR. 97321

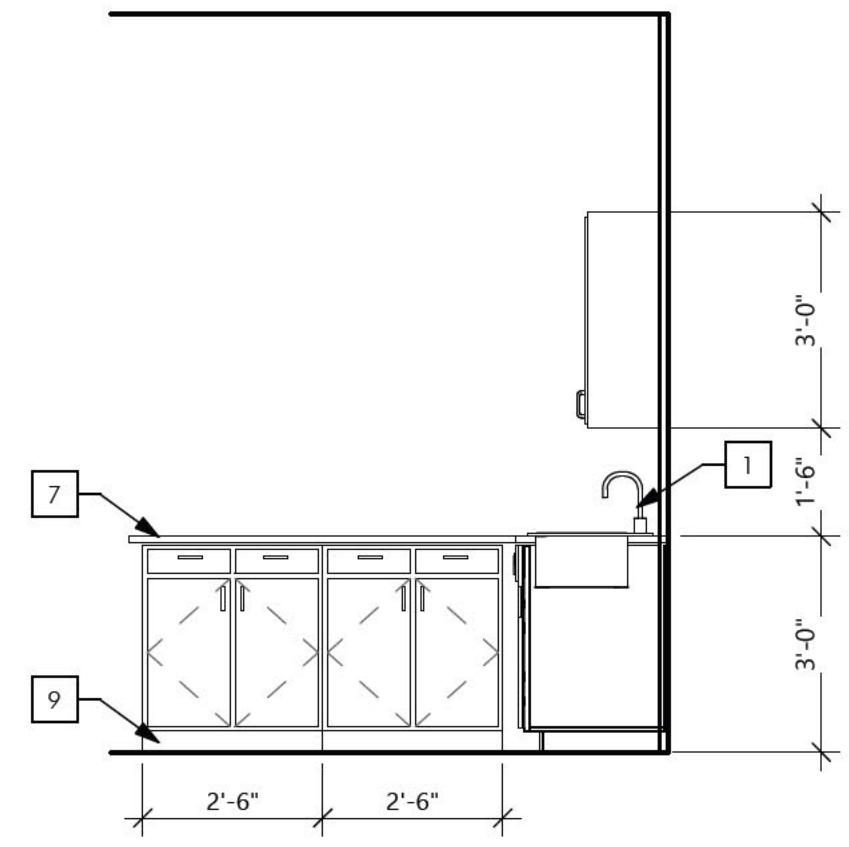

1-A

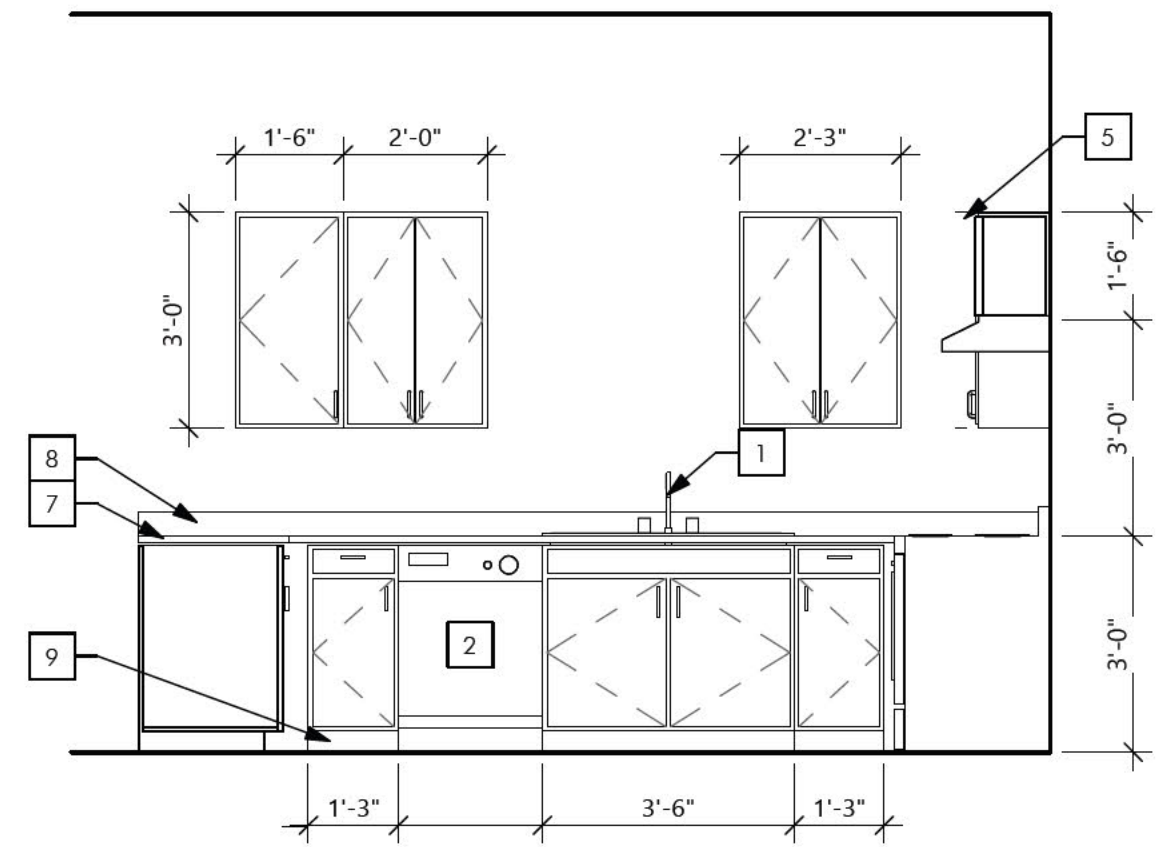

1-B

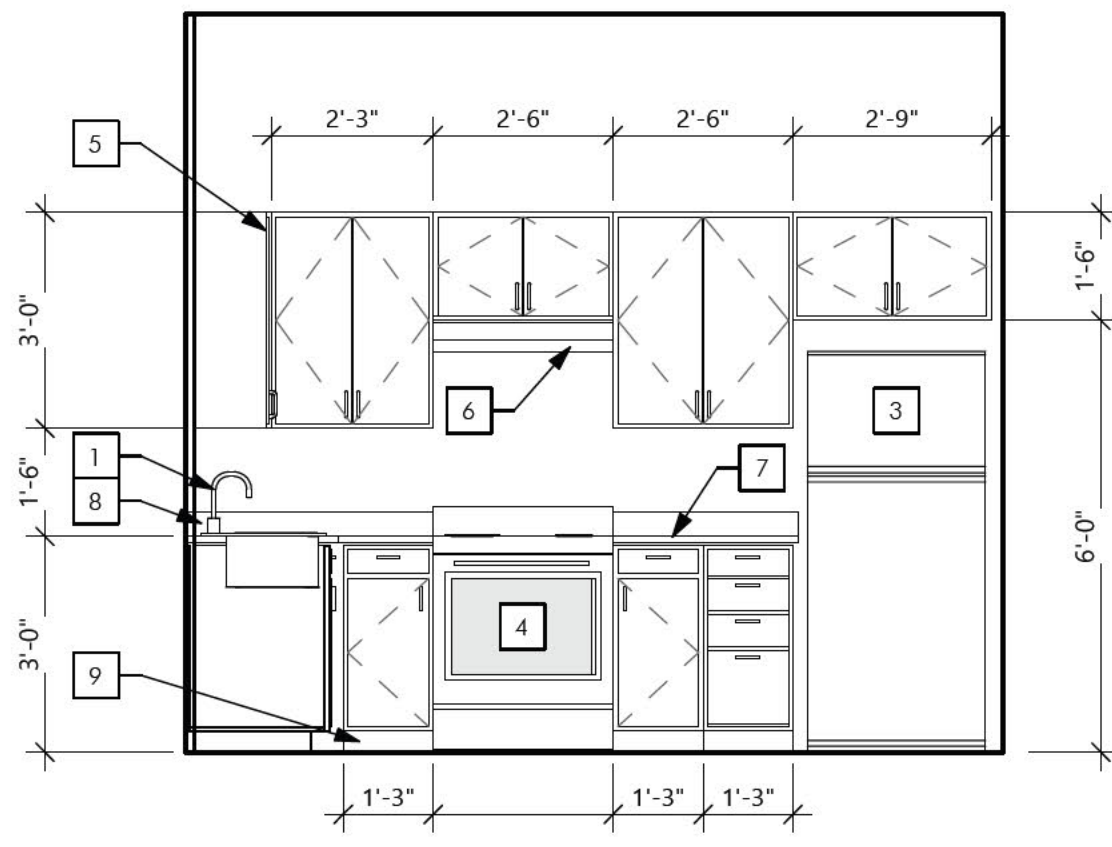

1-C

1 201 KITCHEN
SCALE: 1/4" = 1'-0"

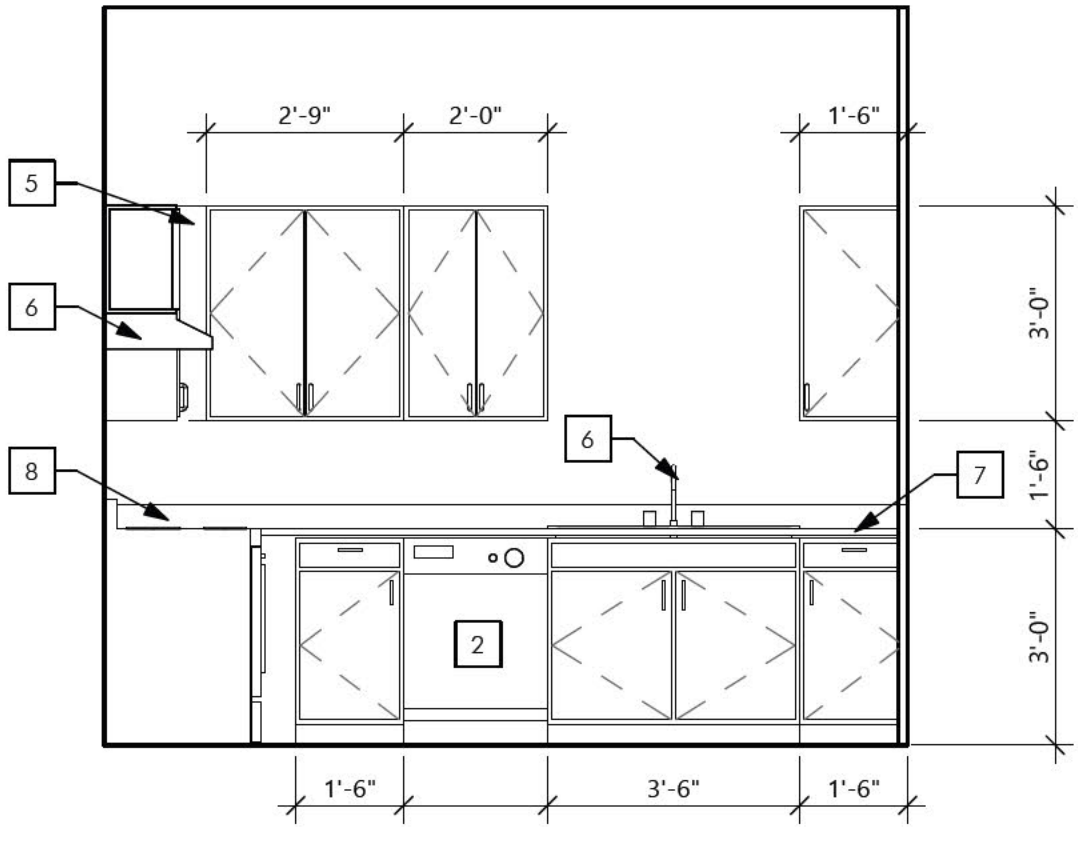

2-A

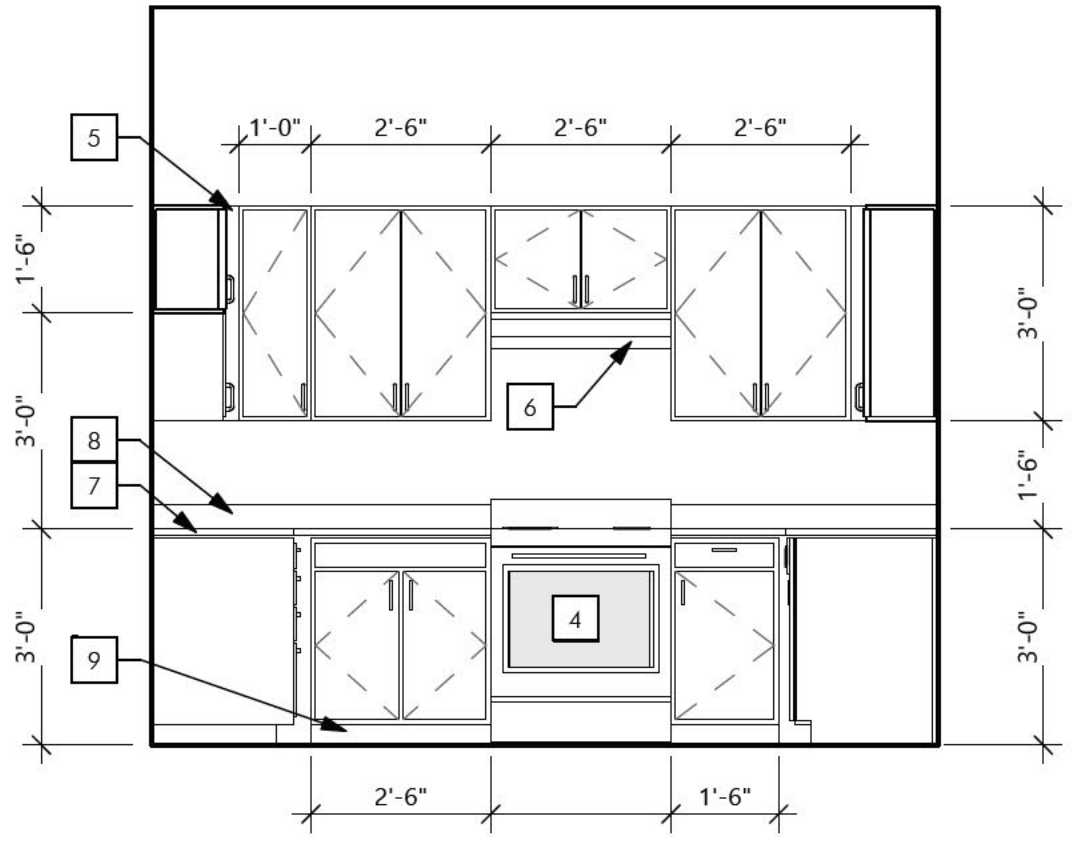

2-B

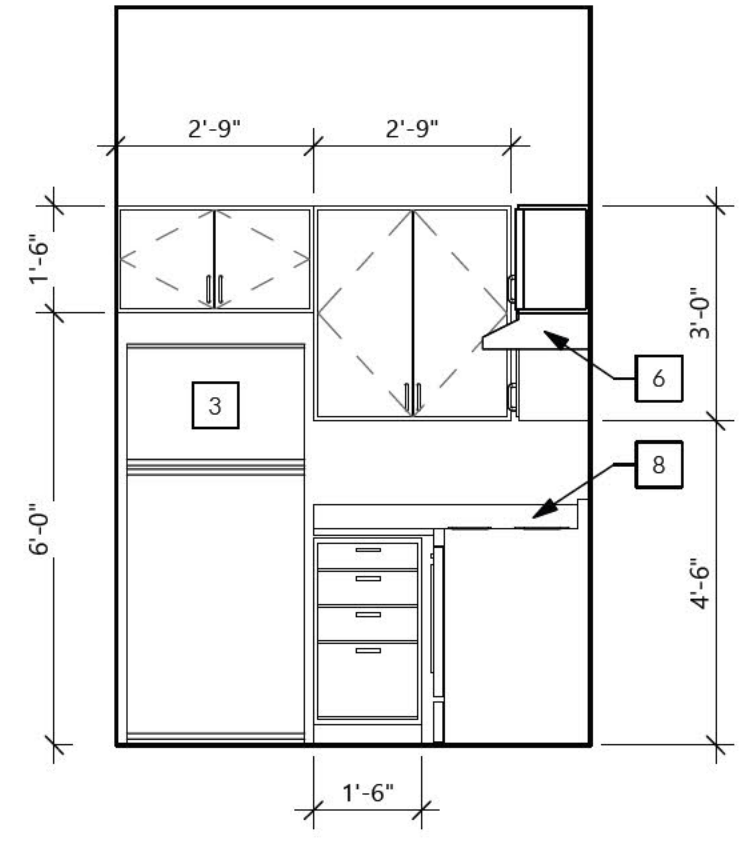

2-C

2 202 KITCHEN
SCALE: 1/4" = 1'-0"

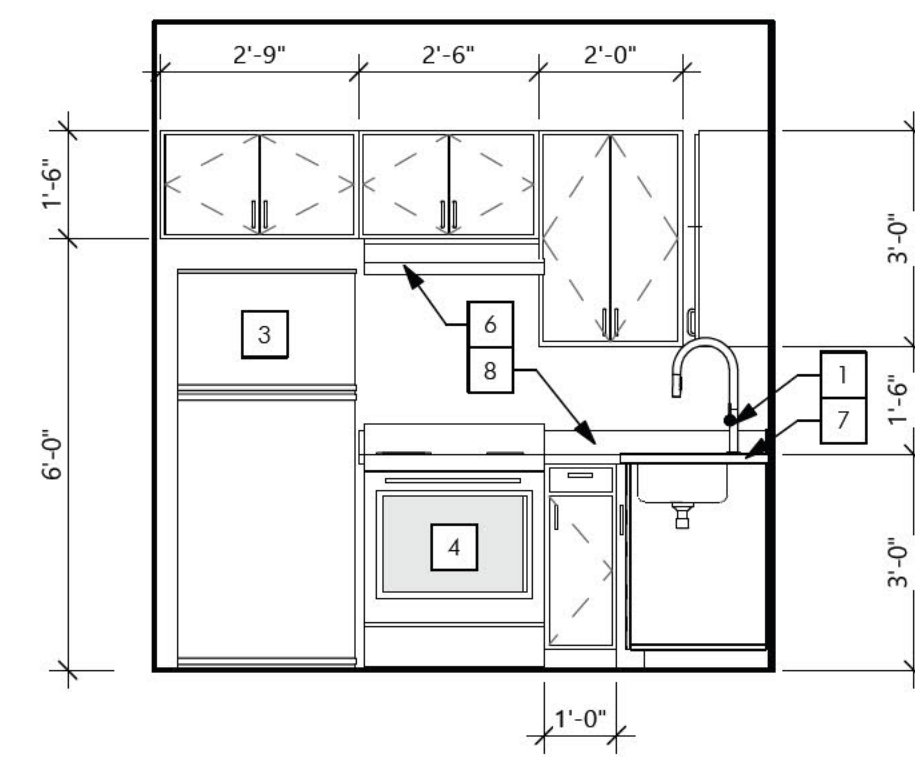

3-A

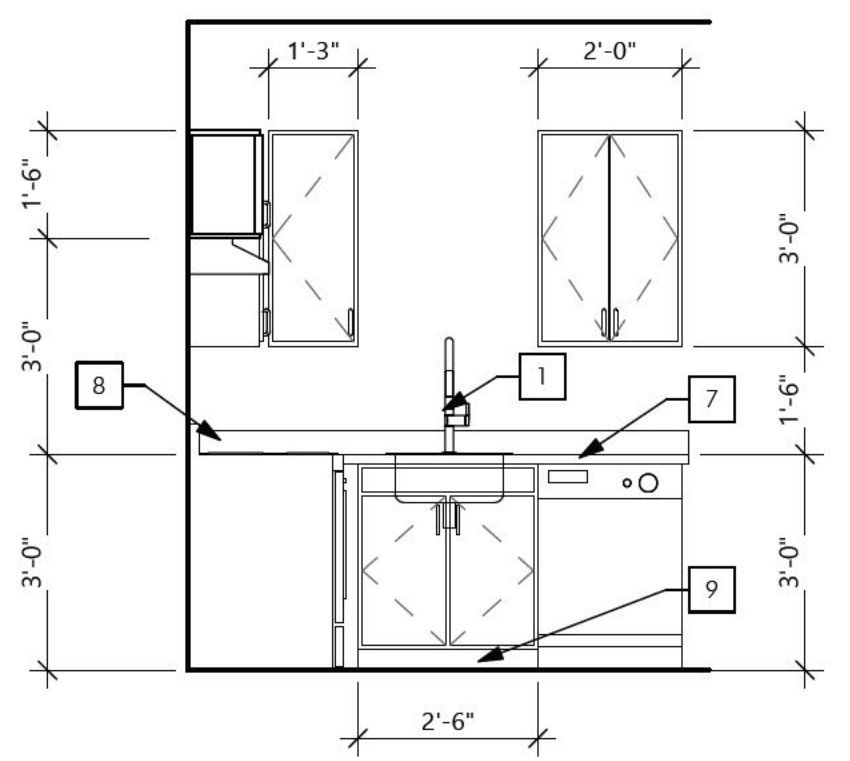

3-B

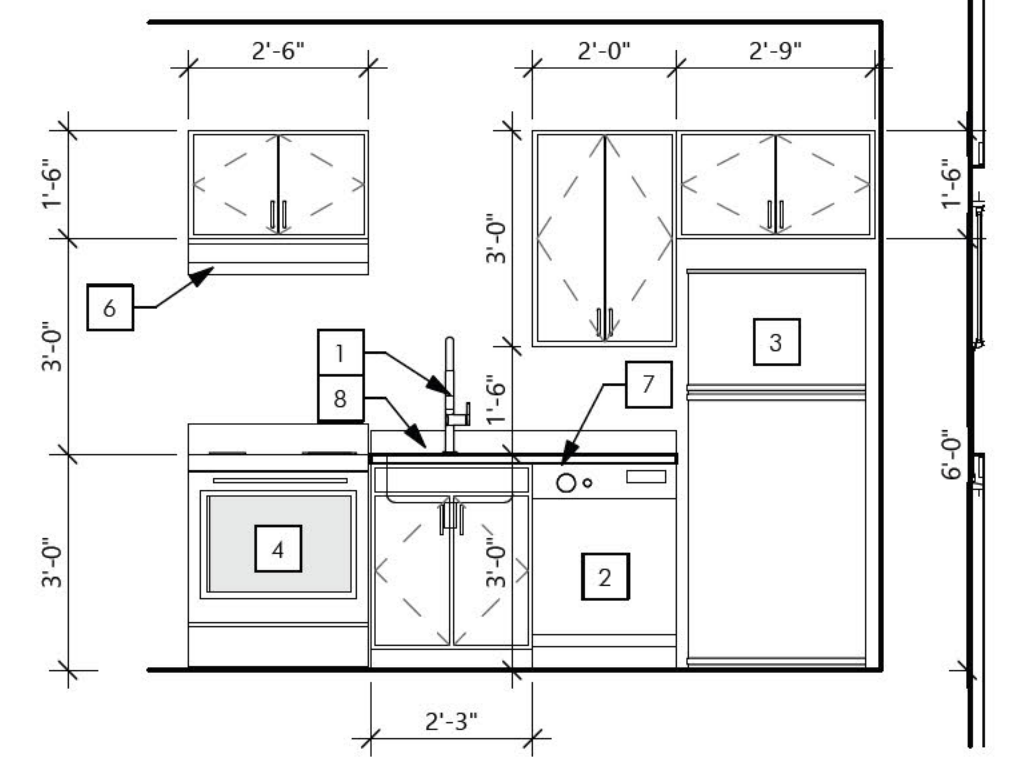

4 302 KITCHEN
SCALE: 3/8" = 1'-0"

REVISIONS:

SHEET:
A2.51
KITCHEN ELEVATIONS

PROJECT # 2024-014
DATE: 3/4/2025

Permit Number: BLD-0058-25	
BATHROOM NOTES	
NO.	DESCRIPTION
1	PRE-FABRICATED FIBERGLASS TUB SURROUND.
2	PRE-FABRICATED FIBERGLASS SHOWER SURROUND.
3	TOILET, ACCESSIBLE.
4	BATHROOM SINK WITH FAUCET (LEVER TYPE HANDLES). 2'-10" MAXIMUM HEIGHT FROM FLOOR TO TOP OF SINK RIM.
5	FRAMELESS MIRROR. SIZE AS SHOWN IN ELEVATIONS. VERIFY IN FIELD.
6	SHOWER CURTAIN ROD. PROVIDE SOLID BACKING.
7	LIGHTING AS SELECTED.
8	PROVIDE BLOCKING AT SHOWERS PER G2.02/G2.03.
9	24" TOWEL BAR @ 48" AFF UNLESS OTHERWISE NOTED. PROVIDED SOLID BACKING.
10	CONTINUOUS TOEKICK.
11	PROVIDE BLOCKING FOR FUTURE INSTALLATION OF REAR, SIDE, AND VERTICAL GRAB BARS.
12	CASEWORK AT VANITY IN TYPE A/B UNITS TO BE REMOVABLE. EXTEND WALL AND FLOOR FINISHES BEHIND/BENEATH CASEWORK.
13	BASEBOARD TRIM.
14	BUILT IN CASEWORK.

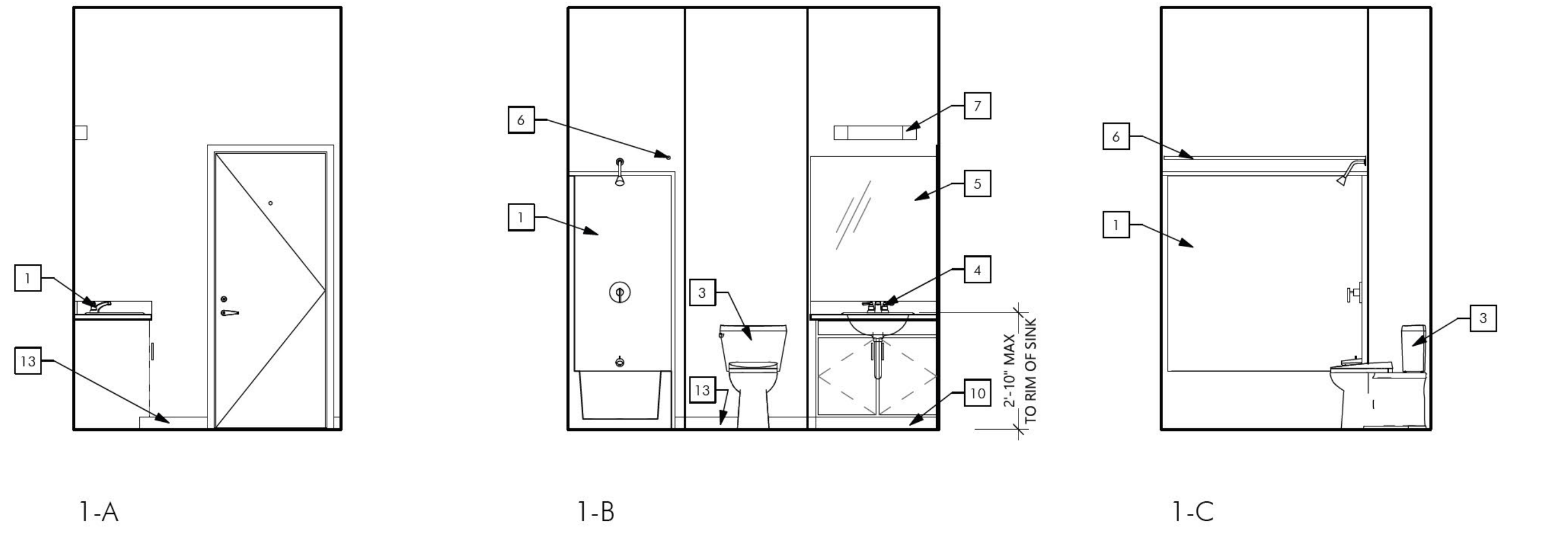

1 201 BATHROOM 1
SCALE: 1/4" = 1'-0"

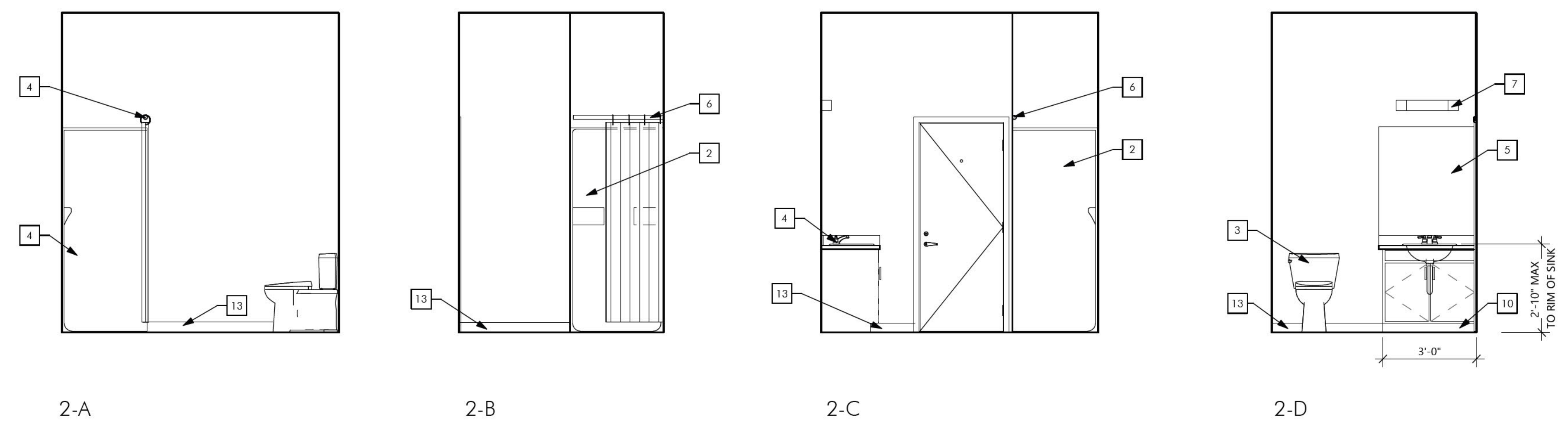

2 201 BATHROOM 2
SCALE: 1/4" = 1'-0"

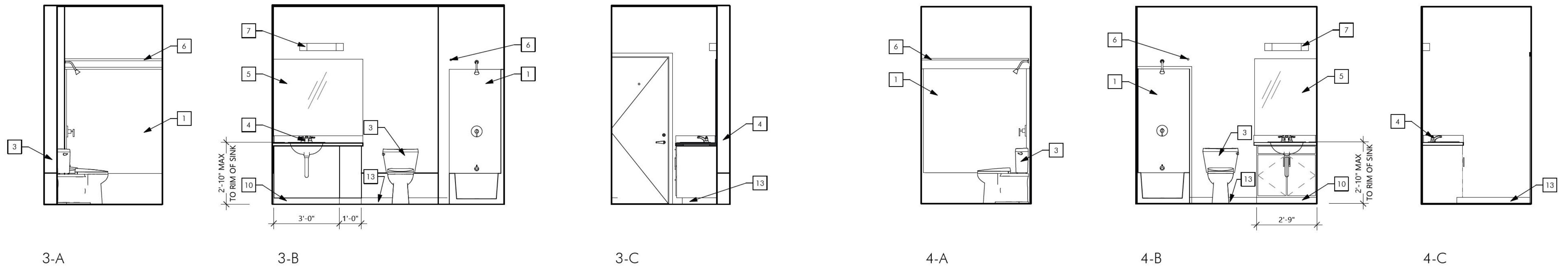

3 202 BATHROOM
SCALE: 1/4" = 1'-0"

4 301/302 BATHROOM
SCALE: 1/4" = 1'-0"

ADDITION & REMODEL
BRIGGS BUILDING
 333 W 1ST AVE ALBANY OR. 97321

REVISIONS:

SHEET:
A2.52
BATHROOM
ELEVATIONS

PROJECT # 2024-014
DATE: 3/4/2025

Revised Page
01/30/2026

Permit Number:
BLD-0058-25

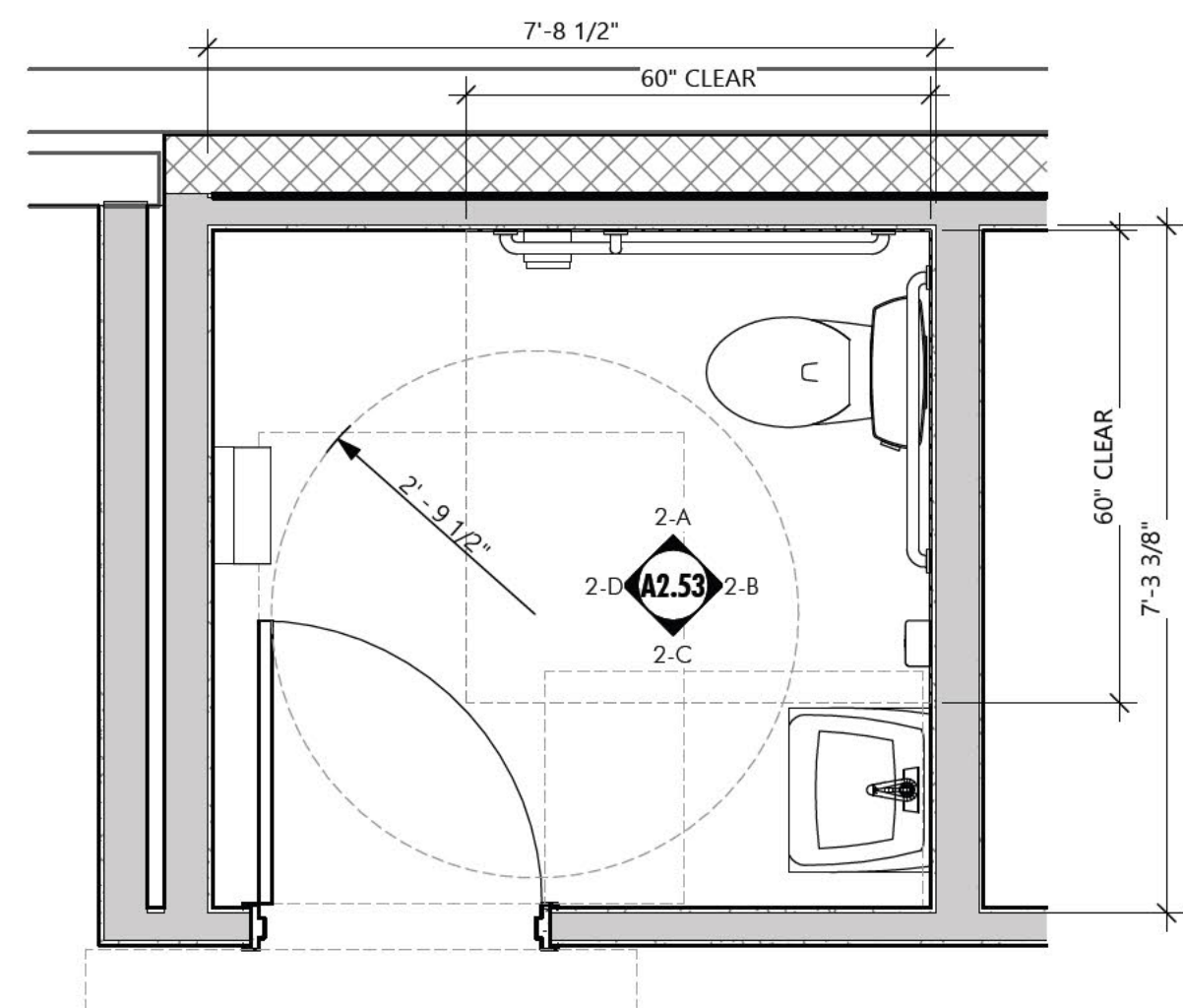

1 RESTROOM DETAIL PLAN
SCALE: 1/2" = 1'-0"

TOILET NOTES/ACCESSORIES:

- 1 TOILET TISSUE DISPENSER.
- 2 HANDS FREE PAPER TOWEL DISPENSER.
- 3 2'-0" X 3'-0" FRAMED MIRROR.
- 4 WALL-MOUNTED SOAP DISPENSER.
- 5 HANDICAPPED TOILET PLAN AND ELEVATION WITH GRAB BAR MOUNTING LOCATIONS.
- 6 WRAP PIPES UNDER SINK.
- 7 IMPERVIOUS WALL COVERING UP TO 4'-0" MIN.

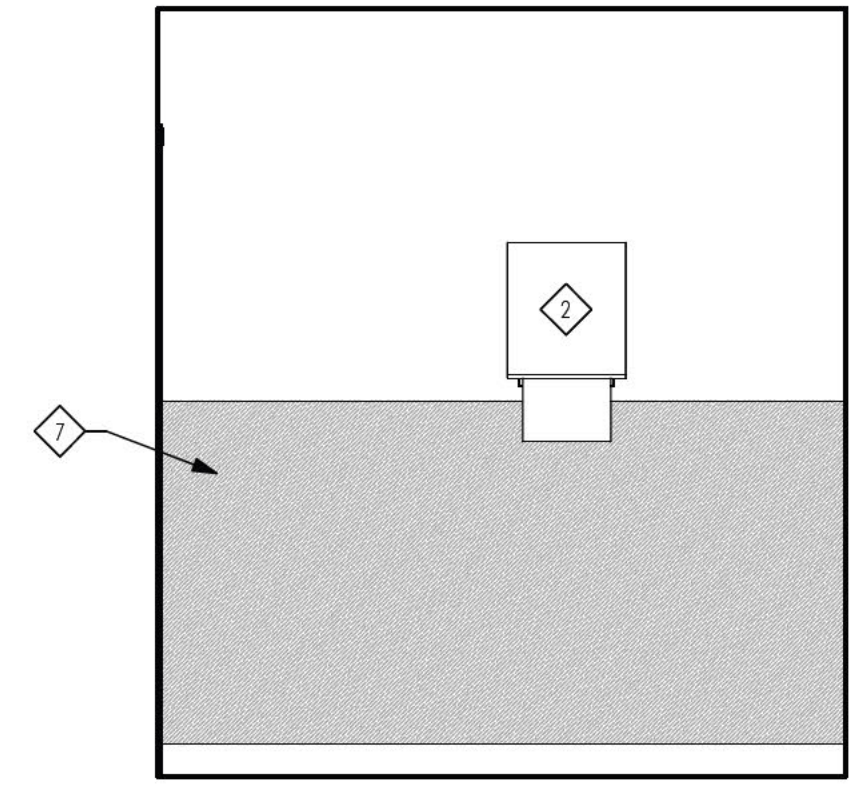
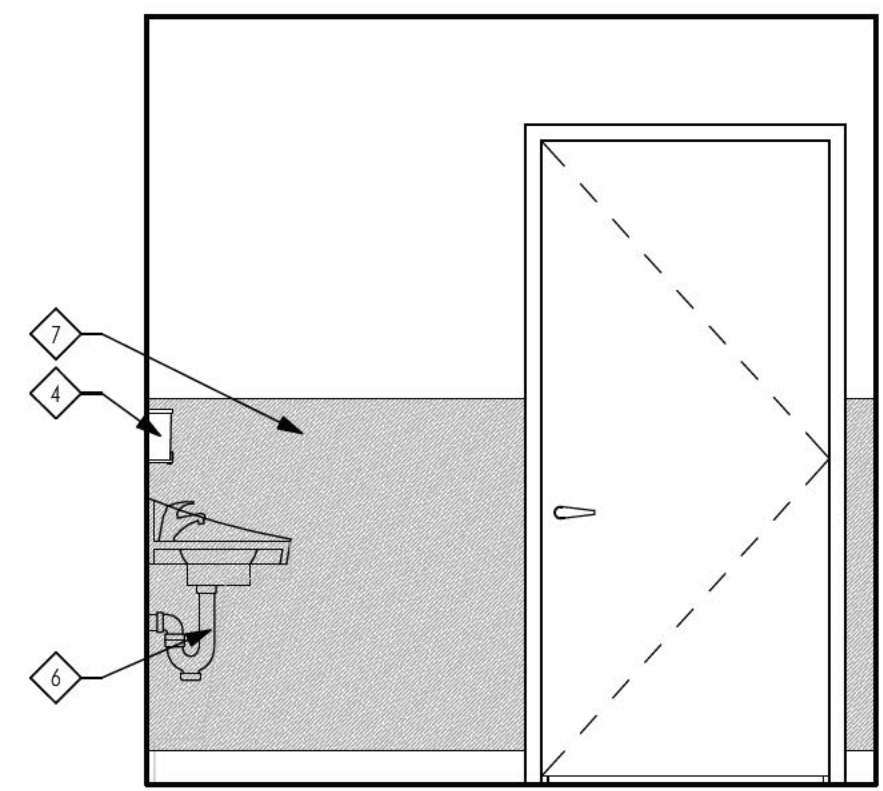
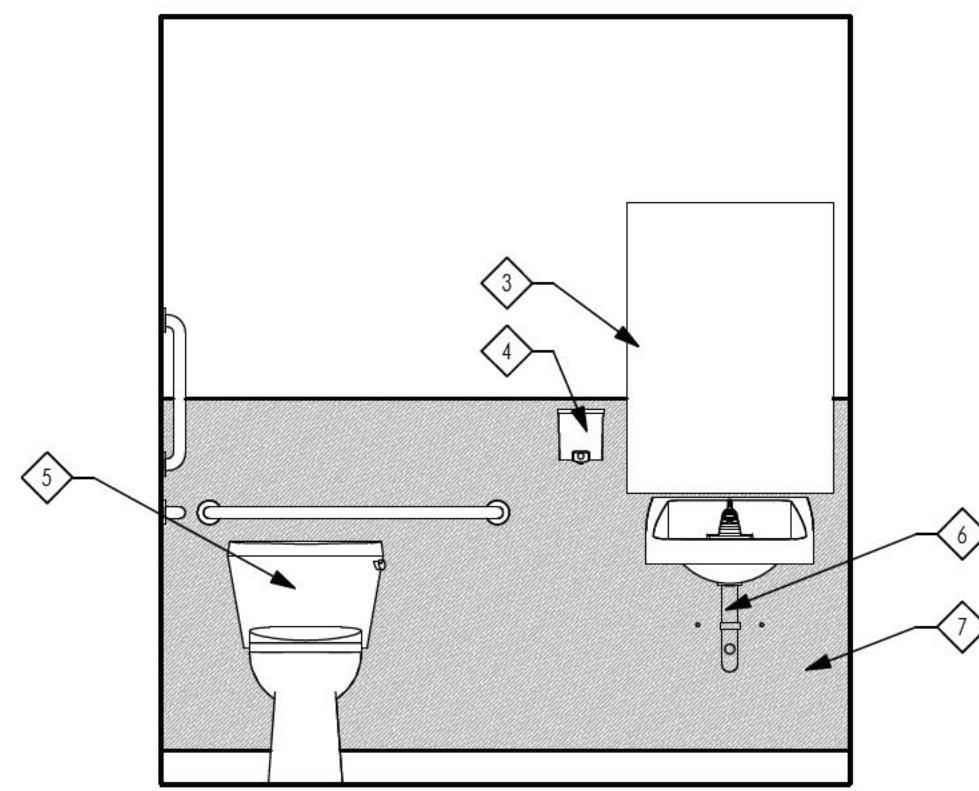
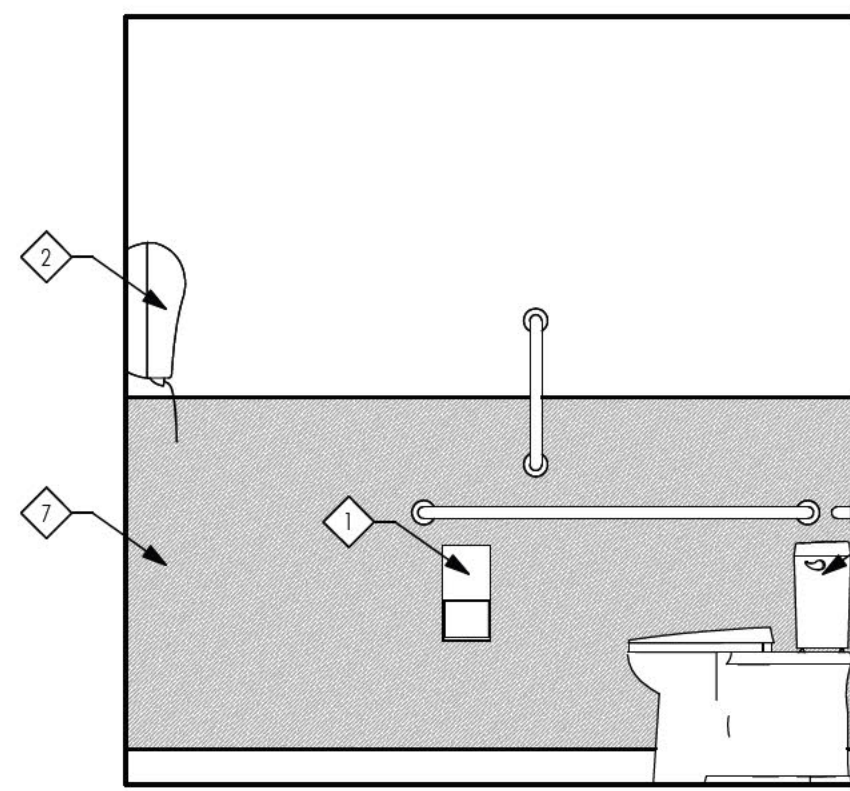
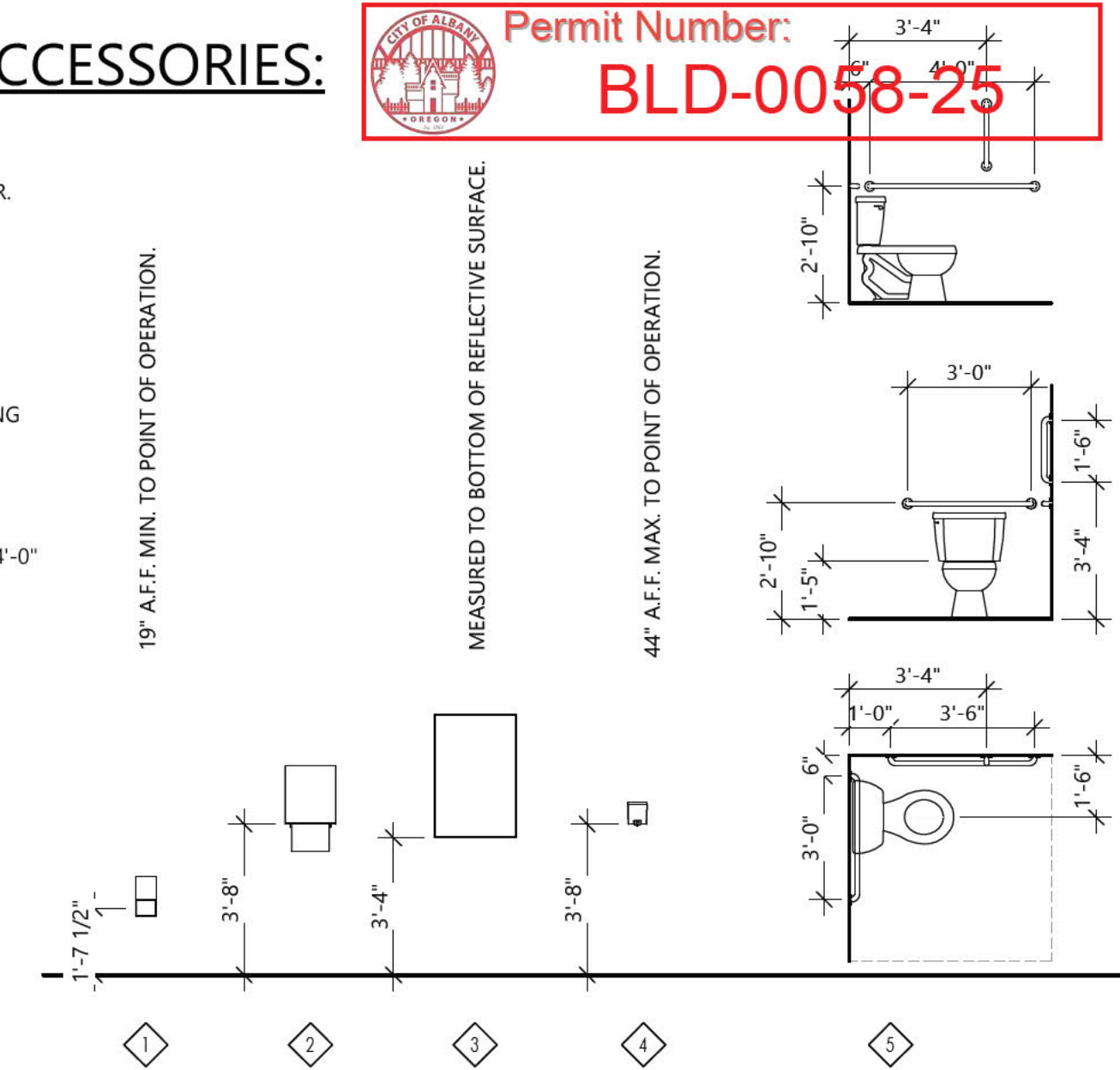

2 RESTROOM ELEVATIONS
SCALE: 1/4" = 1'-0"

LIFT
ARCHITECTURE
1130 Liberty St SE Suite 230 | Salem, OR 97302

REGISTERED ARCHITECT
MATTHEW D. JOHNSON
SALEM, OREGON 13288
STATE OF OREGON

ADDITION & REMODEL
BRIGGS BUILDING
333 W 1ST AVE ALBANY OR. 97321

REVISIONS:

SHEET:
A2.53
RESTROOM
ELEVATIONS

PROJECT # 2024-014
DATE: 3/4/2025

Permit Number:
BLD-0058-25

SECTION NOTES:

- 1 CONCRETE FOOTING PER STRUCTURAL.
- 2 FULLY-GROUTED CMU WALL.
- 3 WOOD-FRAMED EXTERIOR WALL. R-21 INSULATION BATTS EACH STUD BAY.
- 4 MINIMUM R-30 INSULATION AT CRAWLSPACE.
- 5 CONTINUOUS 10 MIL VAPOR BARRIER AT CRAWLSPACE.
- 6 PREFINISHED METAL PARAPET CAP.
- 7 60 MIL TPO MEMBRANE ROOF ASSEMBLY. MINIMUM R-30 RIGID INSULATION ENTIRELY ABOVE ROOF DECK.
- 8 2x4 FURRING WALL W/ R-15 INSULATION BATTS.
- 9 NEW 5/8" GYPSUM WALLBOARD CEILING ATTACHED TO UNDERSIDE OF EXISTING JOISTS.
- 10 EXISTING ROOF ASSEMBLY TO REMAIN.
- 11 FABRIC AWNING BY OTHERS.
- 12 R-49 INSULATION AT ENTRY ALCOVE CEILING.
- 13 EXTERIOR CONCRETE STAIR AND LANDING. PROVIDE MINIMUM 42" H GUARDRAIL AT OPEN SIDES.
- 14 WOOD WINDOW ASSEMBLY.
- 15 WOOD STOREFRONT ASSEMBLY.



ADDITION & REMODEL
BRIGGS BUILDING
333 W 1ST AVE ALBANY OR. 97321

REVISIONS:
1 4/10/2025 Rear Elevation

SHEET:
A3.01
BUILDING SECTIONS

PROJECT # 2024-014
DATE: 3/4/2025

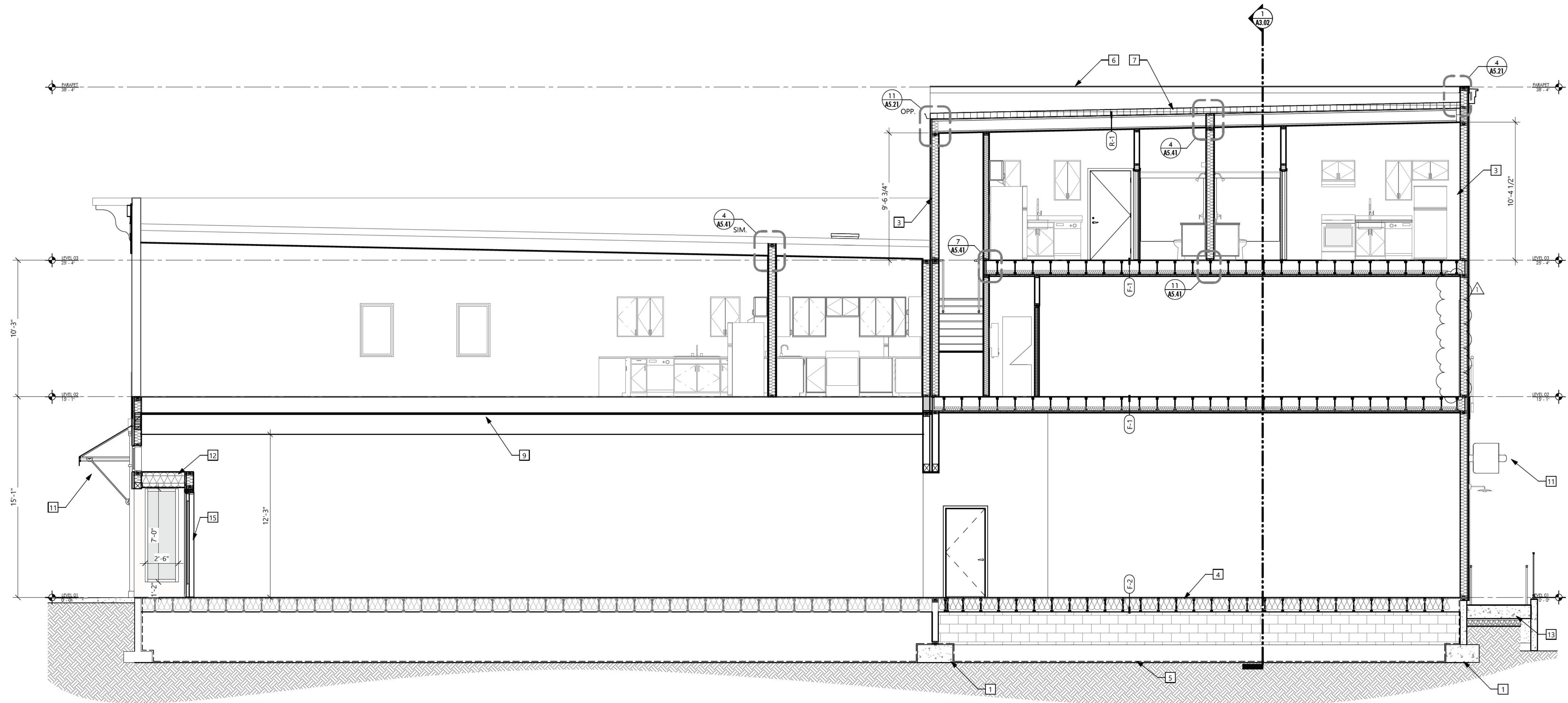

1 SECTION A
SCALE: 1/4" = 1'-0"

Copyright © 2025, LIFT Architecture



ADDITION & REMODEL
BRIGGS BUILDING
333 W 1ST AVE ALBANY OR. 97321

REVISIONS:
3 9/2/2025 Match Ex. Cond.

SHEET:
A3.02
BUILDING SECTIONS

PROJECT # 2024-014
DATE: 3/4/2025

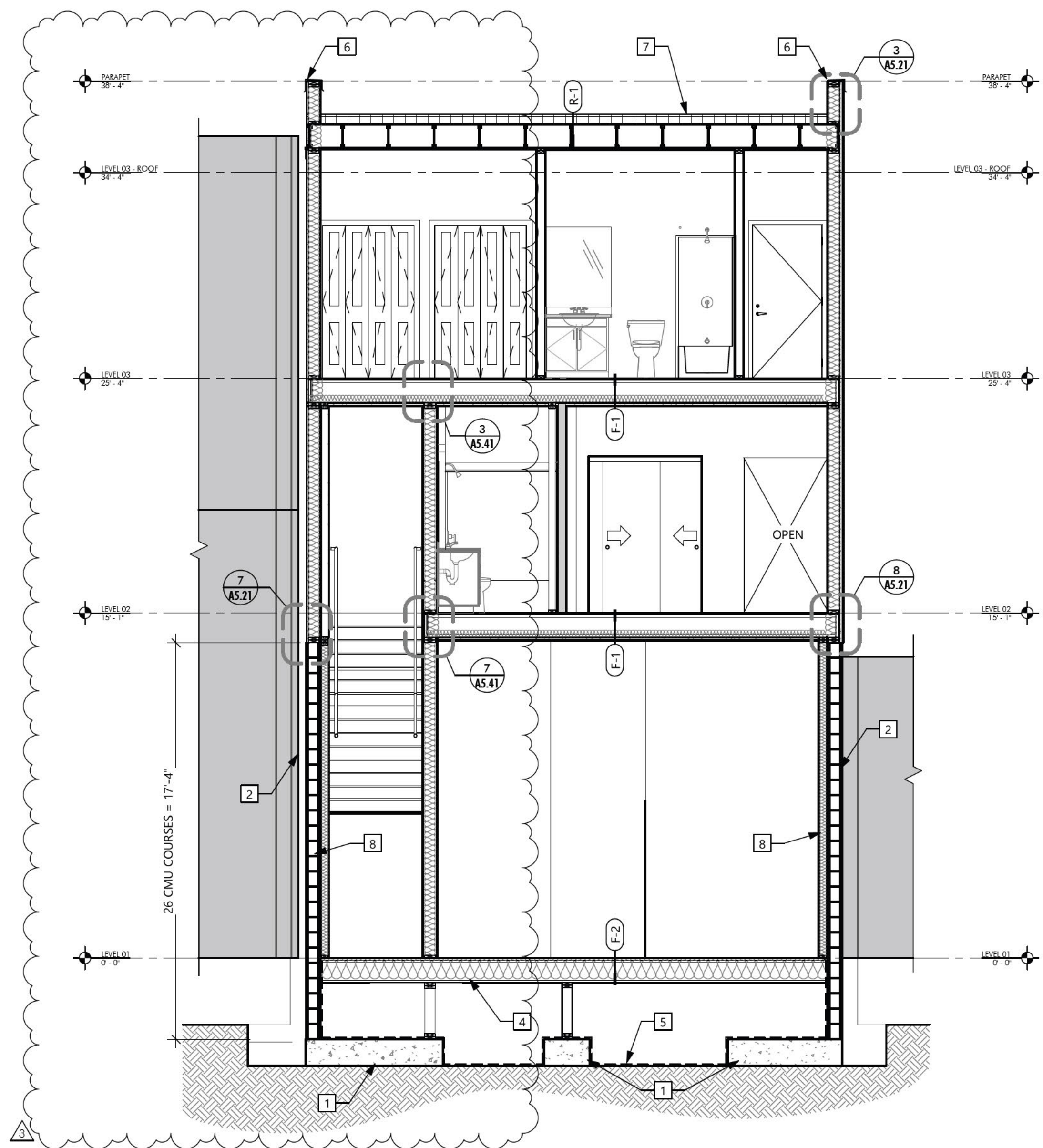

SECTION NOTES:

- 1 CONCRETE FOOTING PER STRUCTURAL.
- 2 FULLY-GROUTED CMU WALL.
- 3 WOOD-FRAMED EXTERIOR WALL. R-21 INSULATION BATTES EACH STUD BAY.
- 4 MINIMUM R-30 INSULATION AT CRAWLSPACE.
- 5 CONTINUOUS 10 MIL VAPOR BARRIER AT CRAWLSPACE.
- 6 PREFINISHED METAL PARAPET CAP.
- 7 60 MIL TPO MEMBRANE ROOF ASSEMBLY. MINIMUM R-30 RIGID INSULATION ENTIRELY ABOVE ROOF DECK.
- 8 2x4 FURRING WALL W/ R-15 INSULATION BATTES.
- 9 NEW 5/8" GYPSUM WALLBOARD CEILING ATTACHED TO UNDERSIDE OF EXISTING JOISTS.
- 10 EXISTING ROOF ASSEMBLY TO REMAIN.
- 11 FABRIC AWNING BY OTHERS.
- 12 R-49 INSULATION AT ENTRY ALCOVE CEILING.
- 13 EXTERIOR CONCRETE STAIR AND LANDING. PROVIDE MINIMUM 42" H GUARDRAIL AT OPEN SIDES.
- 14 WOOD WINDOW ASSEMBLY.
- 15 WOOD STOREFRONT ASSEMBLY.

1 SECTION B
SCALE: 1/4" = 1'-0"

Copyright © 2025, LIFT Architecture

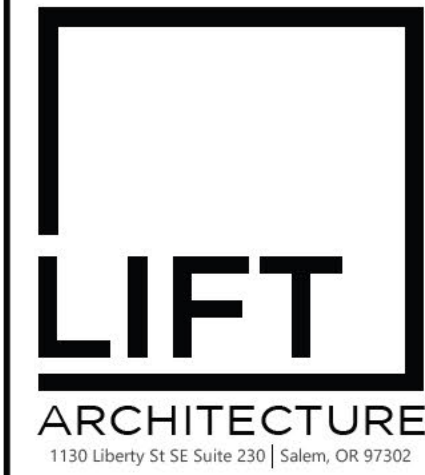

ADDITION & REMODEL
BRIGGS BUILDING
333 W 1ST AVE ALBANY OR. 97321

REVISIONS:

2	5/2/2025	Plan Review
---	----------	-------------

SHEET:
A4.11
DETAIL STAIR PLANS

PROJECT # 2024-014
DATE: 3/4/2025

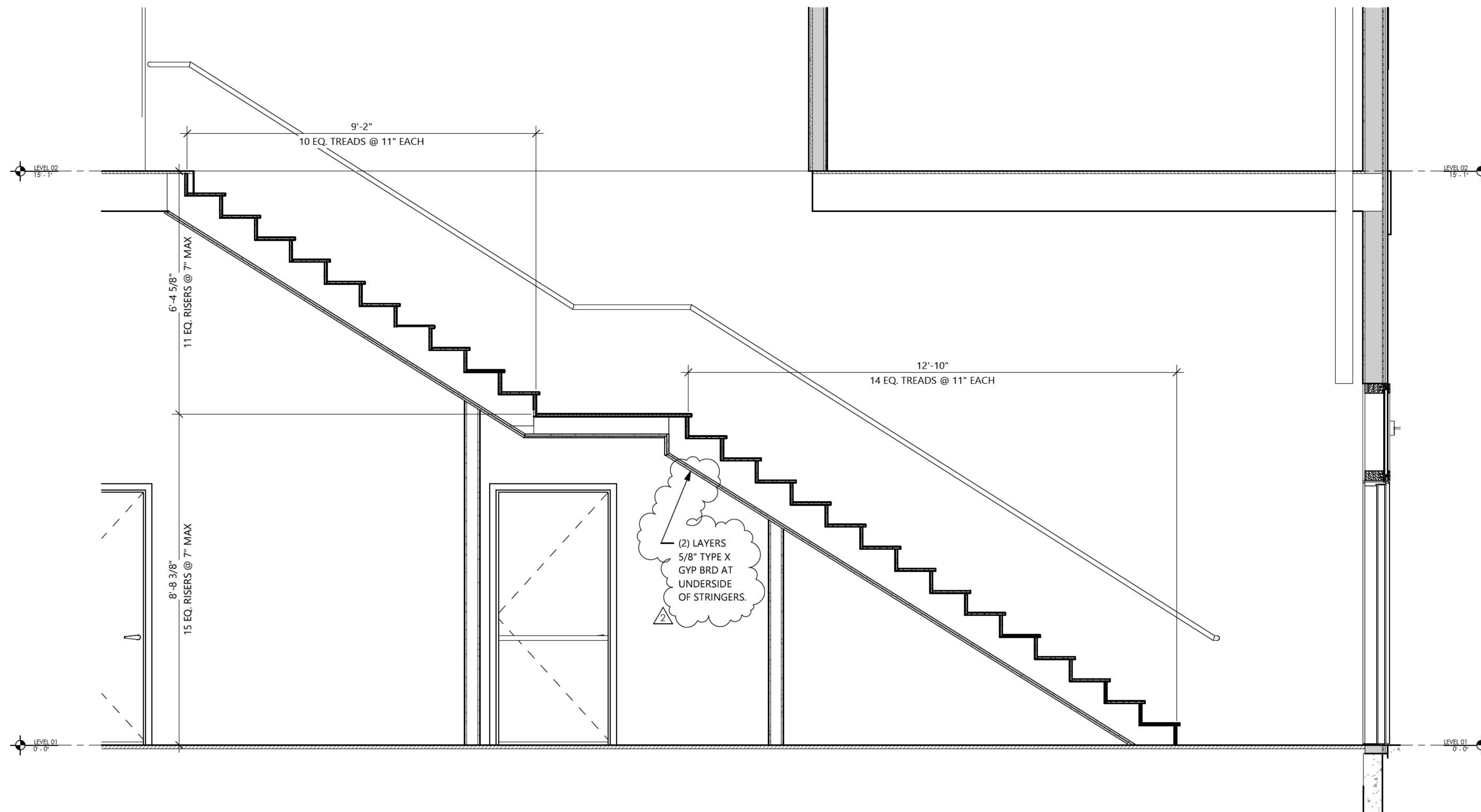

1 NORTH STAIR SECTION
SCALE: 1/2" = 1'-0"

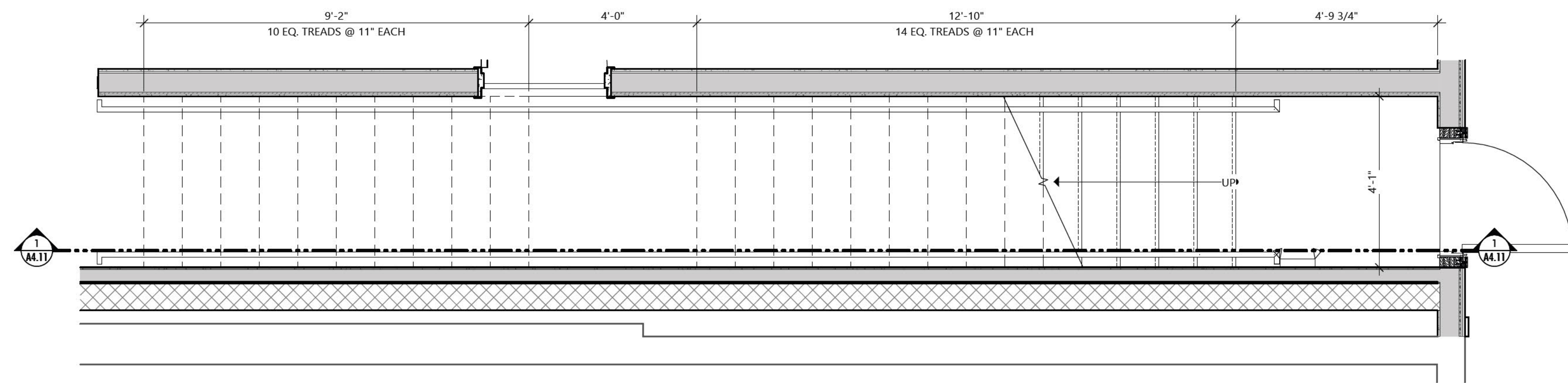

3 LEVEL 01 - NORTH STAIR
SCALE: 1/2" = 1'-0"

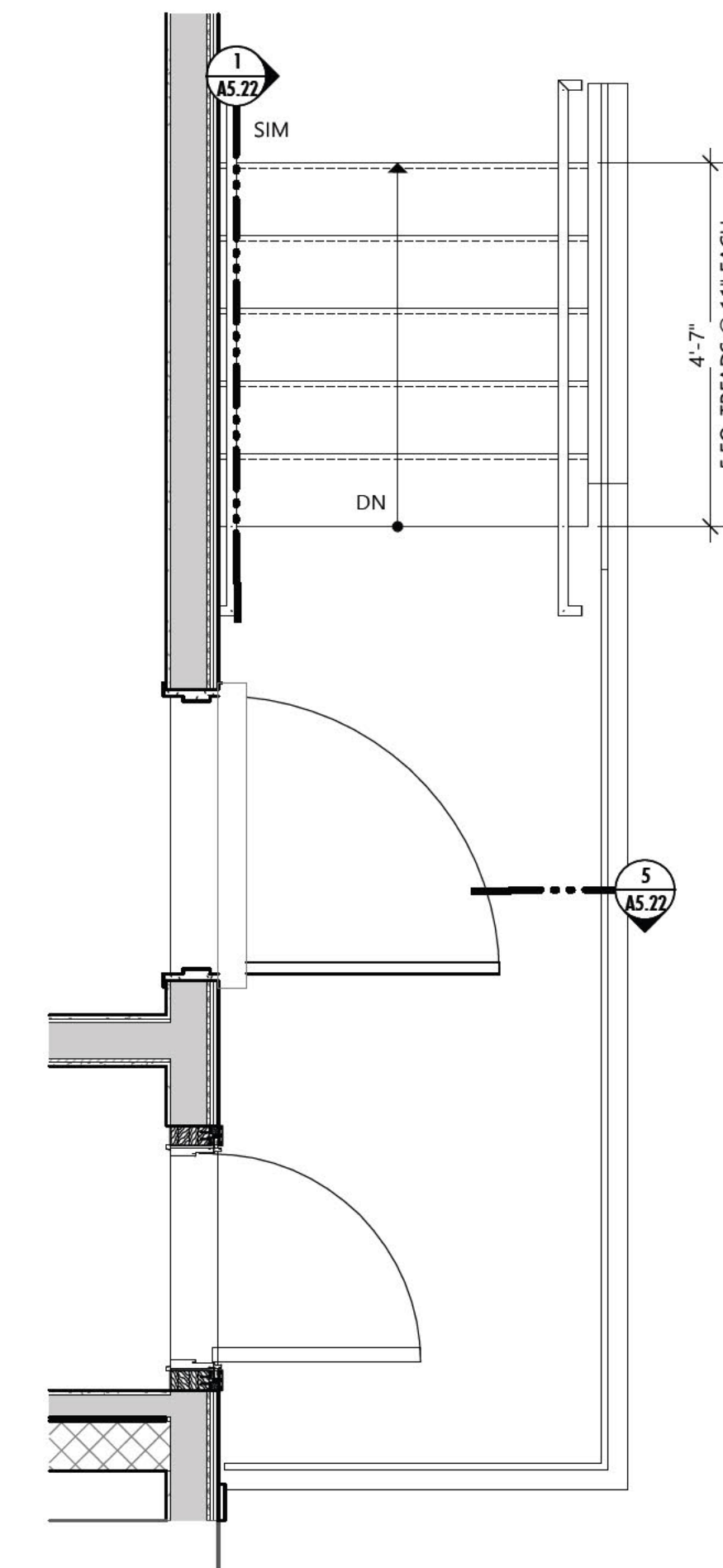

4 LEVEL 01 - EXTERIOR STAIR PLAN
SCALE: 1/2" = 1'-0"



ADDITION & REMODEL
BRIGGS BUILDING
333 W 1ST AVE ALBANY OR. 97321

REVISIONS:
2 5/2/2025 Plan Review

SHEET:
A4.12
DETAIL STAIR PLANS

PROJECT # 2024-014
DATE: 3/4/2025

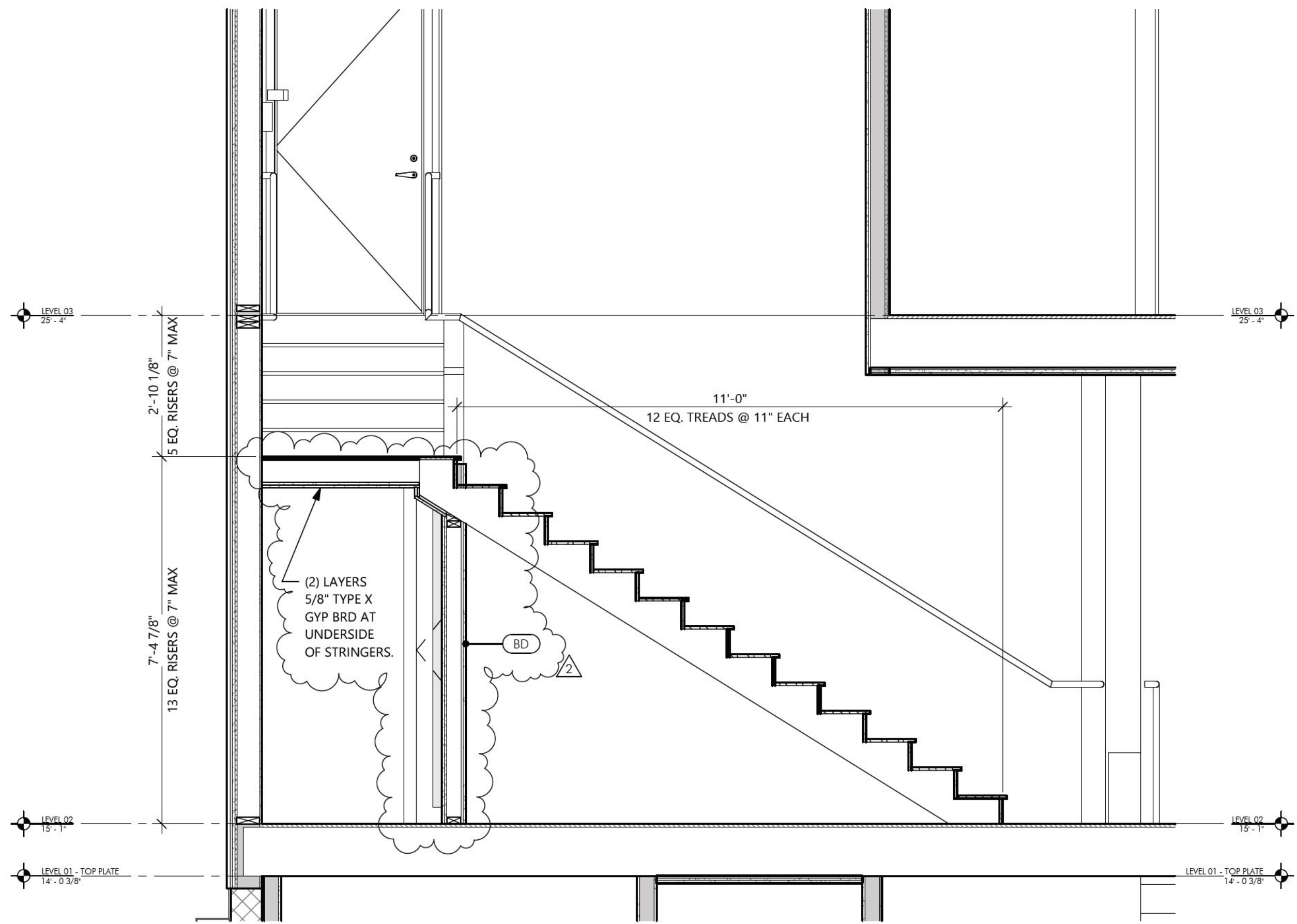

1 LEVEL 02 STAIR SECTION
SCALE: 1/2" = 1'-0"

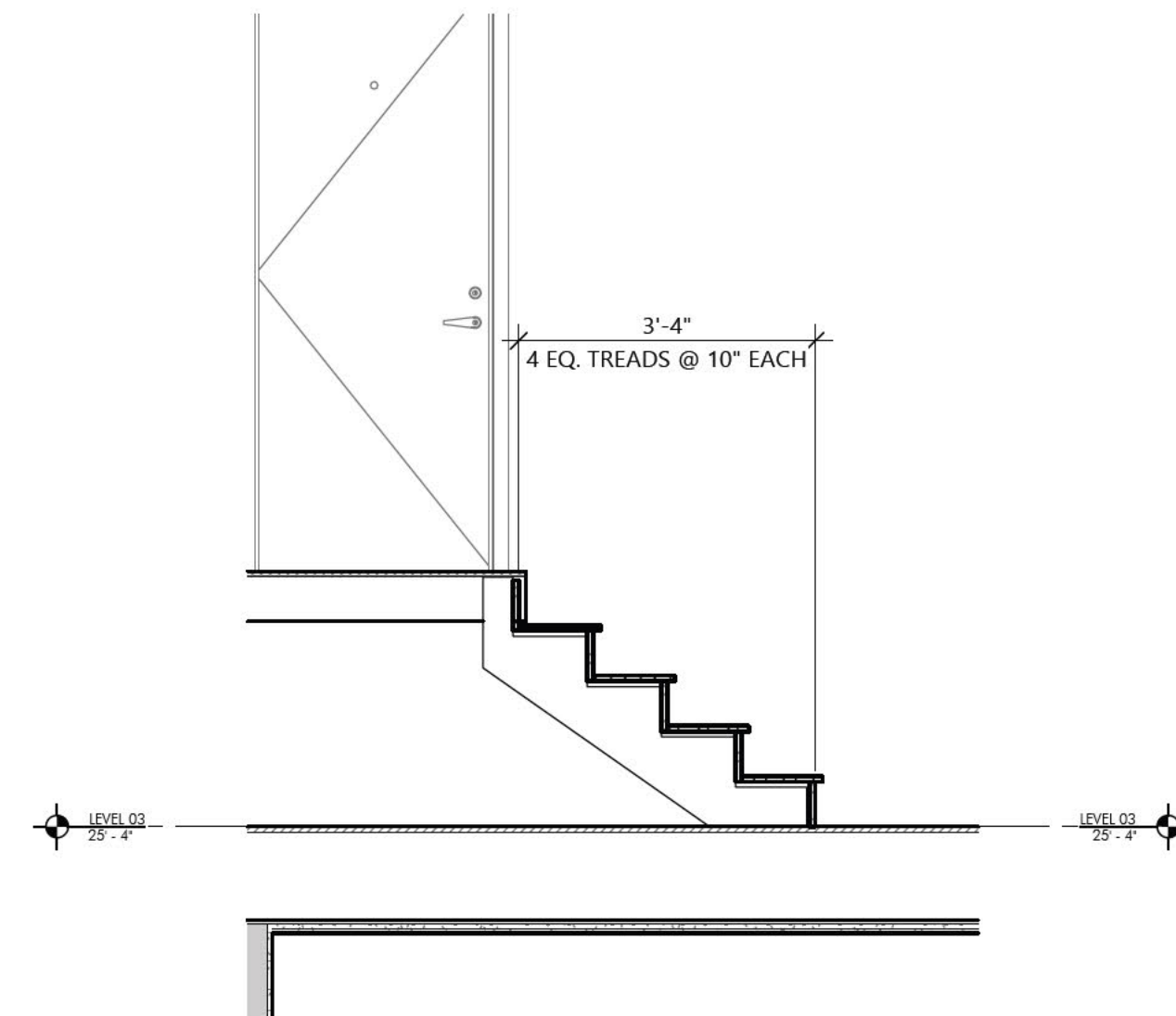

2 ROOF ACCESS STAIR SECTION
SCALE: 1/2" = 1'-0"

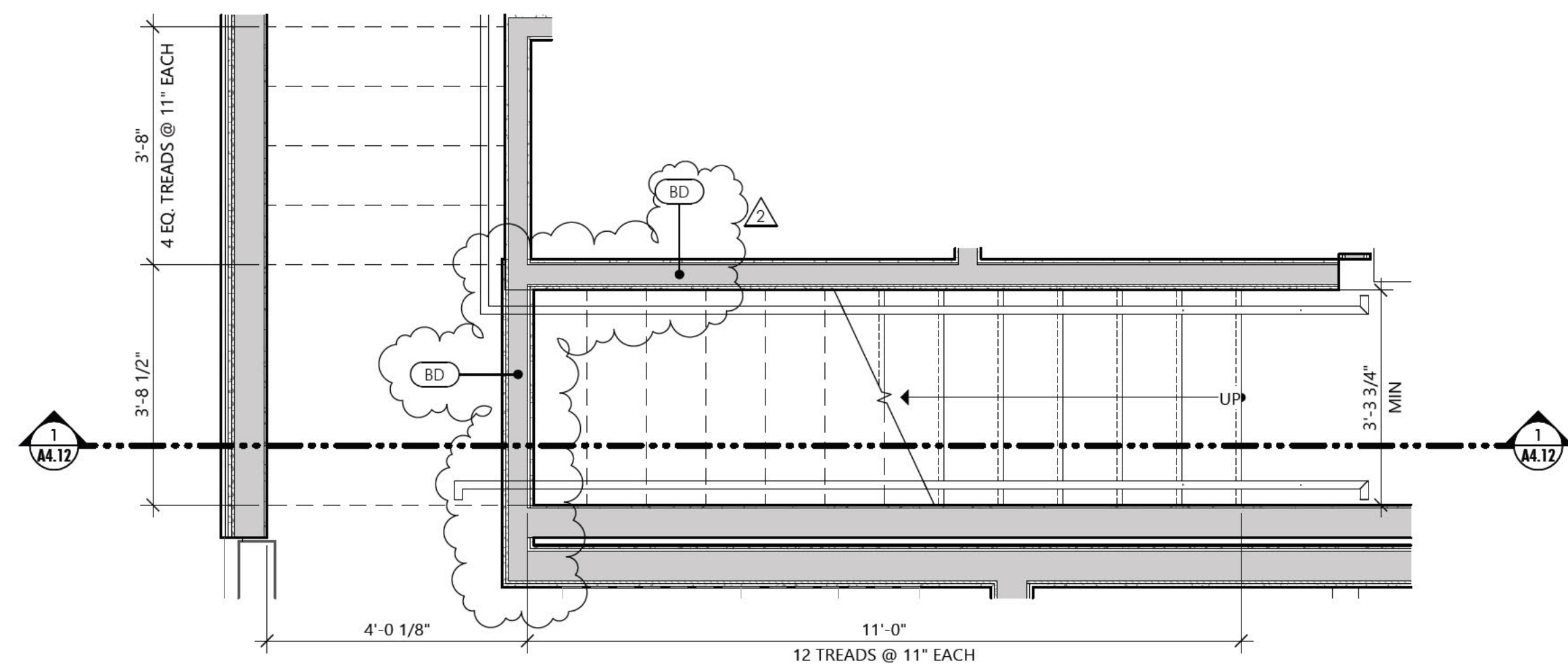

3 LEVEL 02 - STAIR
SCALE: 1/2" = 1'-0"

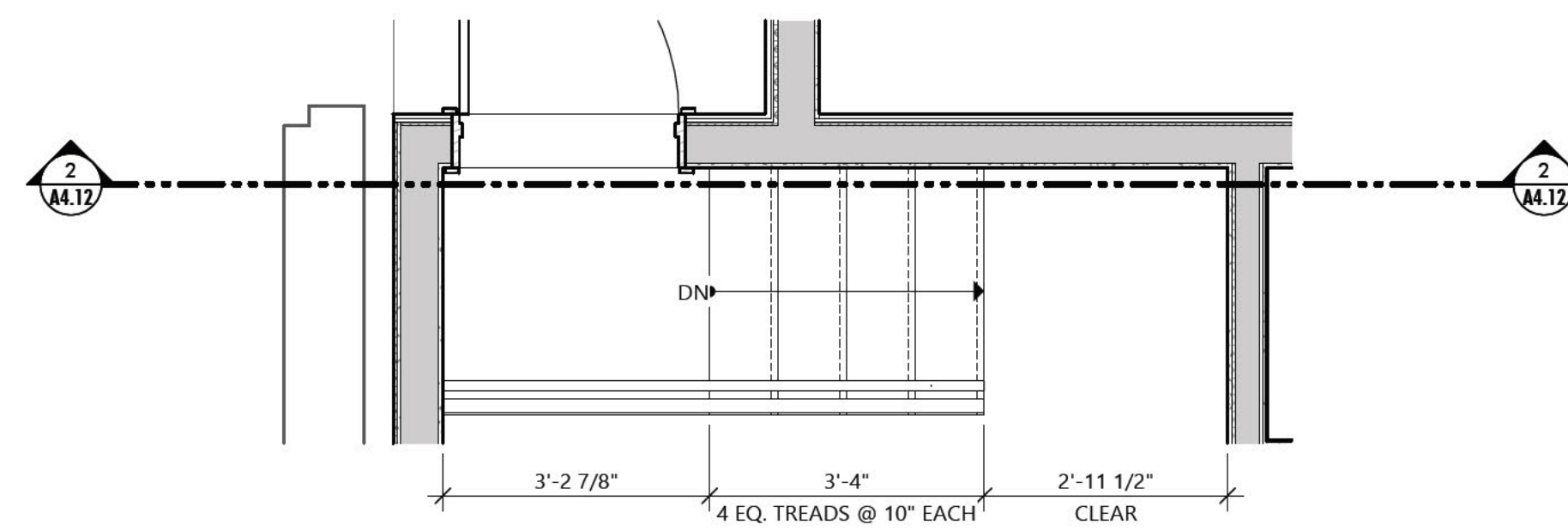

4 LEVEL 03 - ROOF ACCESS STAIR
SCALE: 1/2" = 1'-0"

Revised Page
01/30/2026

Permit Number
BLD 0058-25

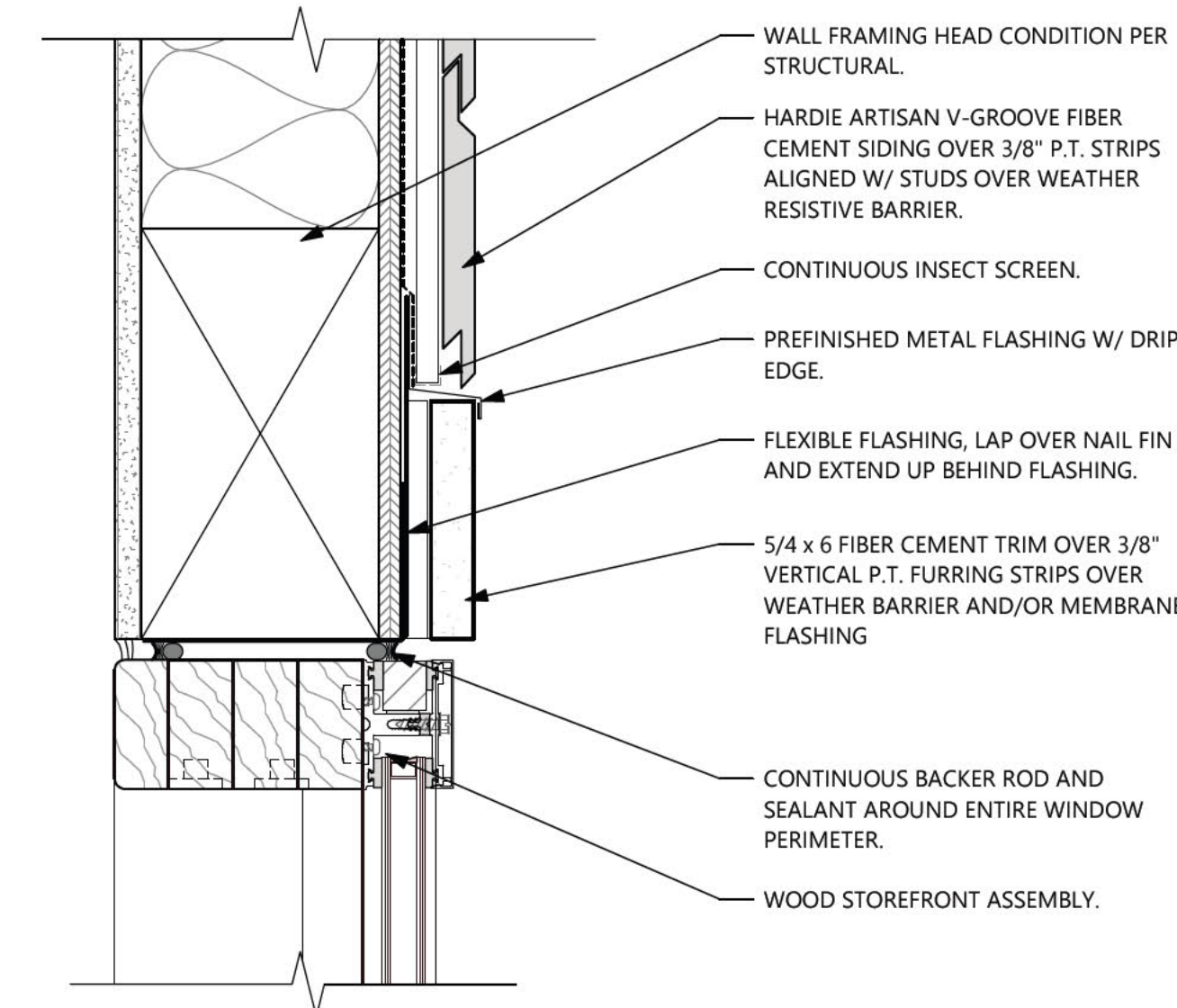

1 WOOD STOREFRONT HEAD AT FIBER CEMENT
SCALE: 3" = 1'-0"

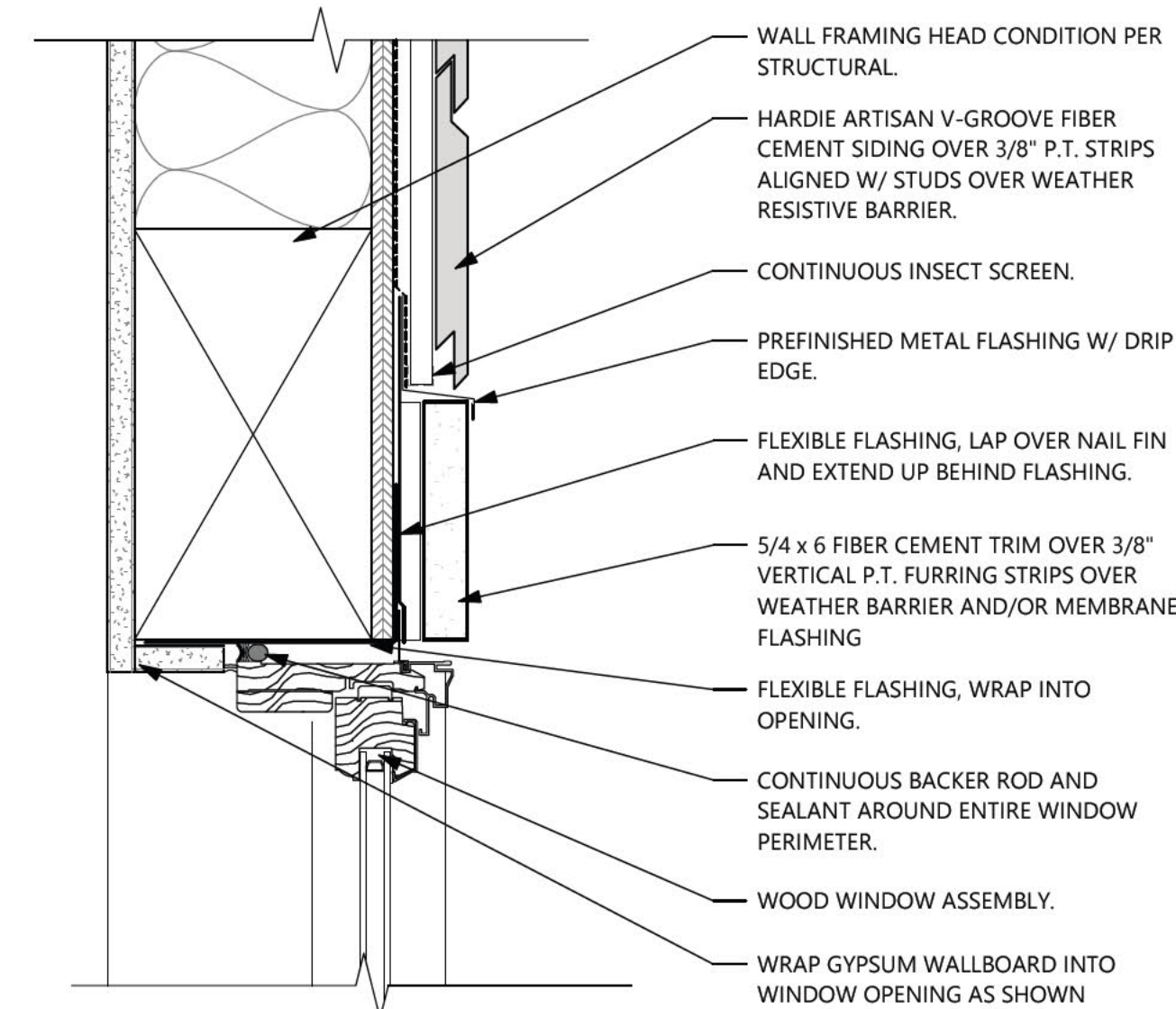

2 WOOD WINDOW HEAD AT FIBER CEMENT
SCALE: 3" = 1'-0"

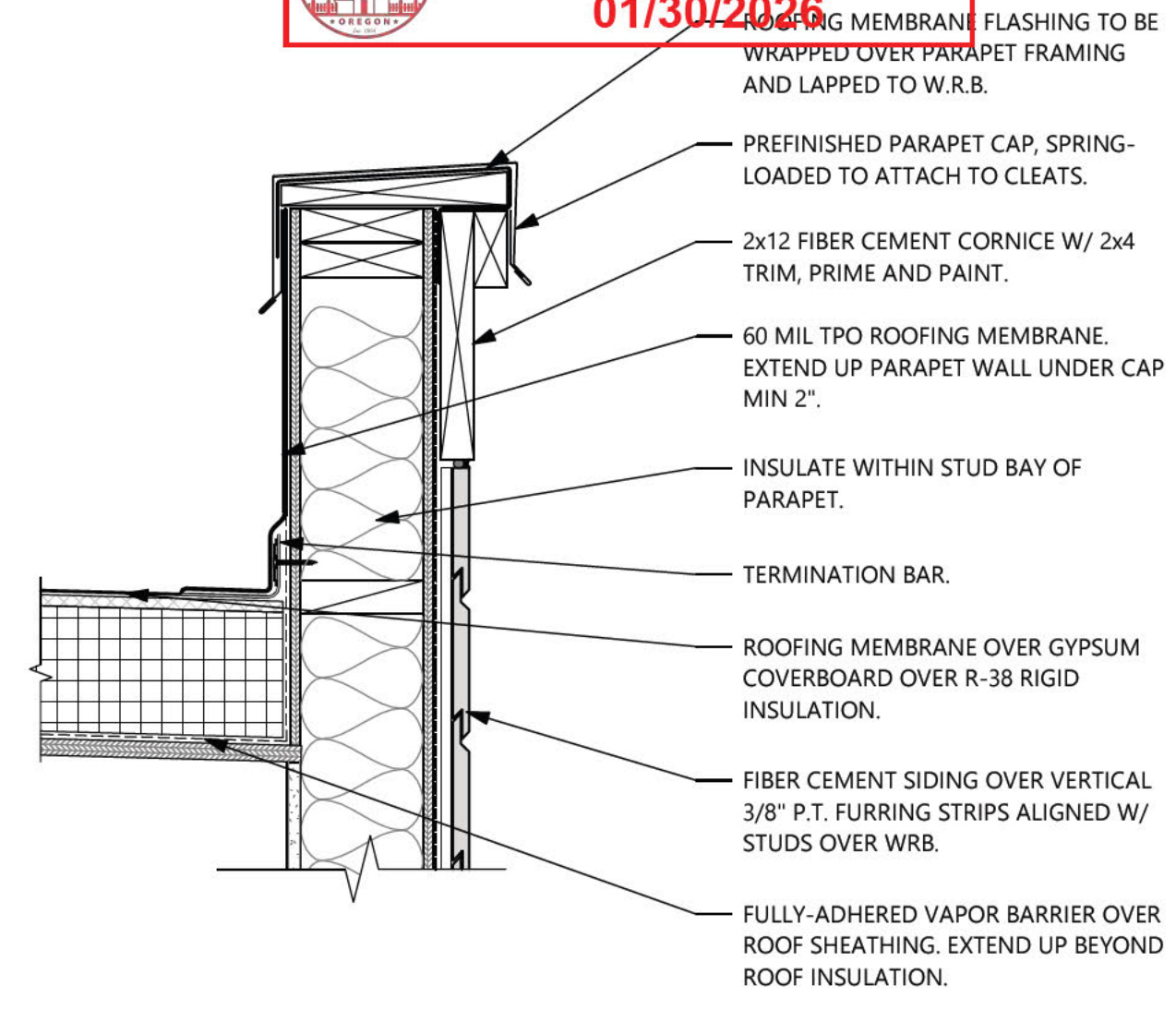

3 TYPICAL PARAPET
SCALE: 1 1/2" = 1'-0"

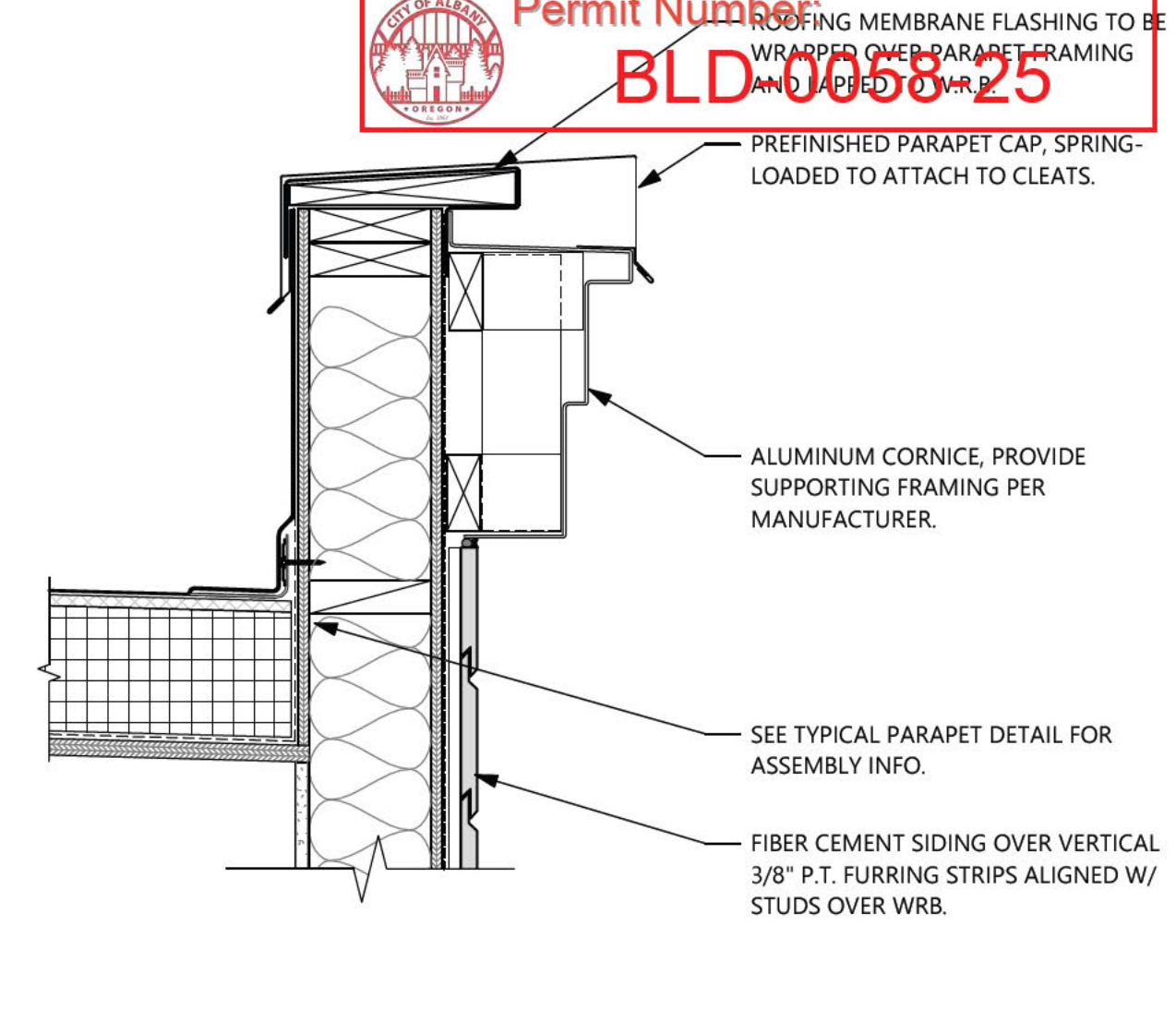

4 PARAPET W/ ALUMINUM CORNICE
SCALE: 1 1/2" = 1'-0"

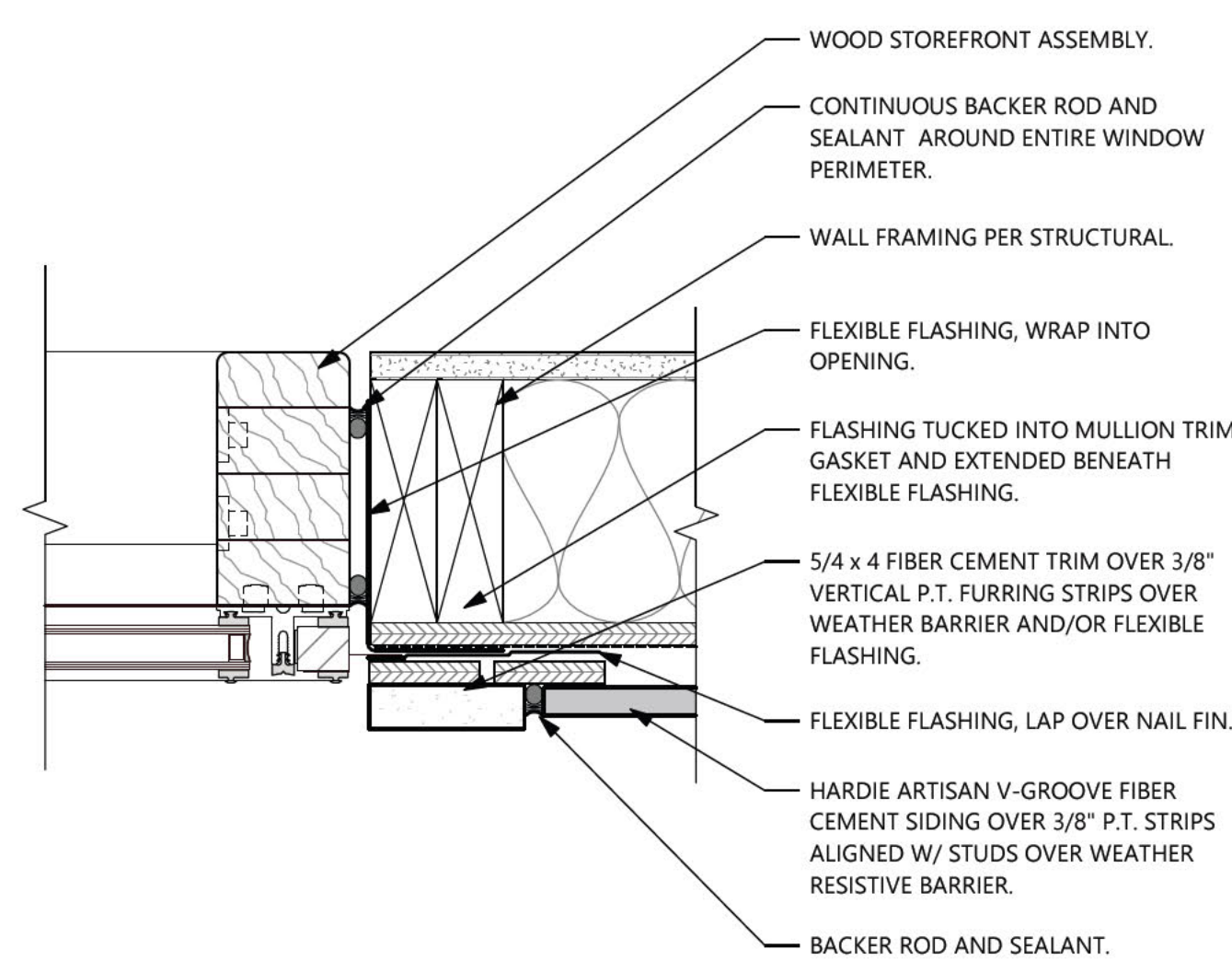

5 WOOD STOREFRONT JAMB AT FIBER CEMENT
SCALE: 3" = 1'-0"

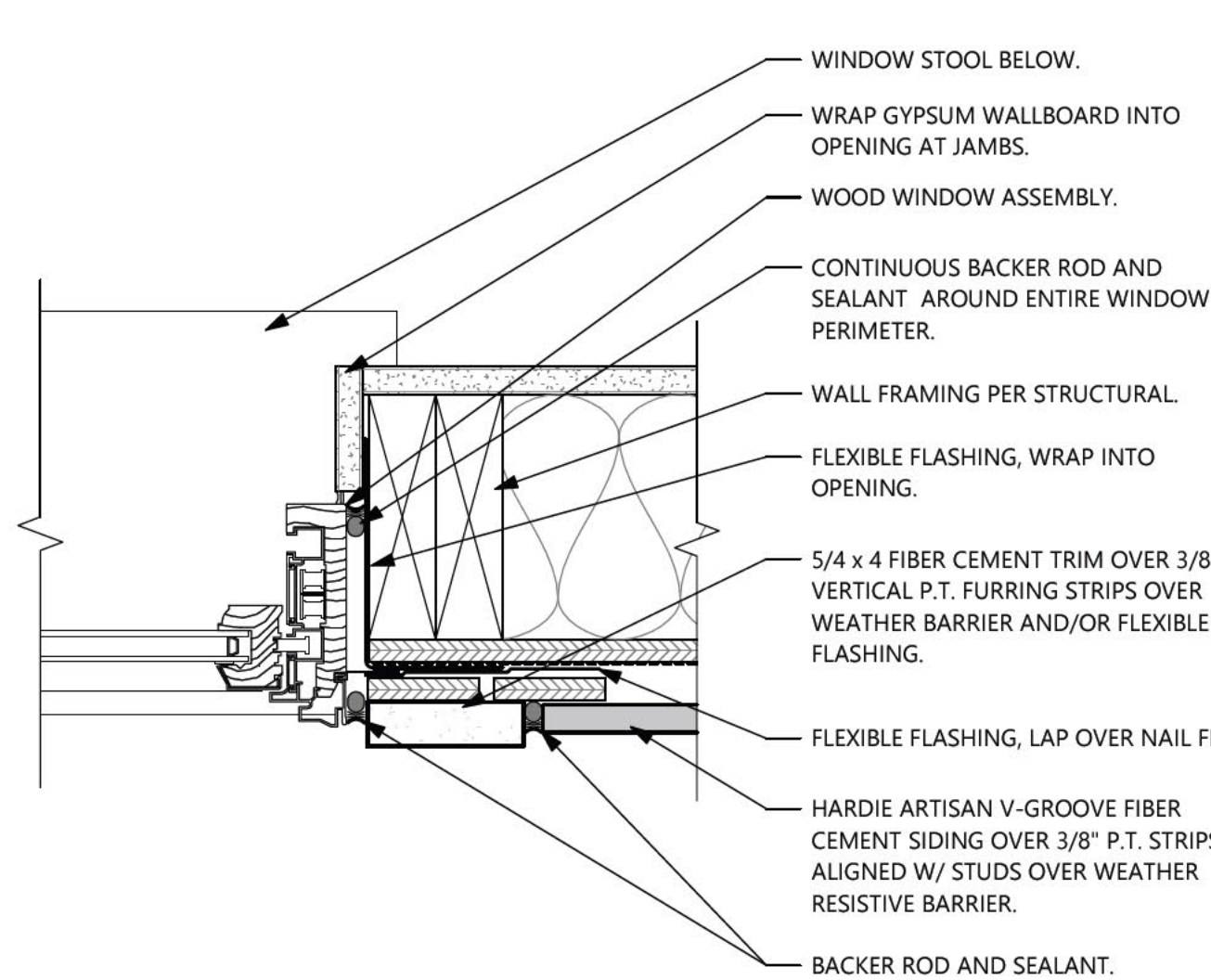

6 WOOD WINDOW JAMB AT FIBER CEMENT
SCALE: 3" = 1'-0"

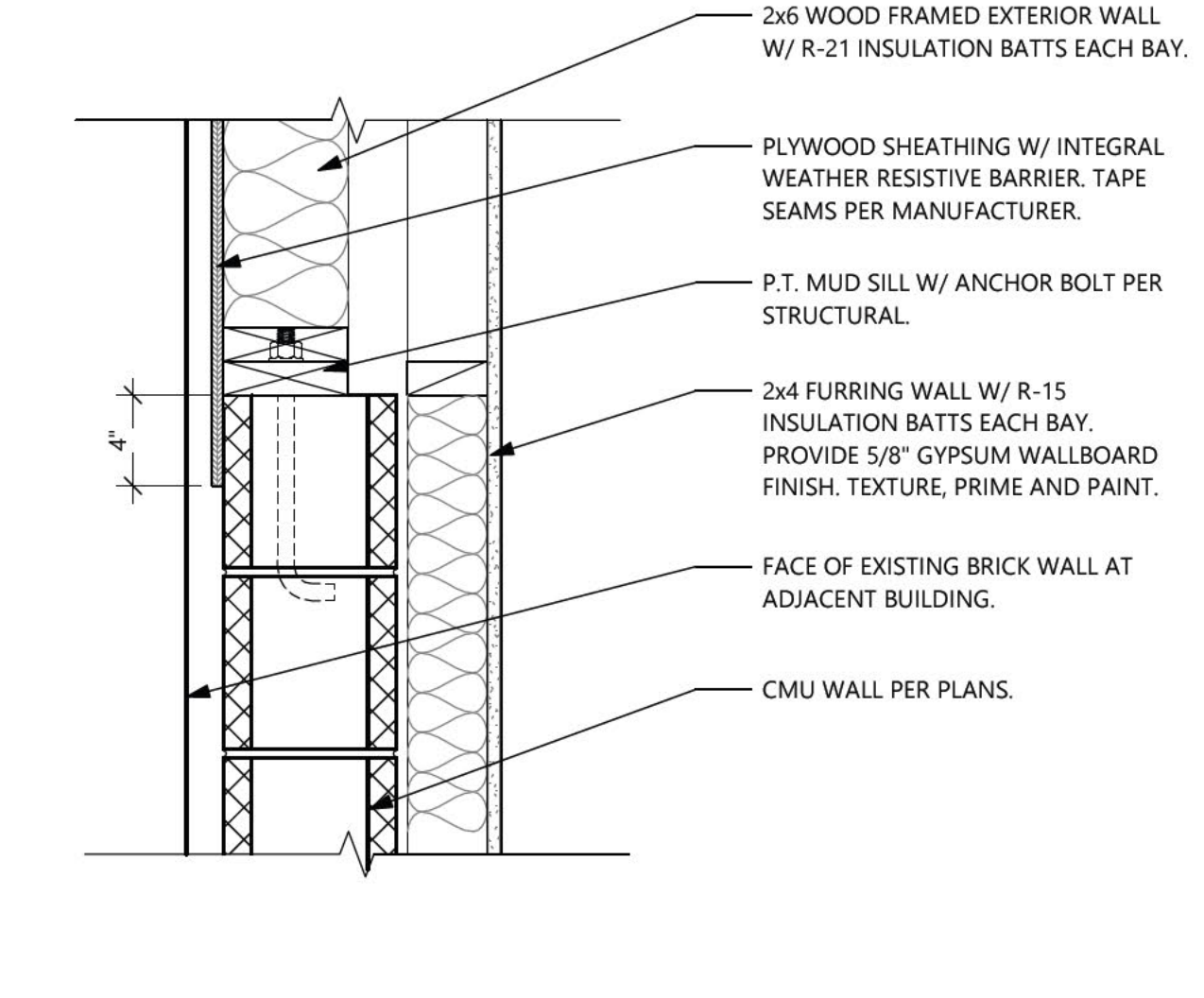

7 CMU/FRAMED WALL AT EXISTING WALL
SCALE: 1 1/2" = 1'-0"

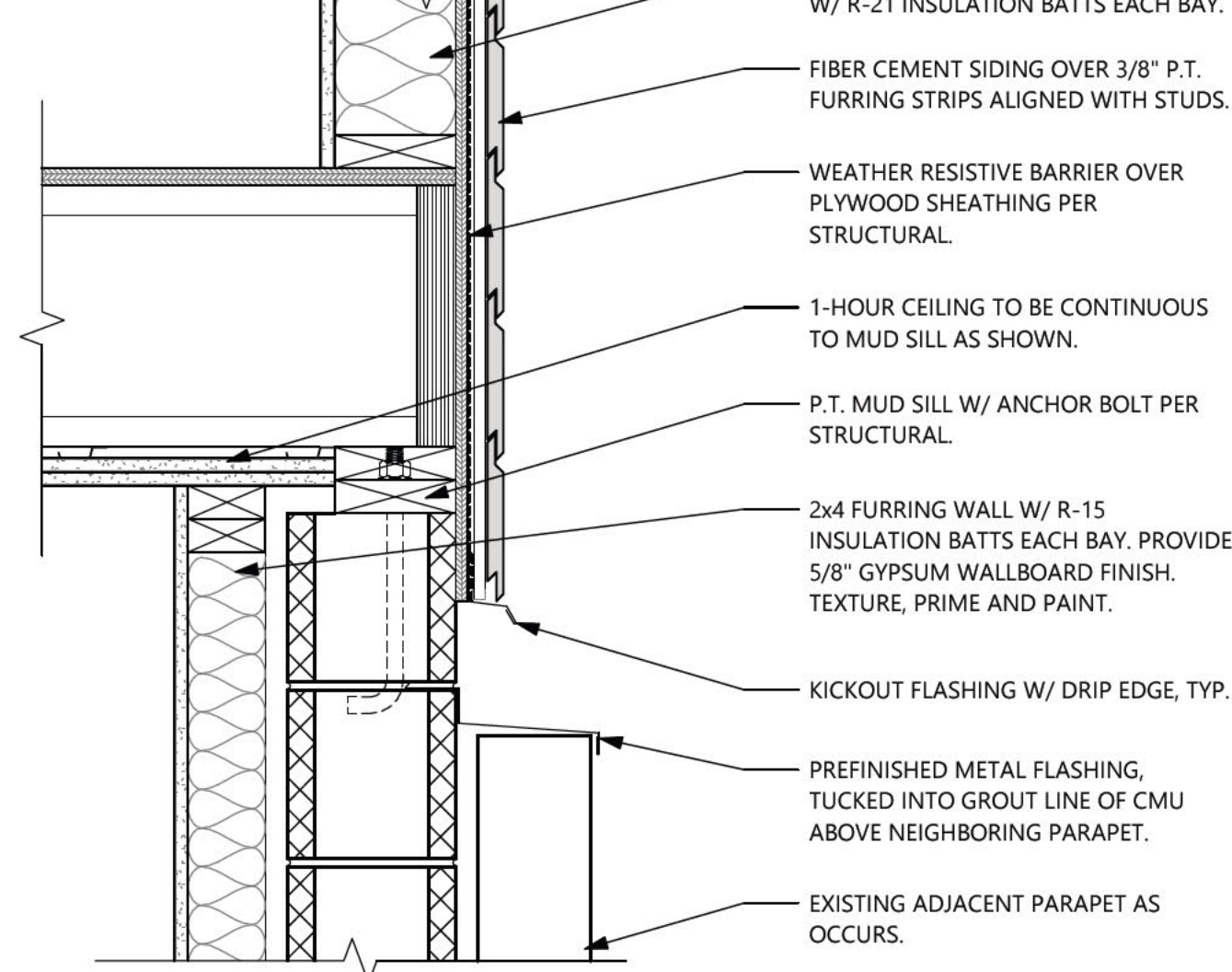

8 CMU/FRAMED WALL AT ADJACENT PARAPET
SCALE: 1 1/2" = 1'-0"

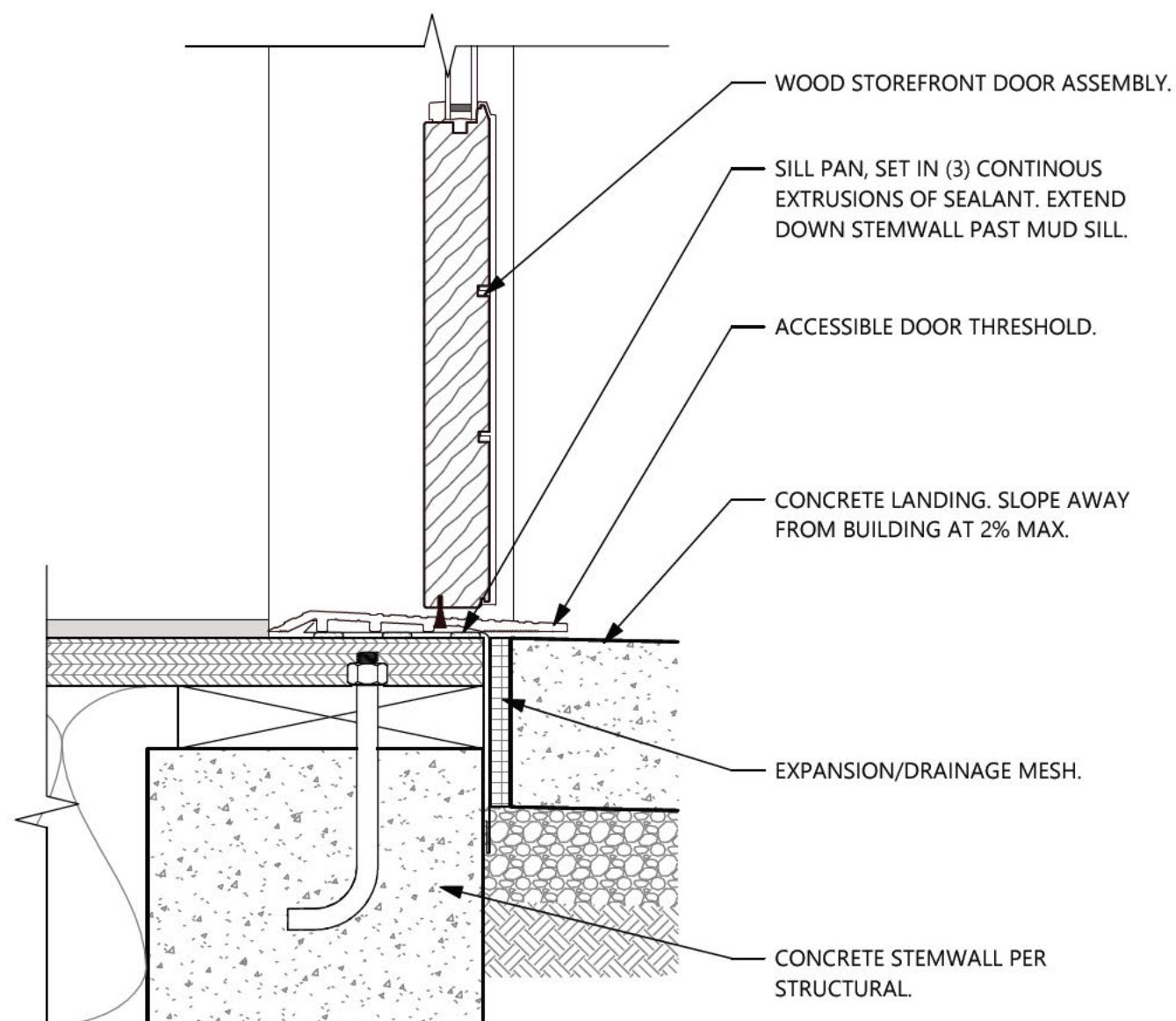

9 WOOD STOREFRONT DOOR THRESHOLD
SCALE: 3" = 1'-0"

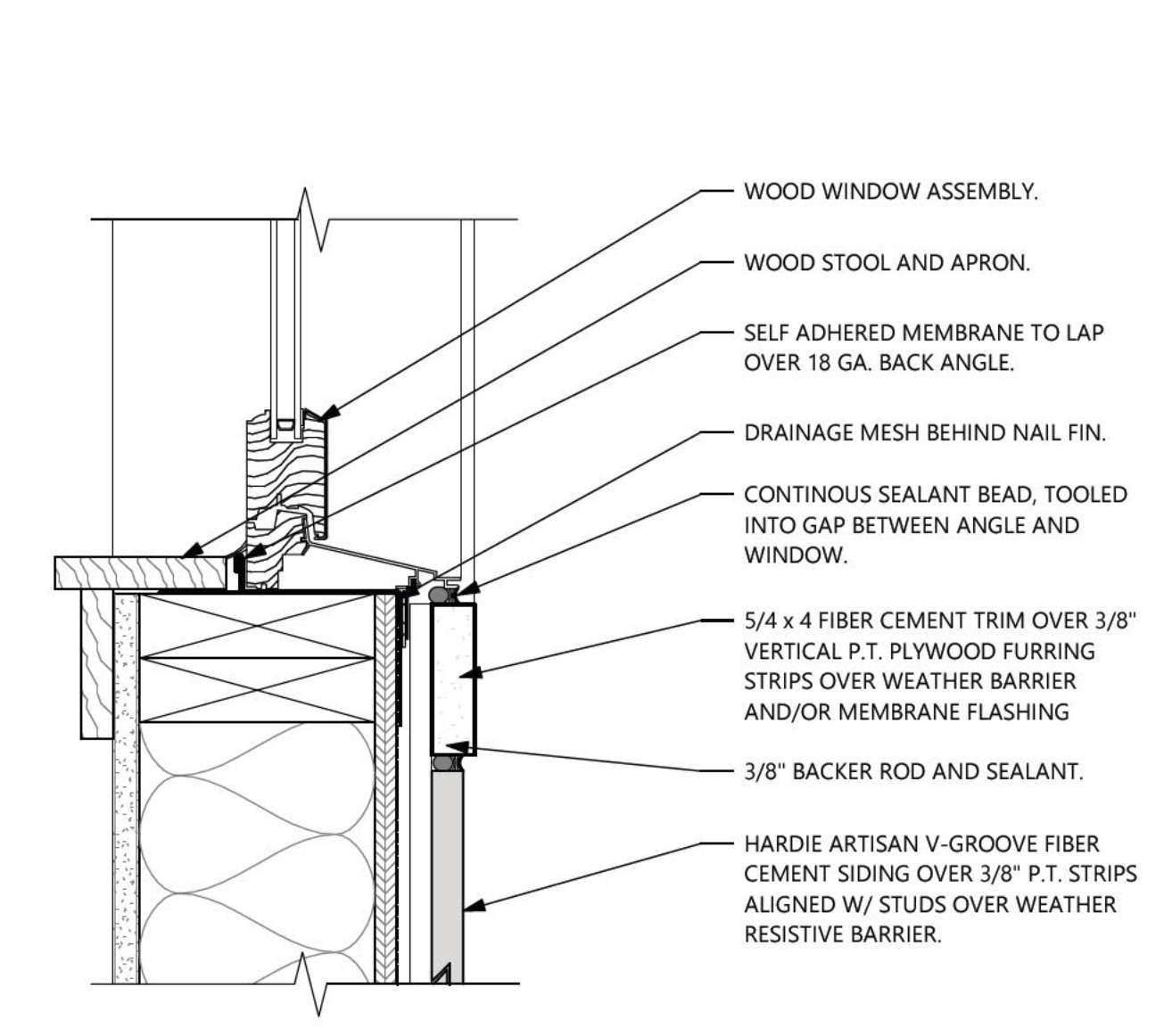

10 WOOD WINDOW SILL AT FIBER CEMENT
SCALE: 3" = 1'-0"

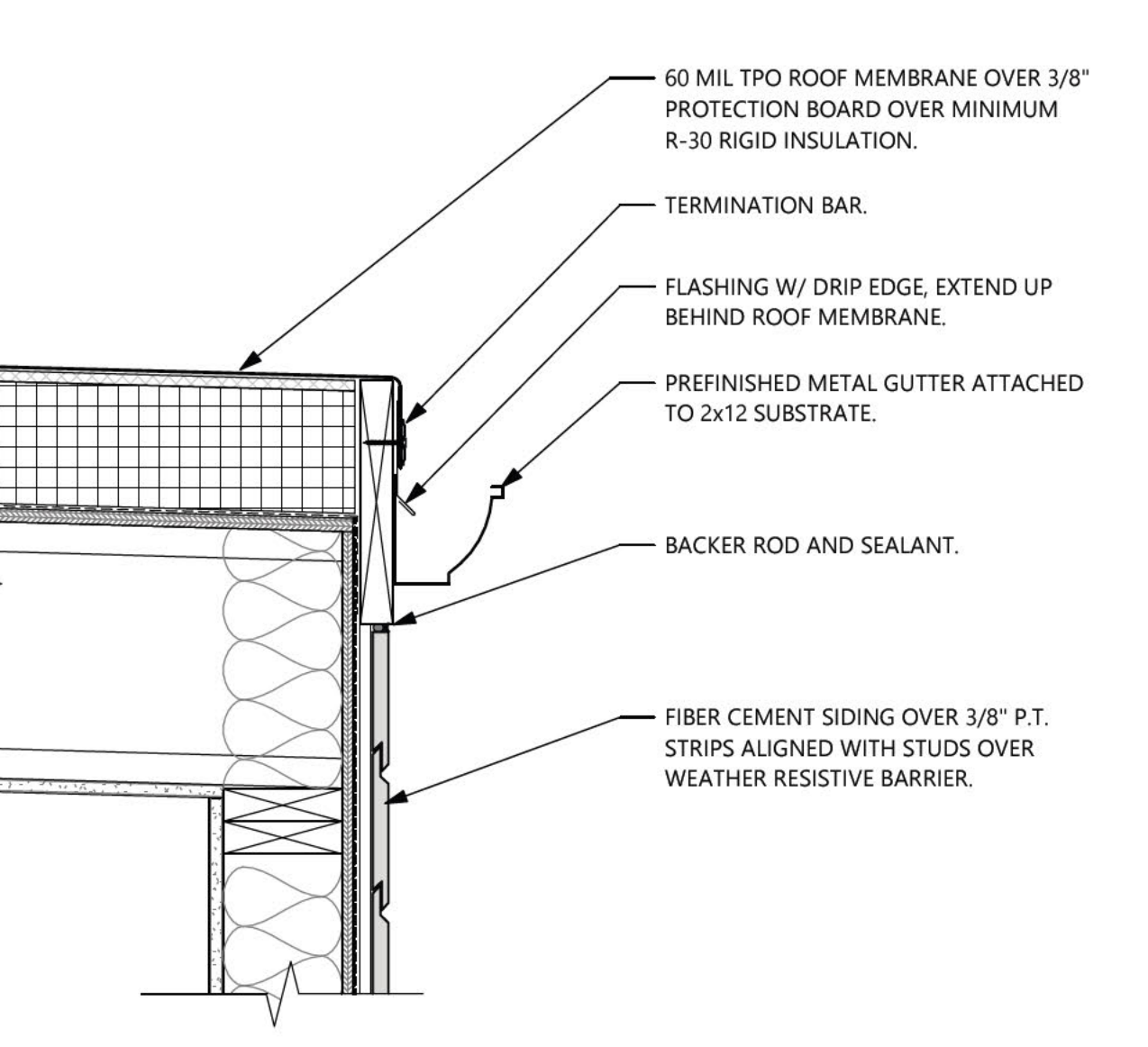

11 GUTTER AT ROOF EDGE
SCALE: 1 1/2" = 1'-0"

LIFT
ARCHITECTURE
1130 Liberty St Suite 230 | Salem, OR 97302

REGISTERED ARCHITECT
MATTHEW D. JOHNSON
SALEM, OREGON
13288
STATE OF OREGON

ADDITION & REMODEL
BRIGGS BUILDING
333 W 1ST AVE ALBANY OR. 97321

REVISIONS:

SHEET:
A5.21
EXTERIOR DETAILS

PROJECT # 2024-014
DATE: 3/4/2025

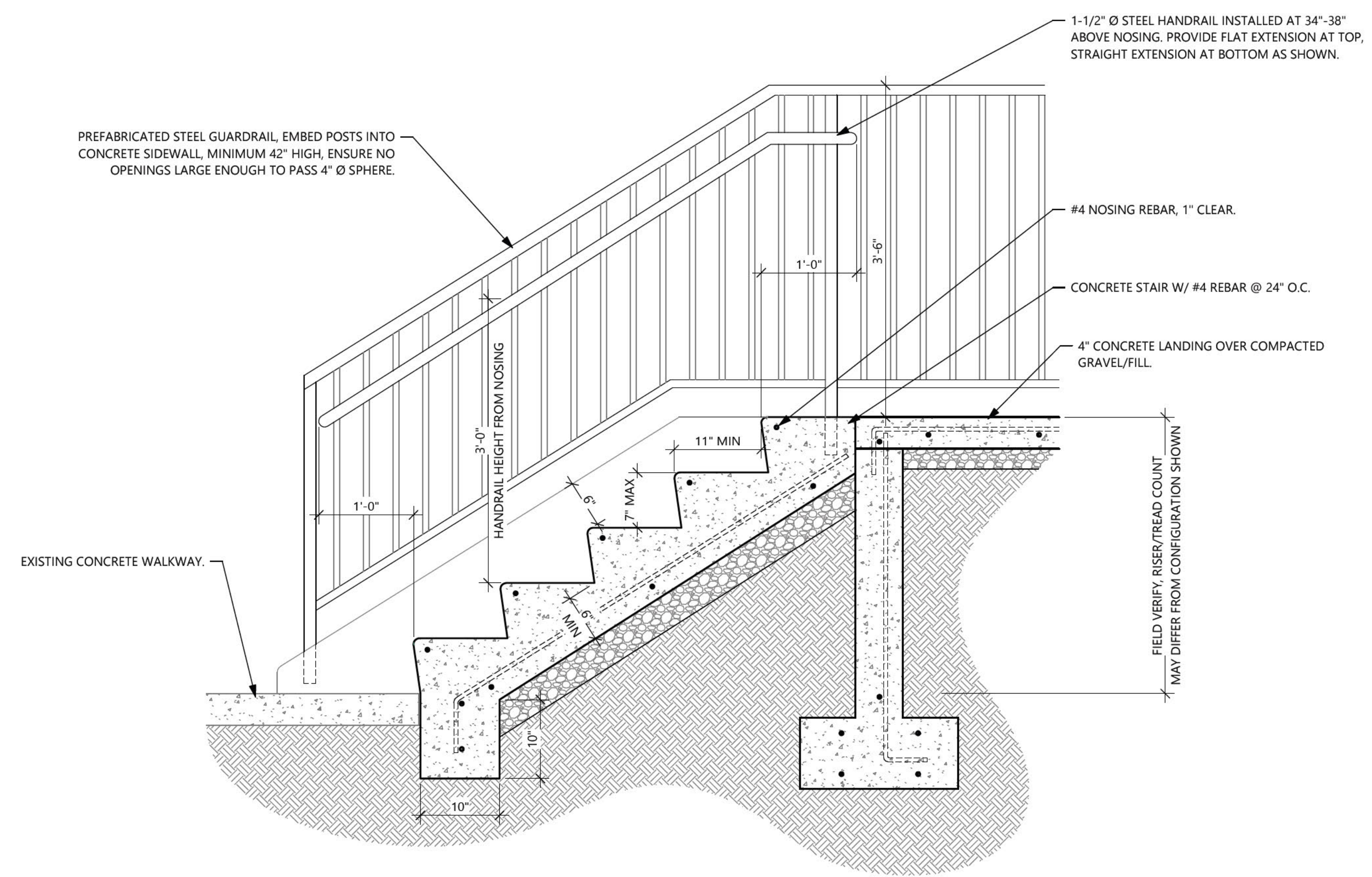

1 CONCRETE STAIR SECTION
SCALE: 1" = 1'-0"

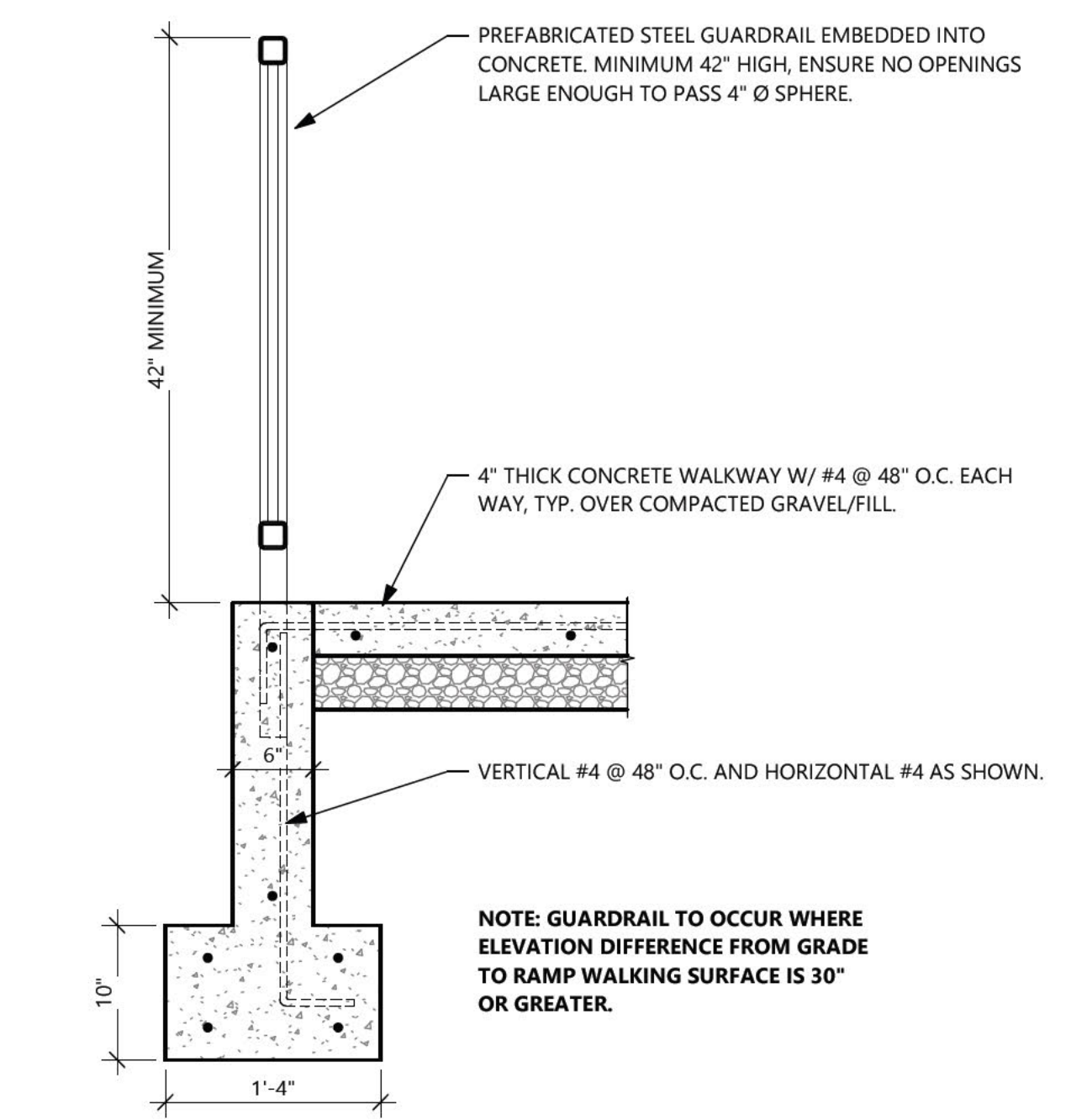

5 STAIR/LANDING GUARDRAIL SECTION
SCALE: 1" = 1'-0"

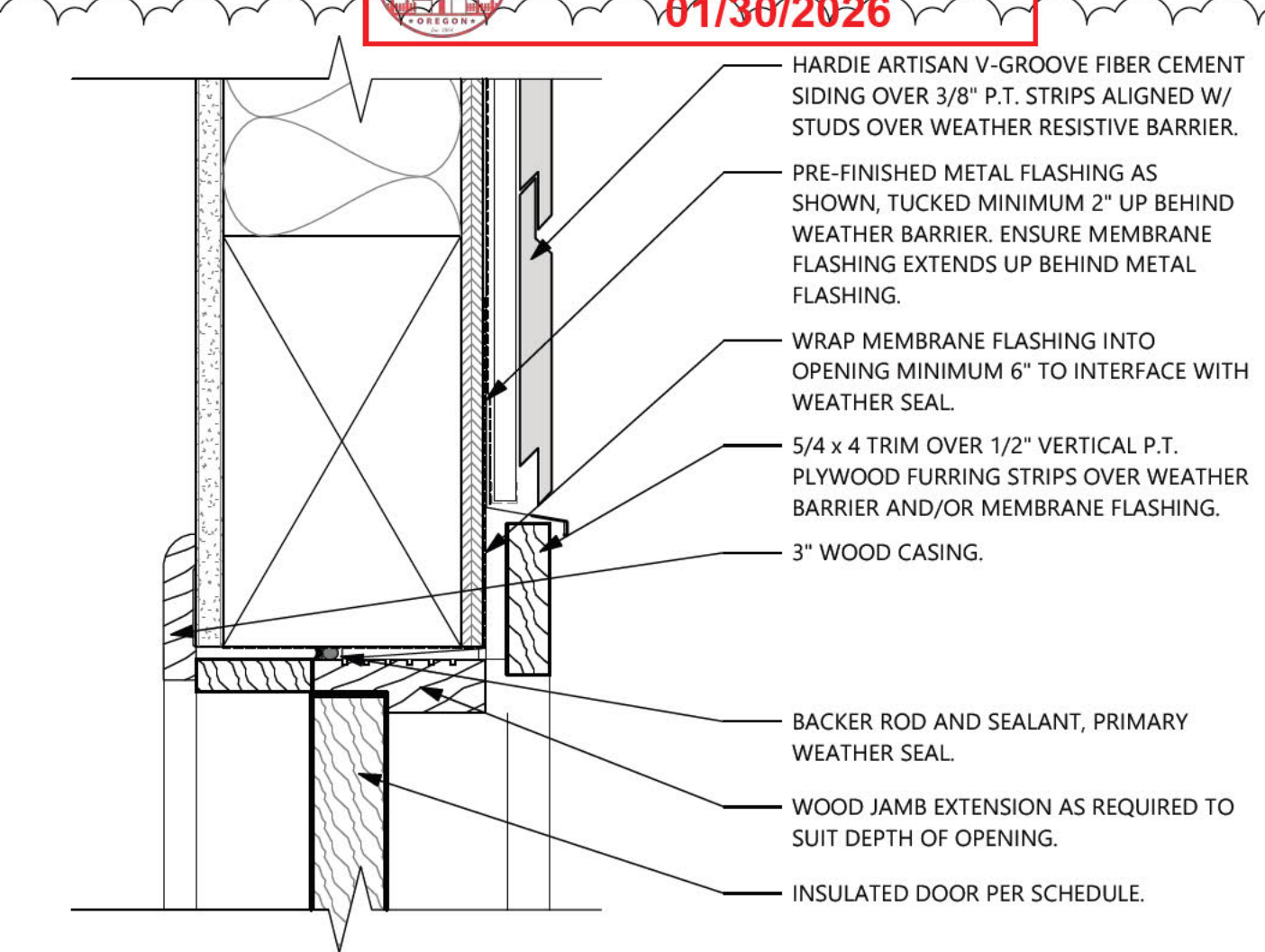

2 EXTERIOR WOOD DOOR HEAD
SCALE: 3" = 1'-0"

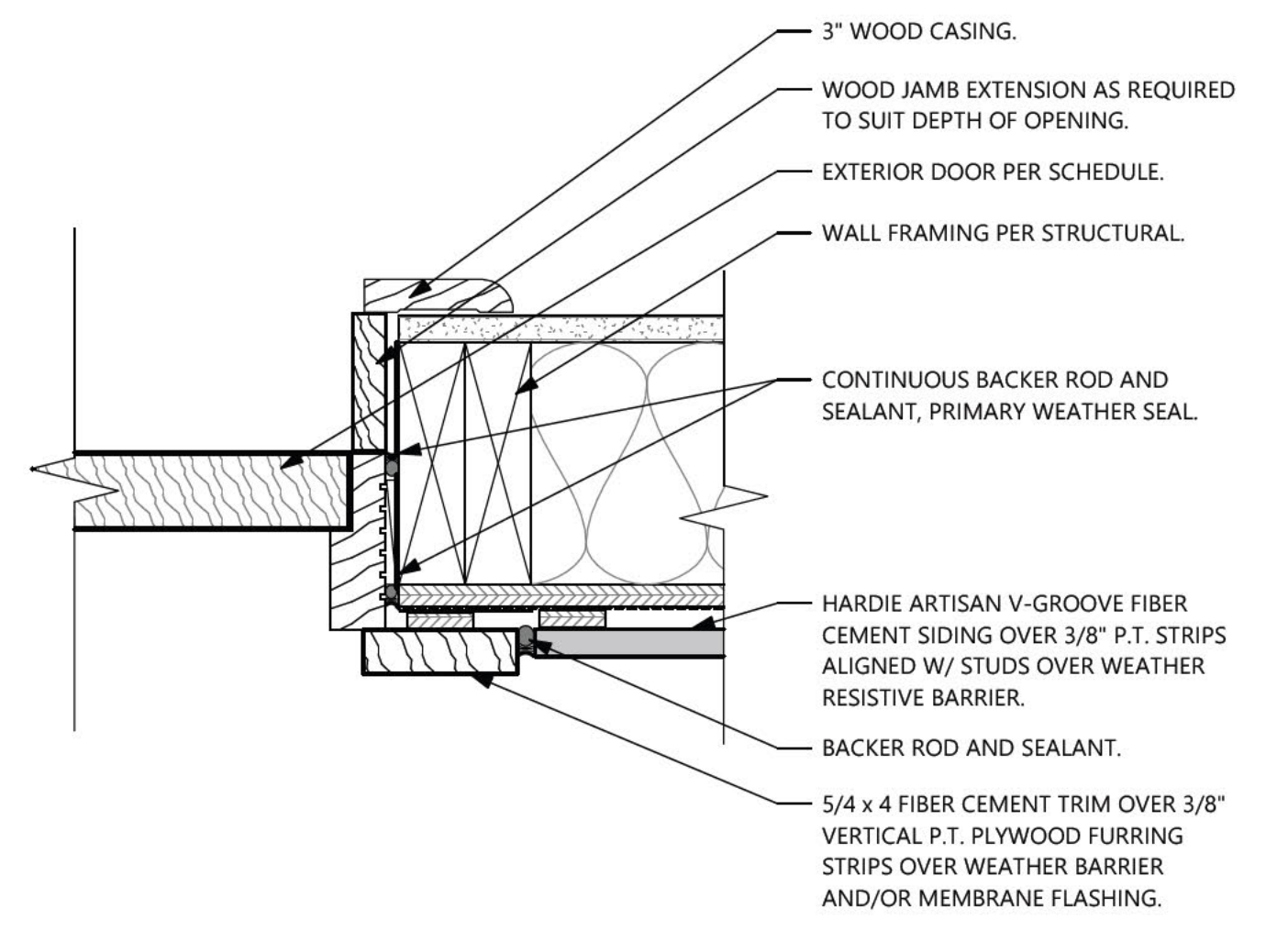

4 EXTERIOR WOOD DOOR JAMB
SCALE: 3" = 1'-0"

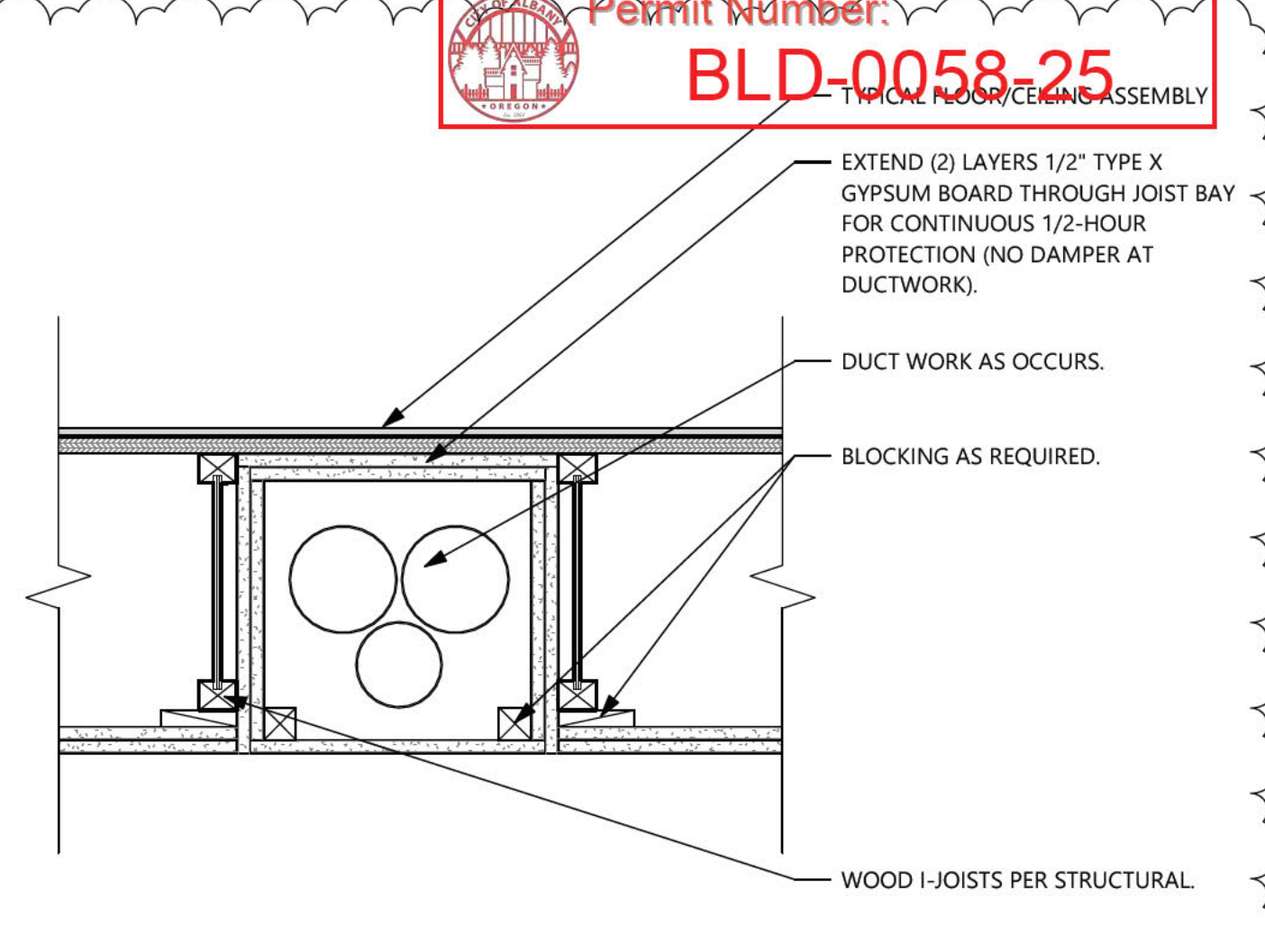

3 EXHAUST DUCTS IN JOIST BAY
SCALE: 1 1/2" = 1'-0"

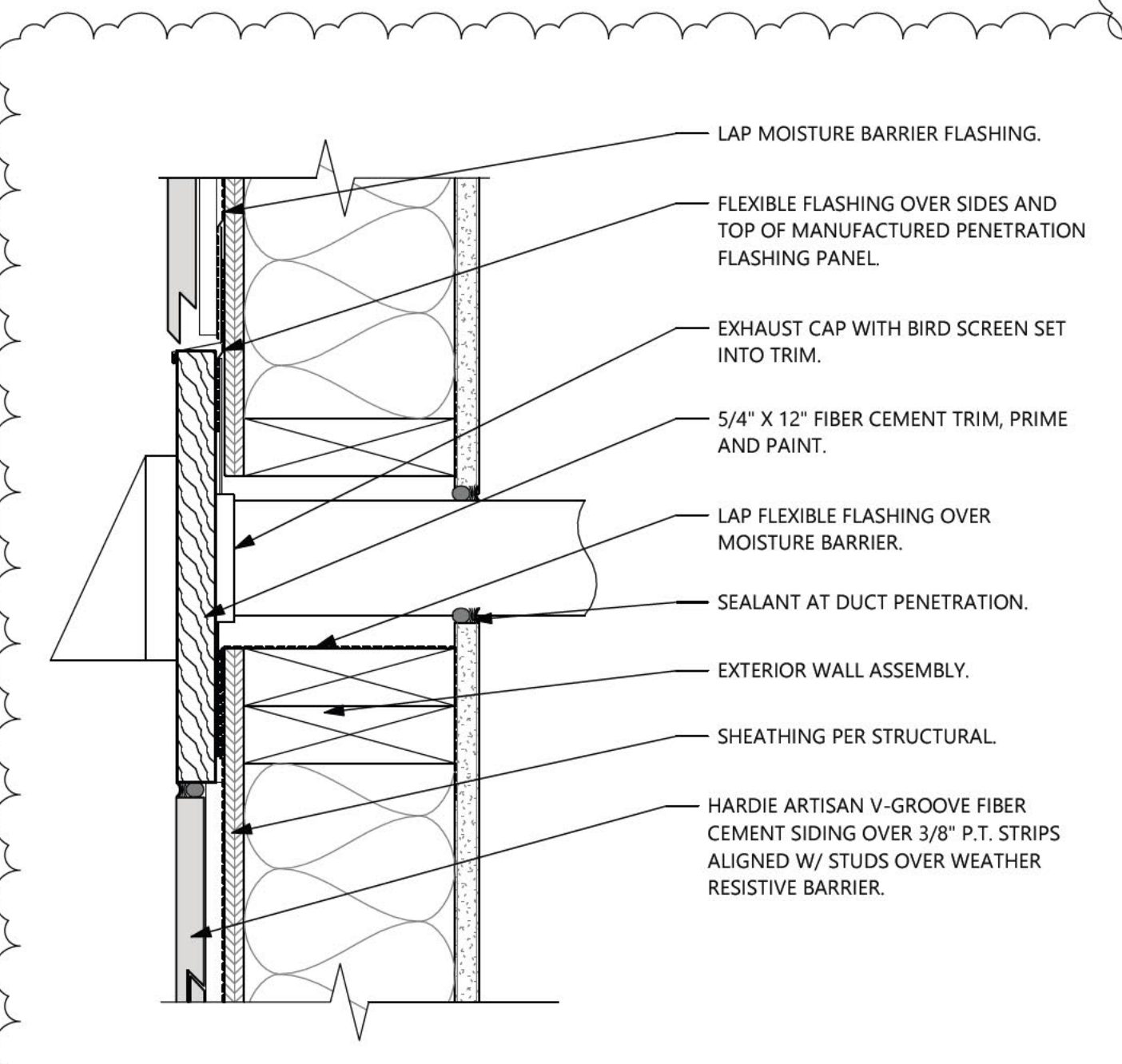

6 EXHAUST PENETRATION
SCALE: 3" = 1'-0"

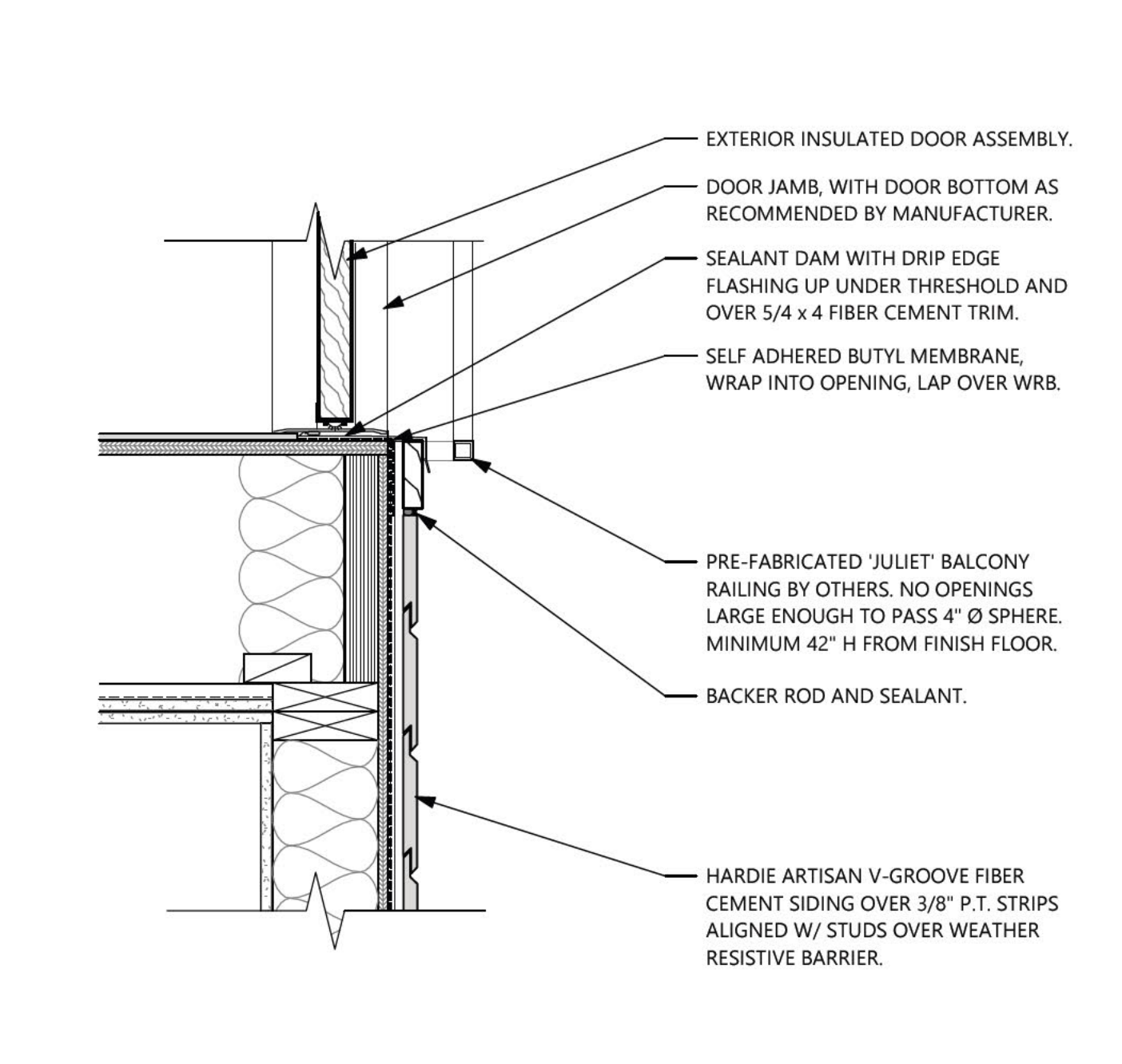

7 DOOR THRESHOLD AT JULIET BALCONY
SCALE: 1 1/2" = 1'-0"

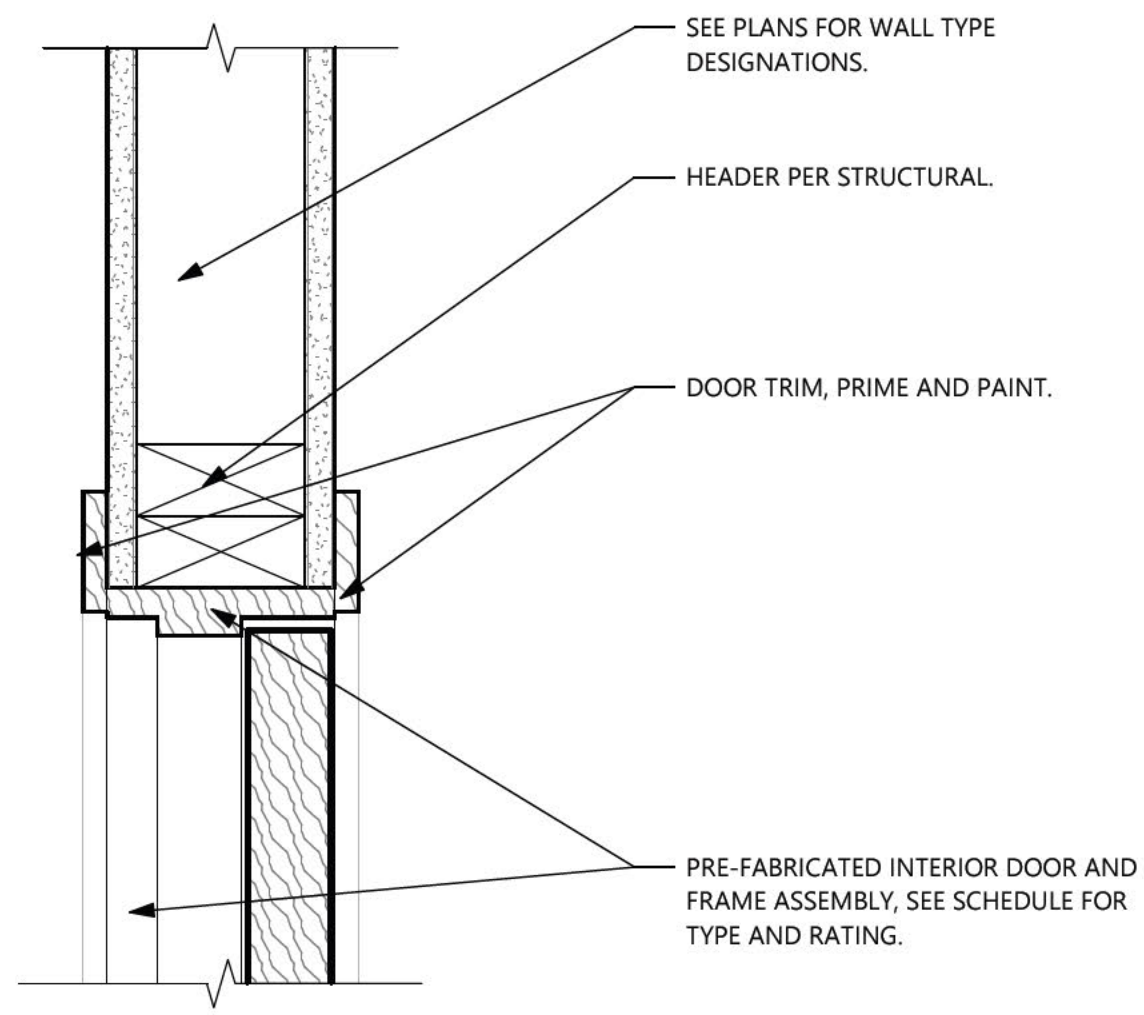

1 TYPICAL INTERIOR DOOR HEAD DETAIL
SCALE: 3" = 1'-0"

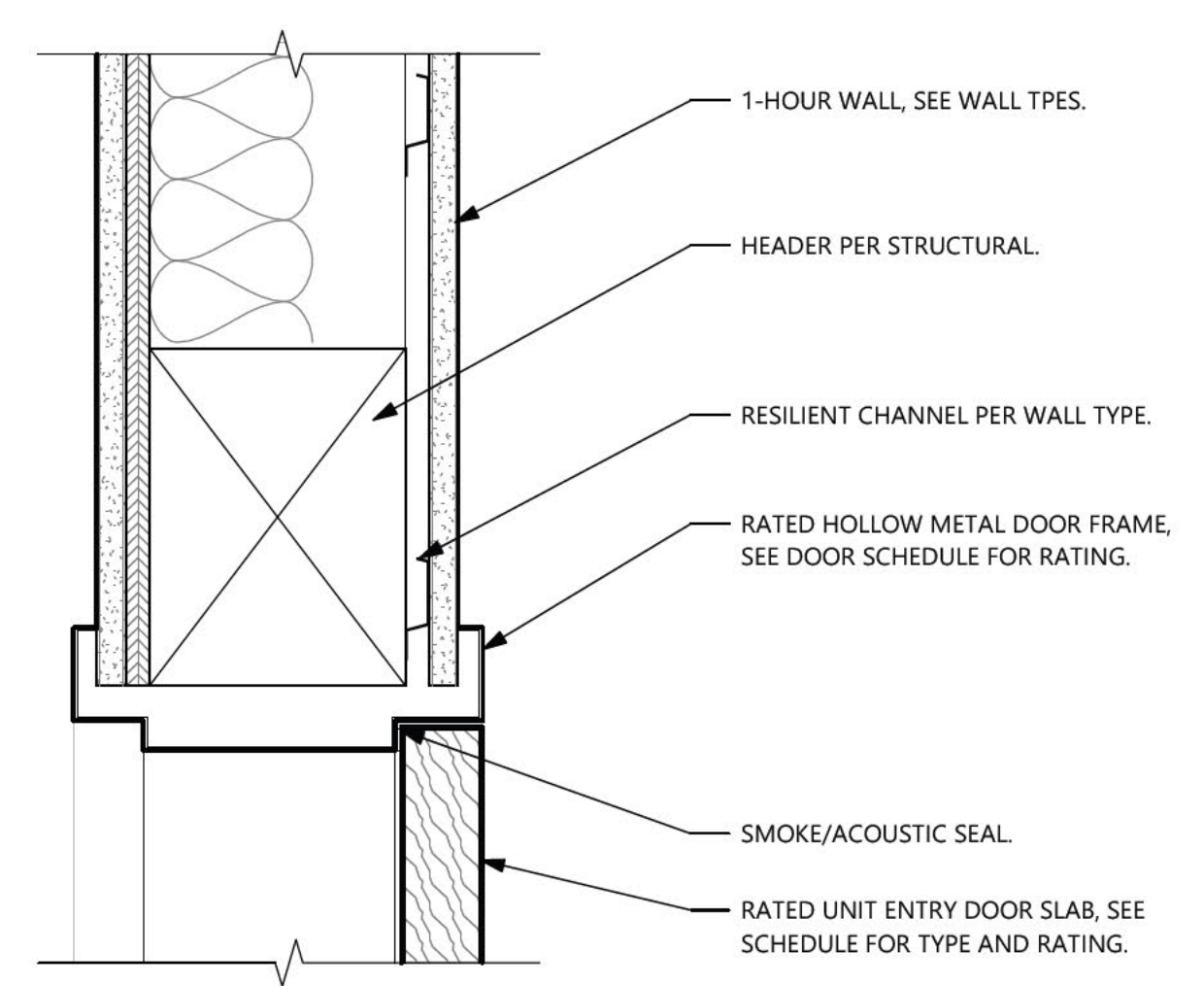

2 DOOR HEAD AT UNIT- CORRIDOR
SCALE: 3" = 1'-0"

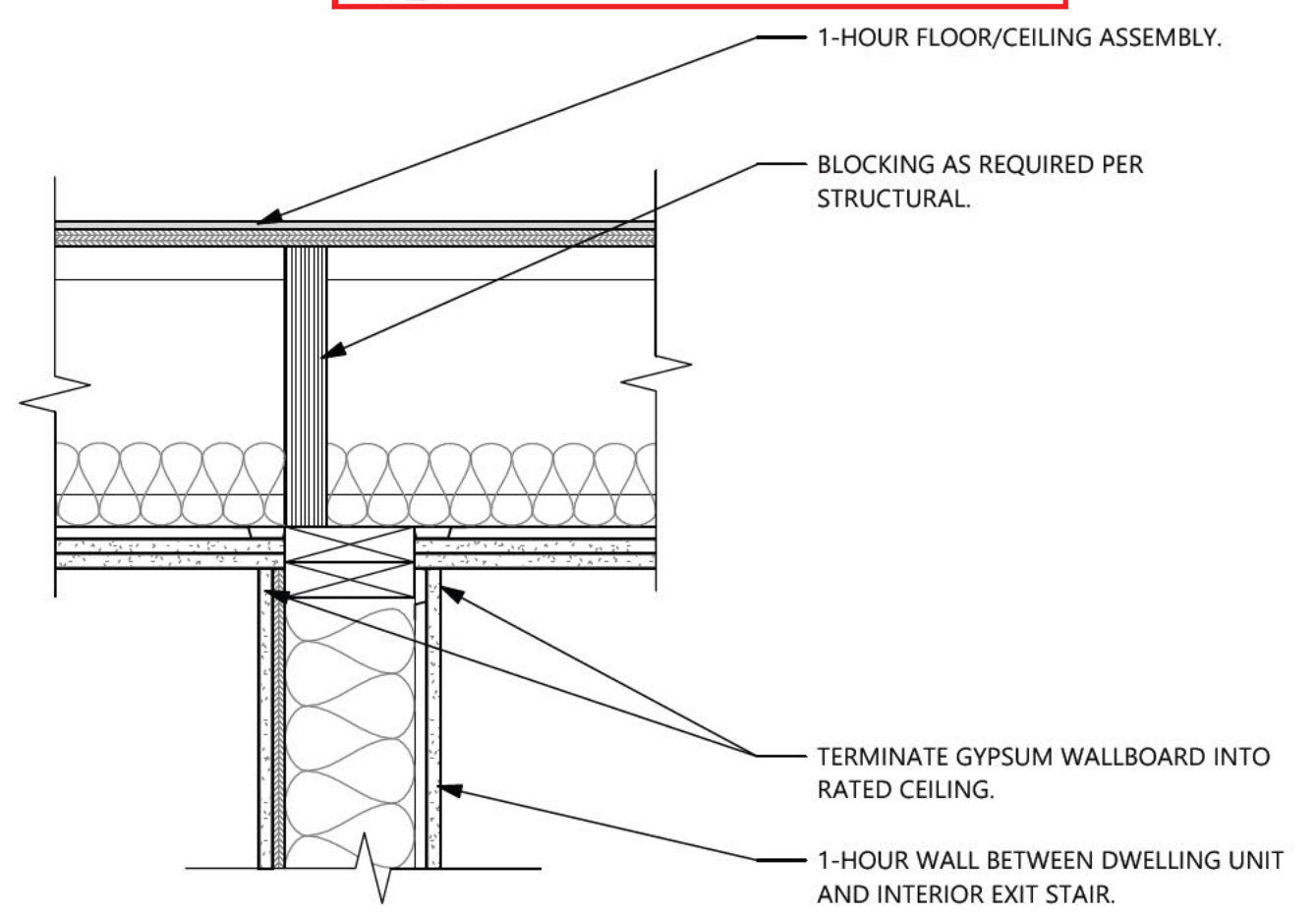

3 DEMISING WALL HEAD AT RATED FLOOR/CEILING
SCALE: 1 1/2" = 1'-0"

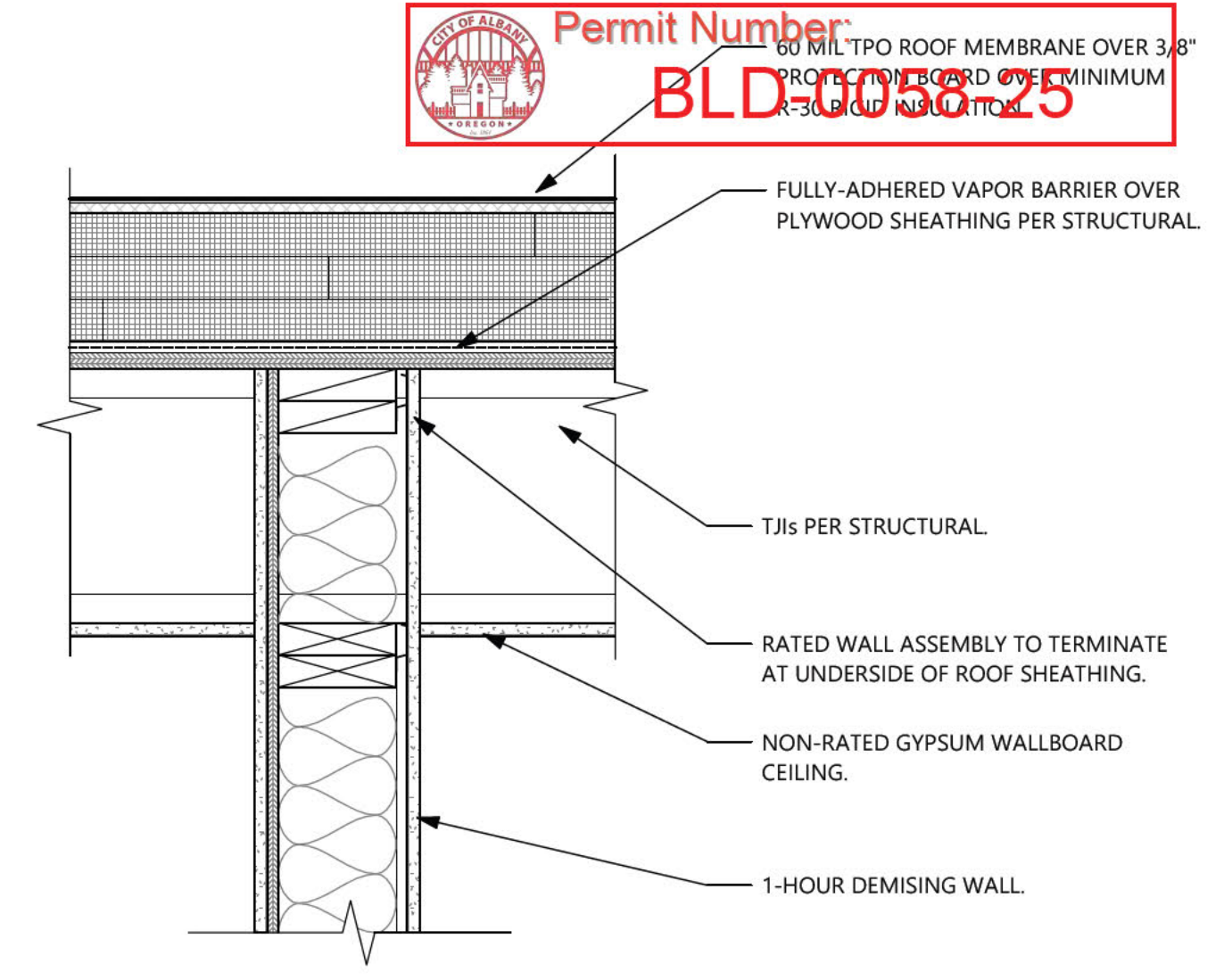

4 DEMISING WALL HEAD AT ROOF
SCALE: 1 1/2" = 1'-0"

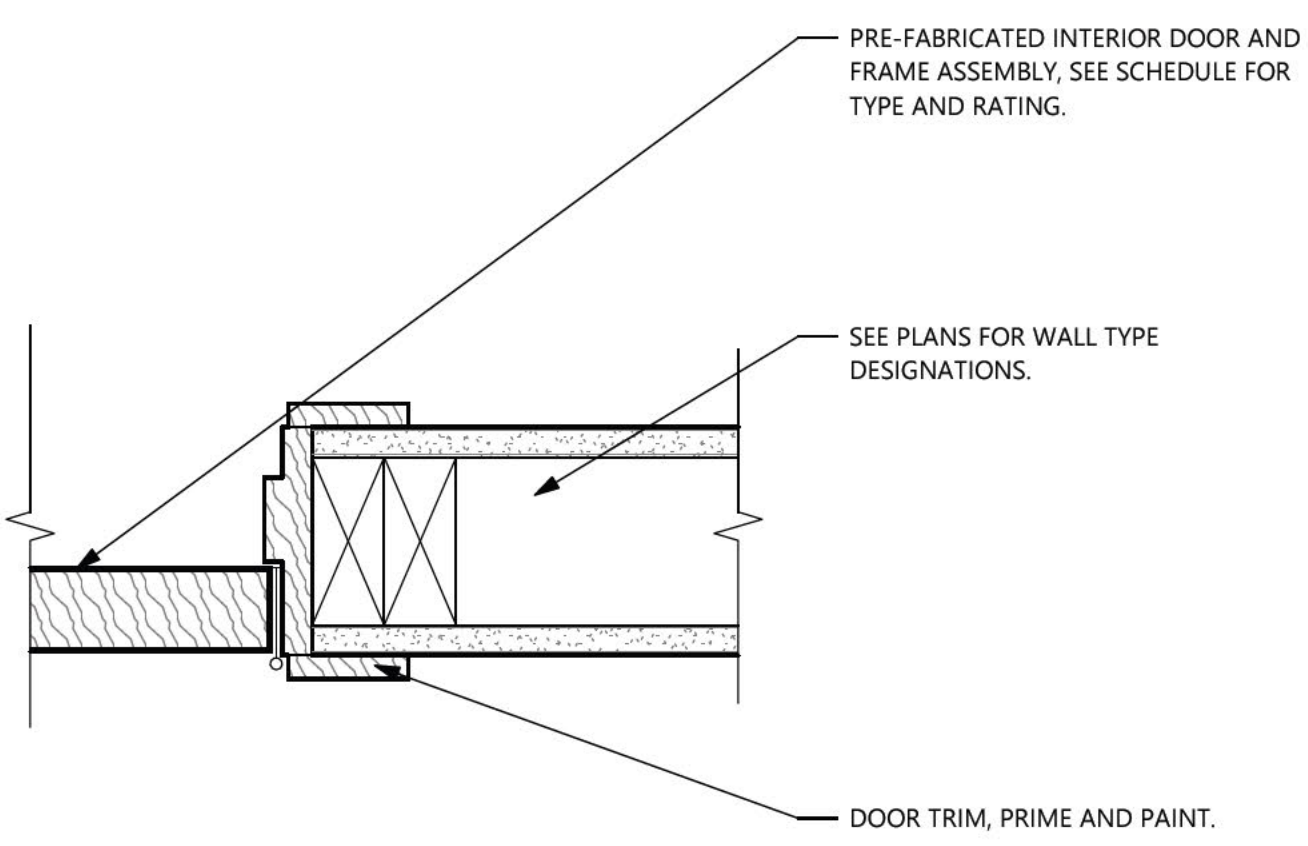

5 TYPICAL INTERIOR DOOR JAMB DETAIL
SCALE: 3" = 1'-0"

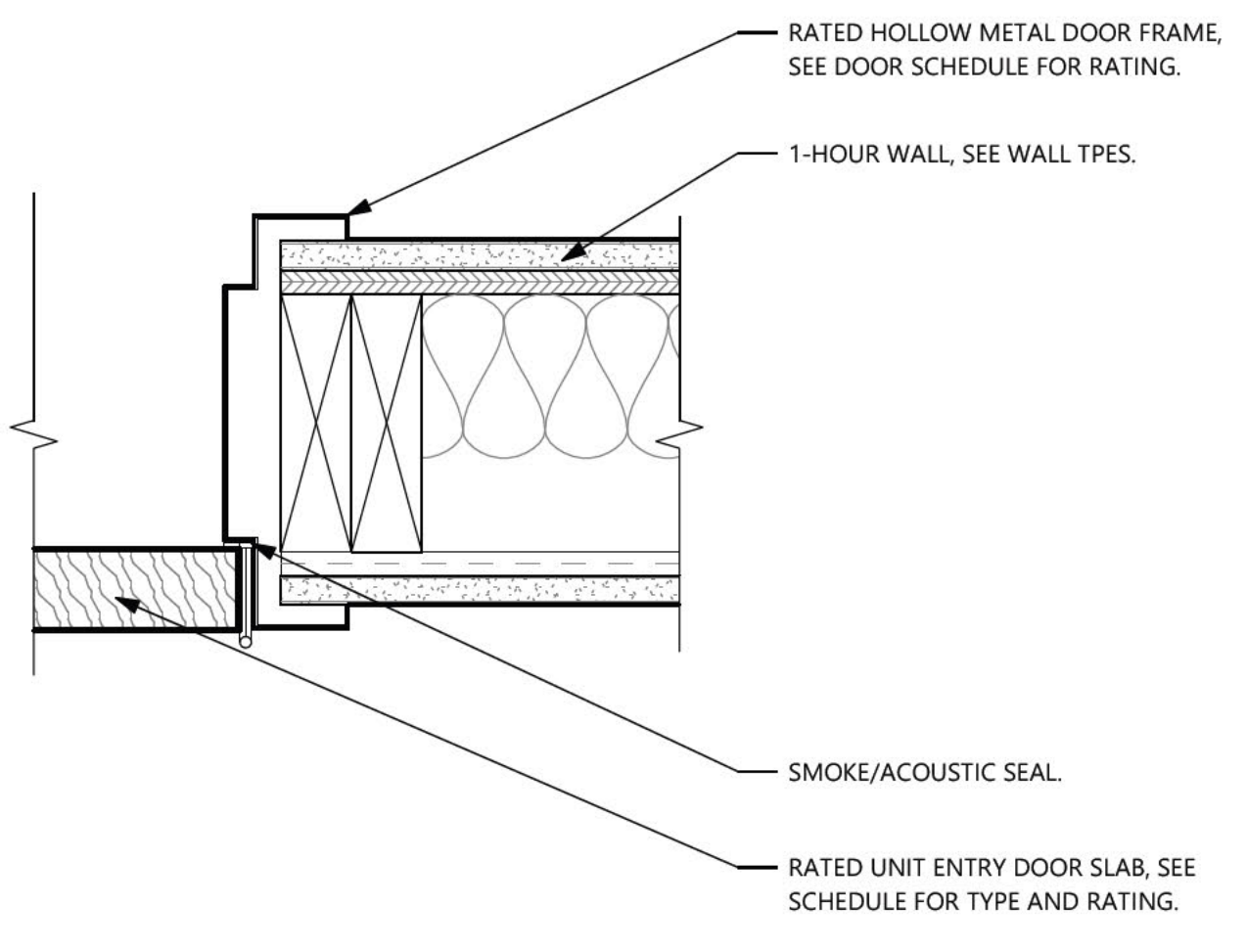

6 DOOR JAMB AT UNIT - CORRIDOR
SCALE: 3" = 1'-0"

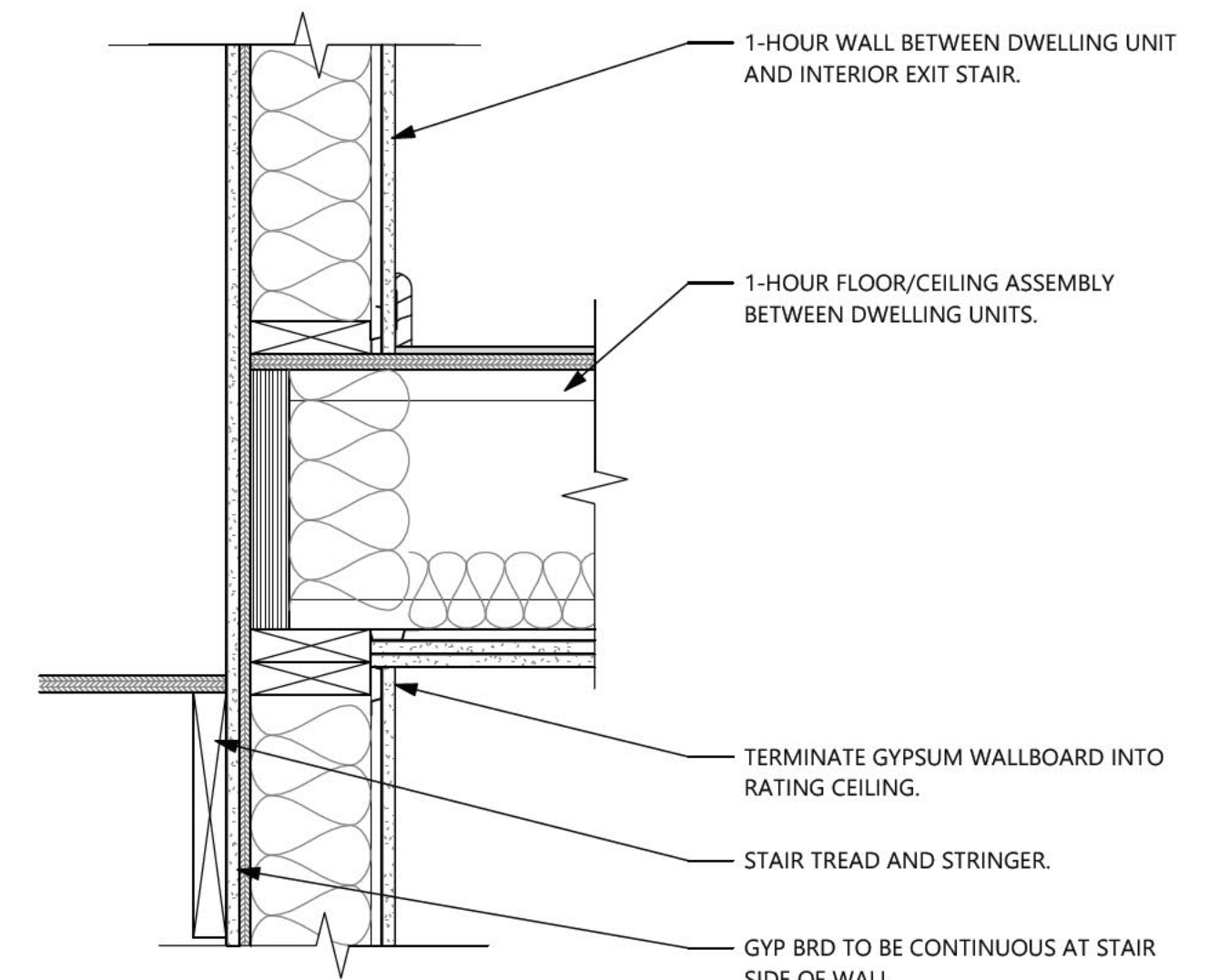

7 FIRE BARRIER CONTINUITY AT STAIR
SCALE: 1 1/2" = 1'-0"

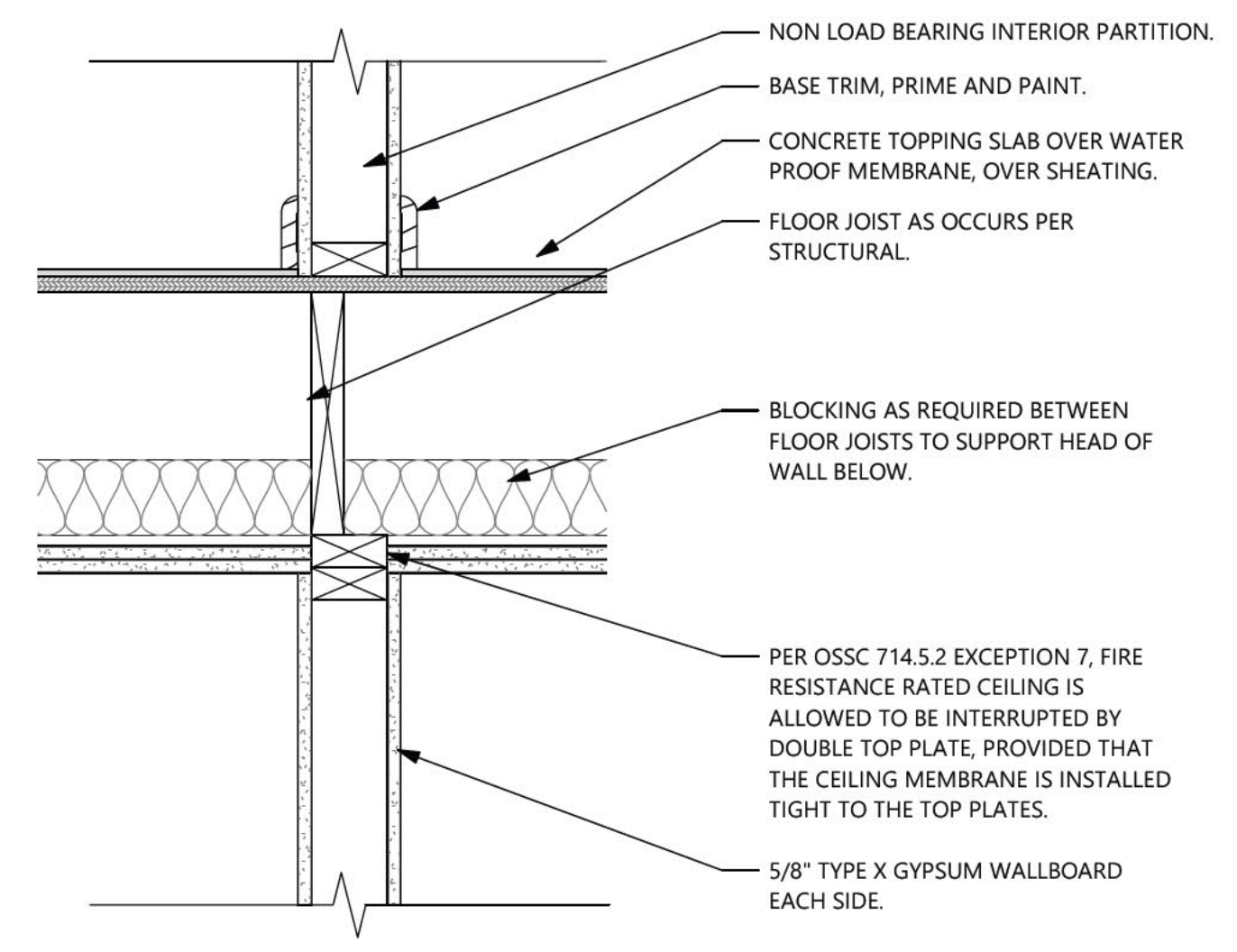

8 NON-RATED PARTITION AT RATED FLOOR/CEILING
SCALE: 1 1/2" = 1'-0"

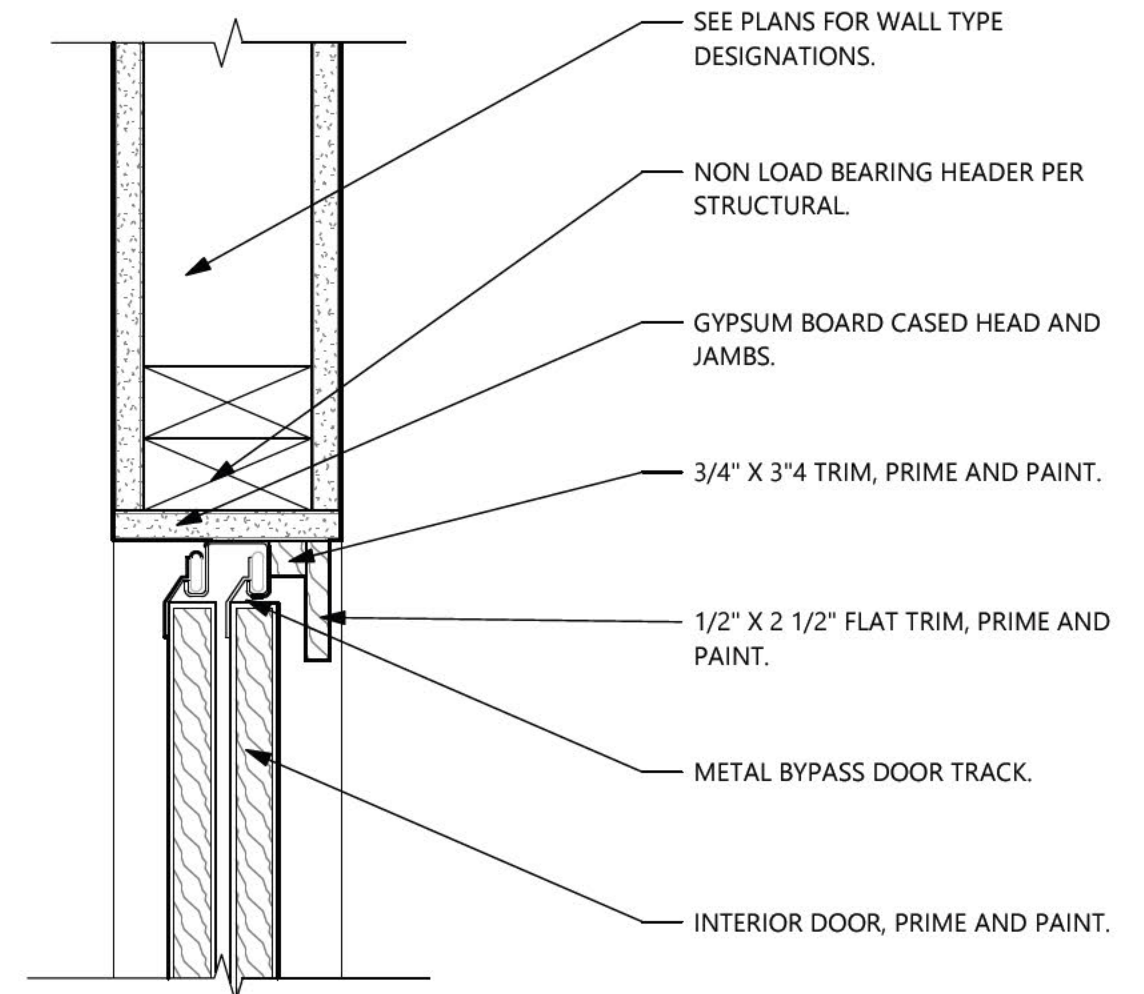

9 DOOR HEAD AT INTERIOR BYPASS
SCALE: 3" = 1'-0"

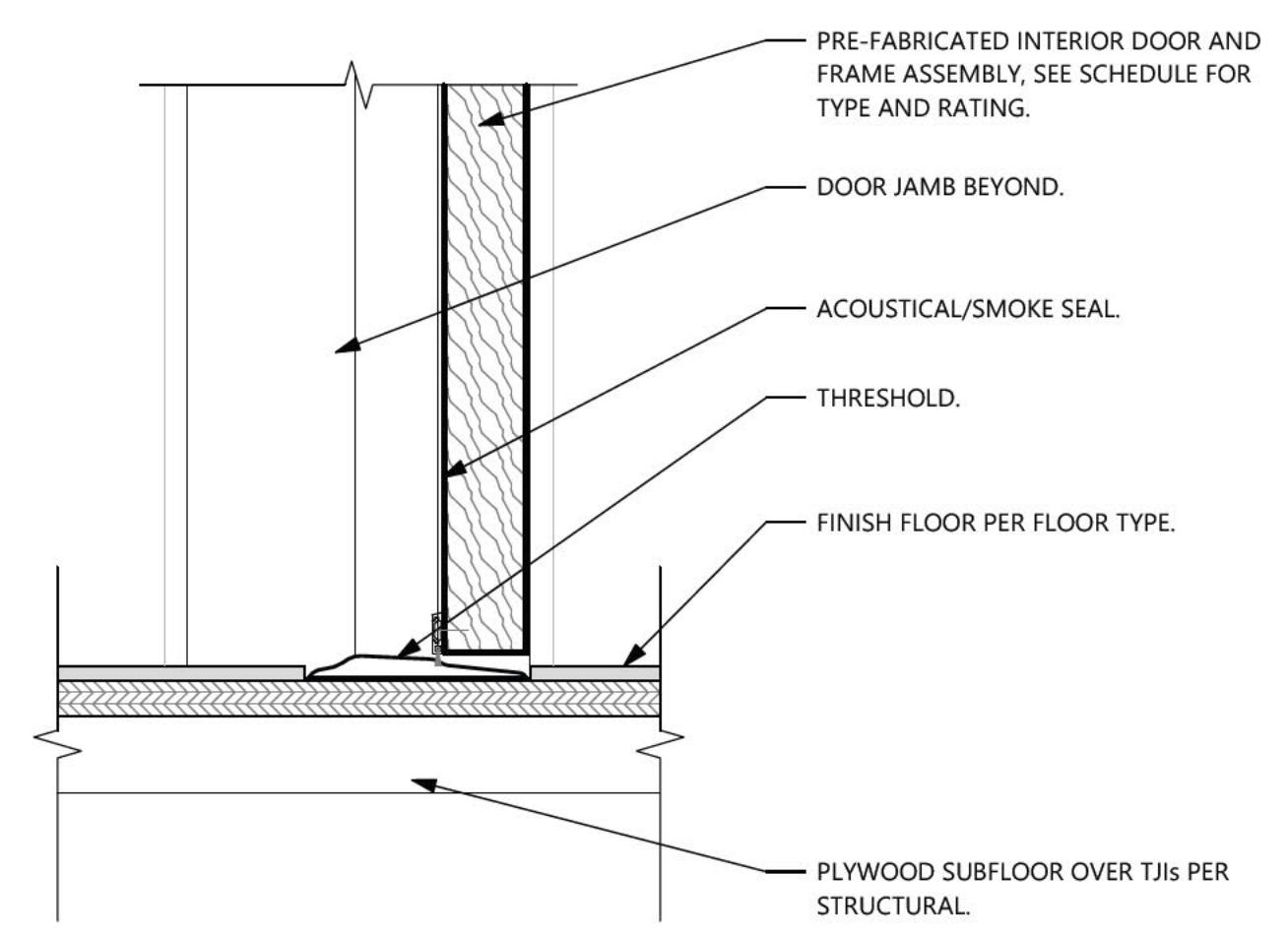

10 DOOR SILL AT UNIT ENTRY
SCALE: 3" = 1'-0"

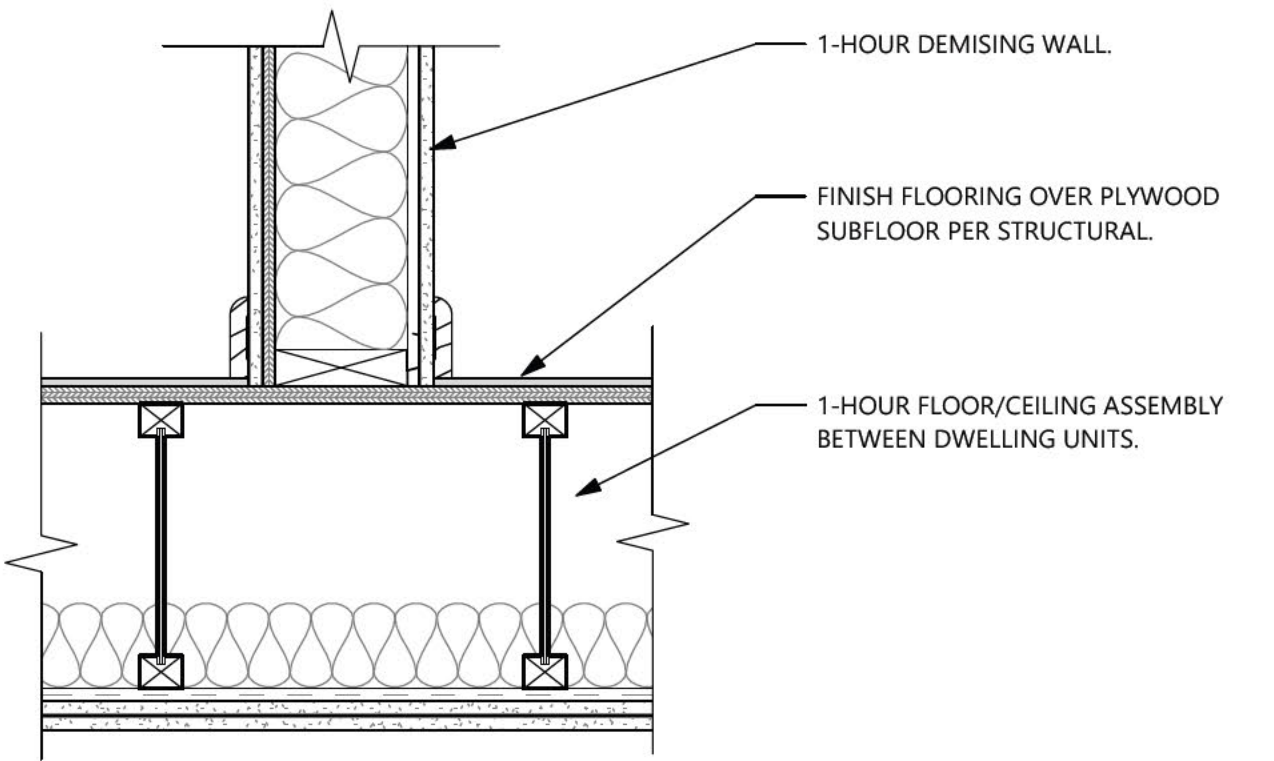

11 DEMISING WALL BASE AT RATED FLOOR/CEILING
SCALE: 1 1/2" = 1'-0"

REVISIONS:

SHEET:
A5.41

INTERIOR DETAILS

PROJECT # 2024-014
DATE: 3/4/2025

Revised Page
01/30/2026

Permit Number:
BLD-0058-25
PIPE RISER

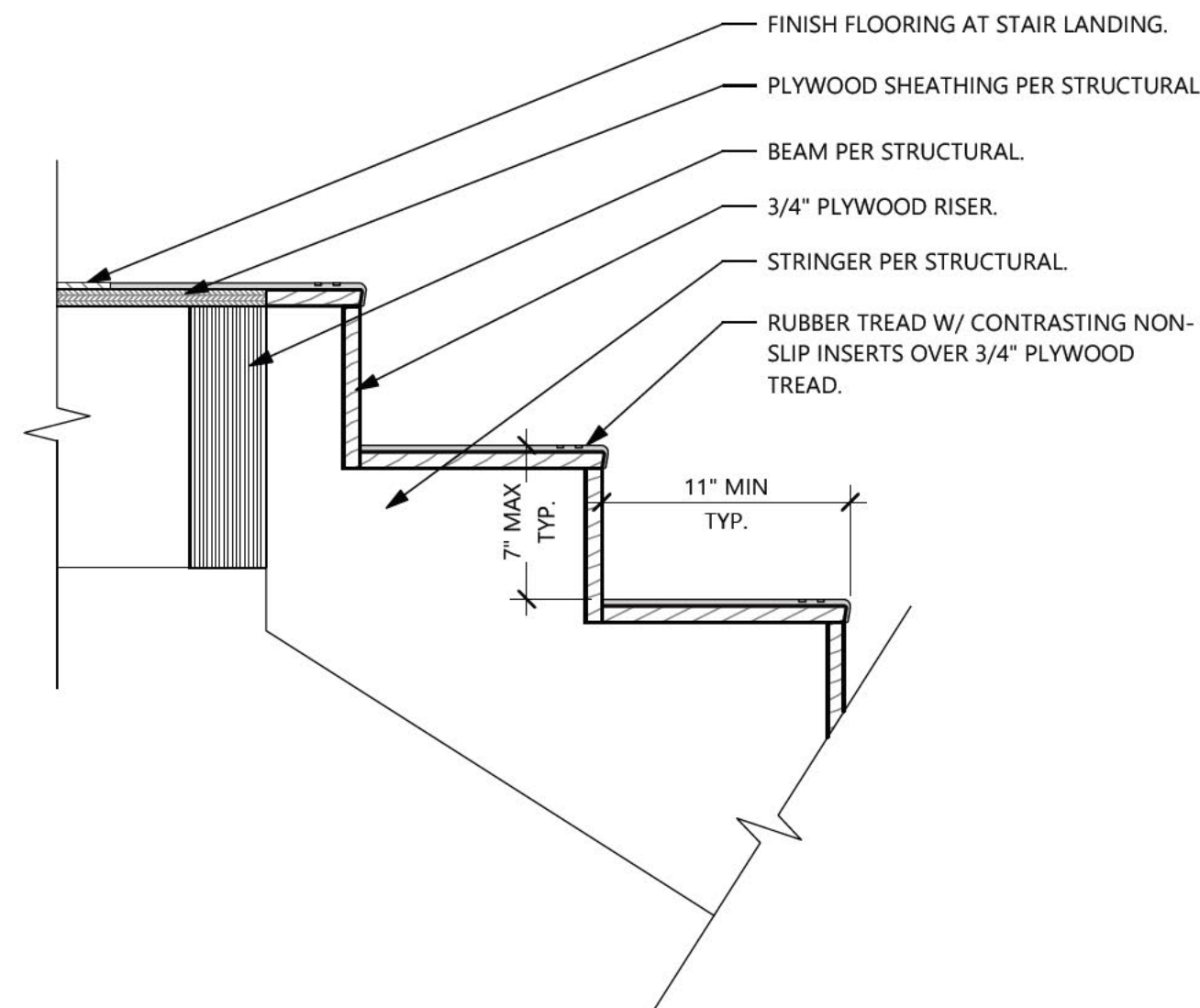

1 WOOD STAIR TOP AT LANDING
SCALE: 1 1/2" = 1'-0"

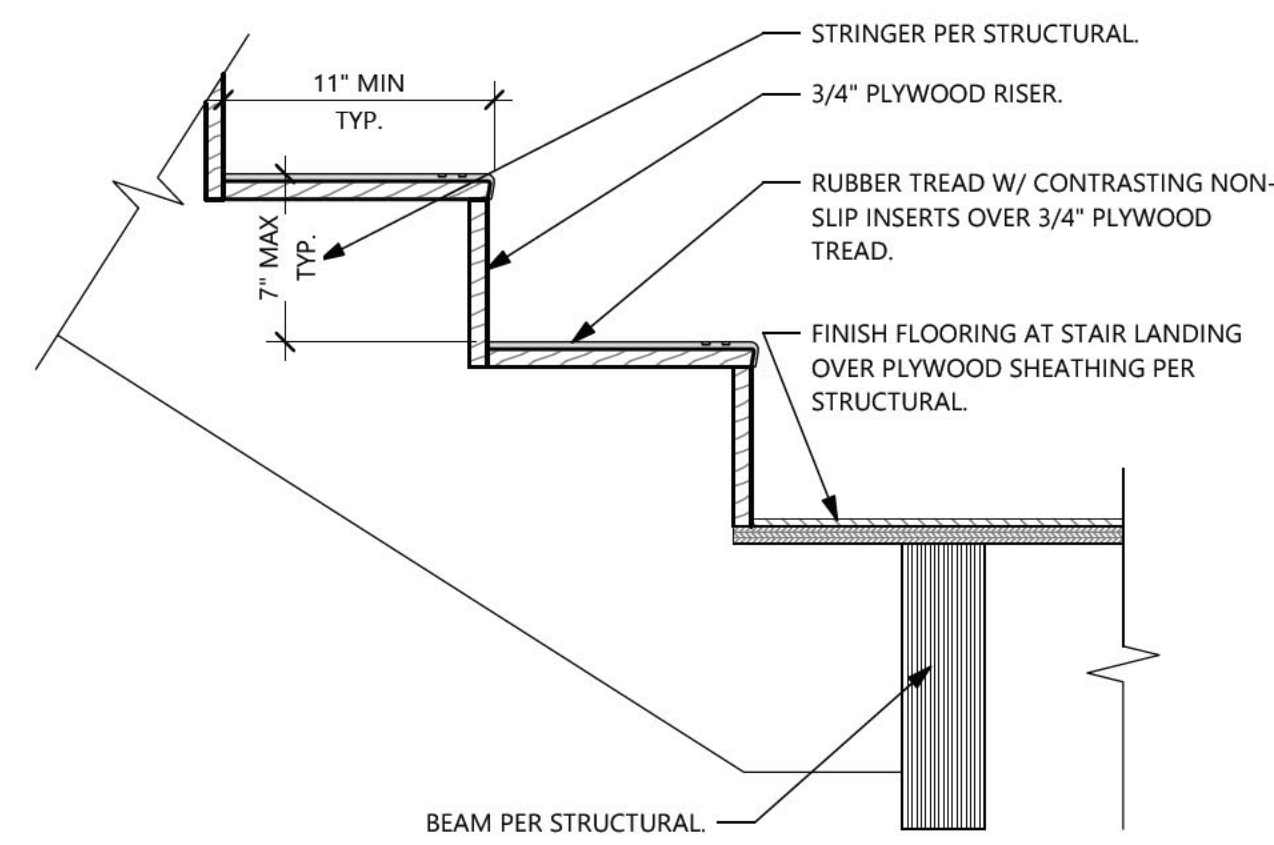

2 WOOD STAIR BOTTOM AT LANDING
SCALE: 1 1/2" = 1'-0"

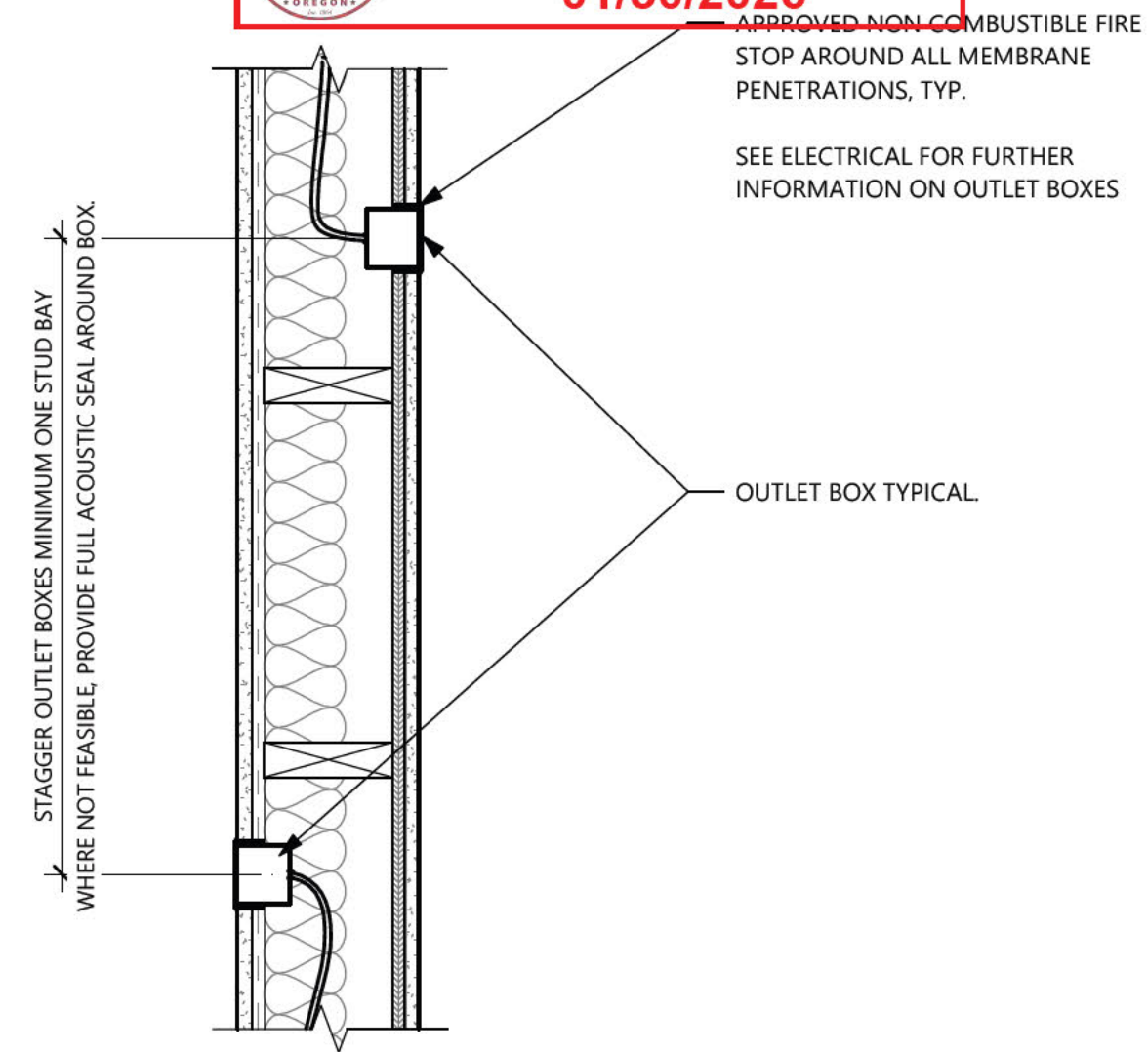

3 ELEC. PENETRATIONS AT INT. DEMISING WALLS
SCALE: 1 1/2" = 1'-0"

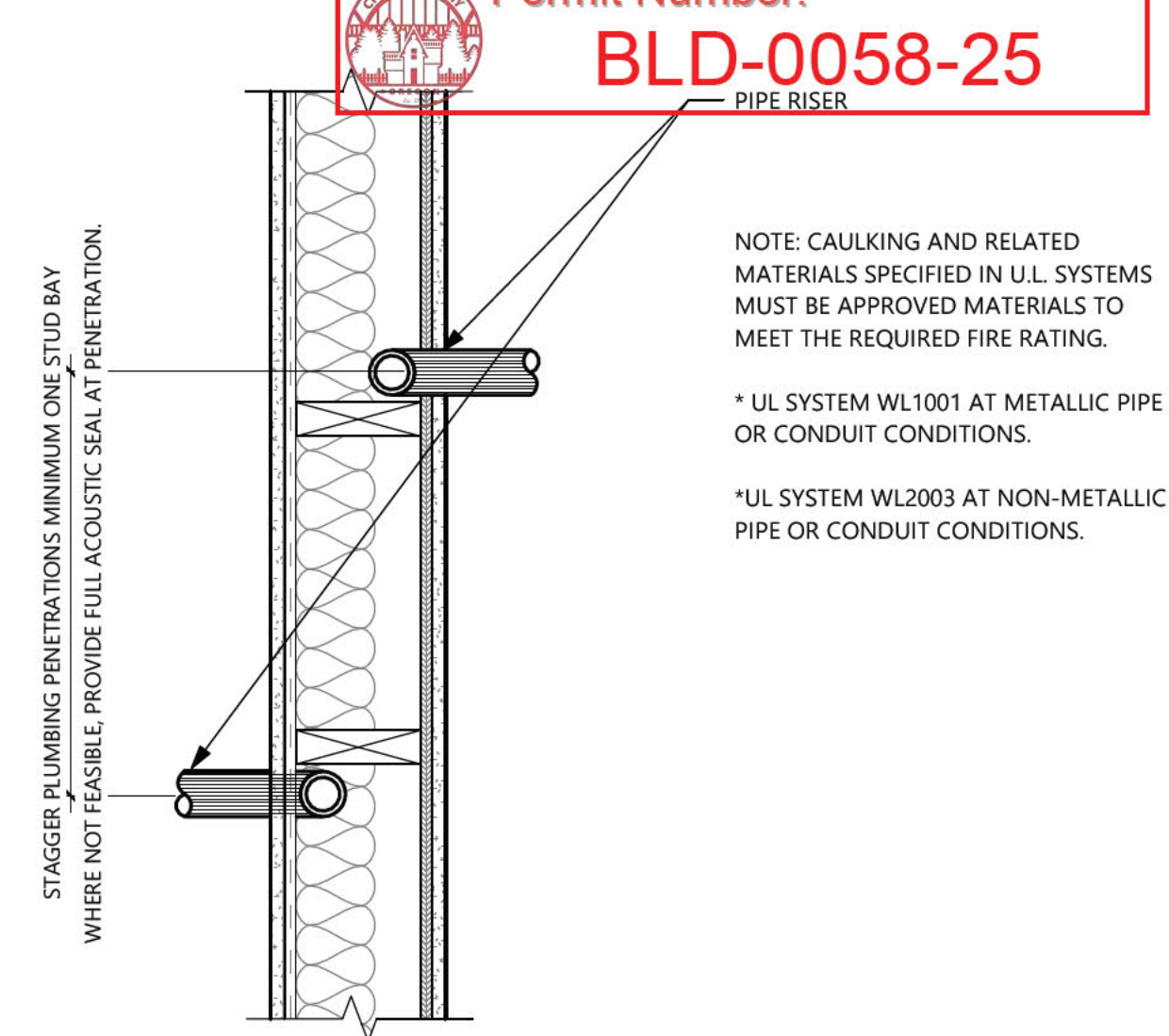

4 PLUMBING PENETRATIONS AT INT. DEMISING WALLS
SCALE: 1 1/2" = 1'-0"

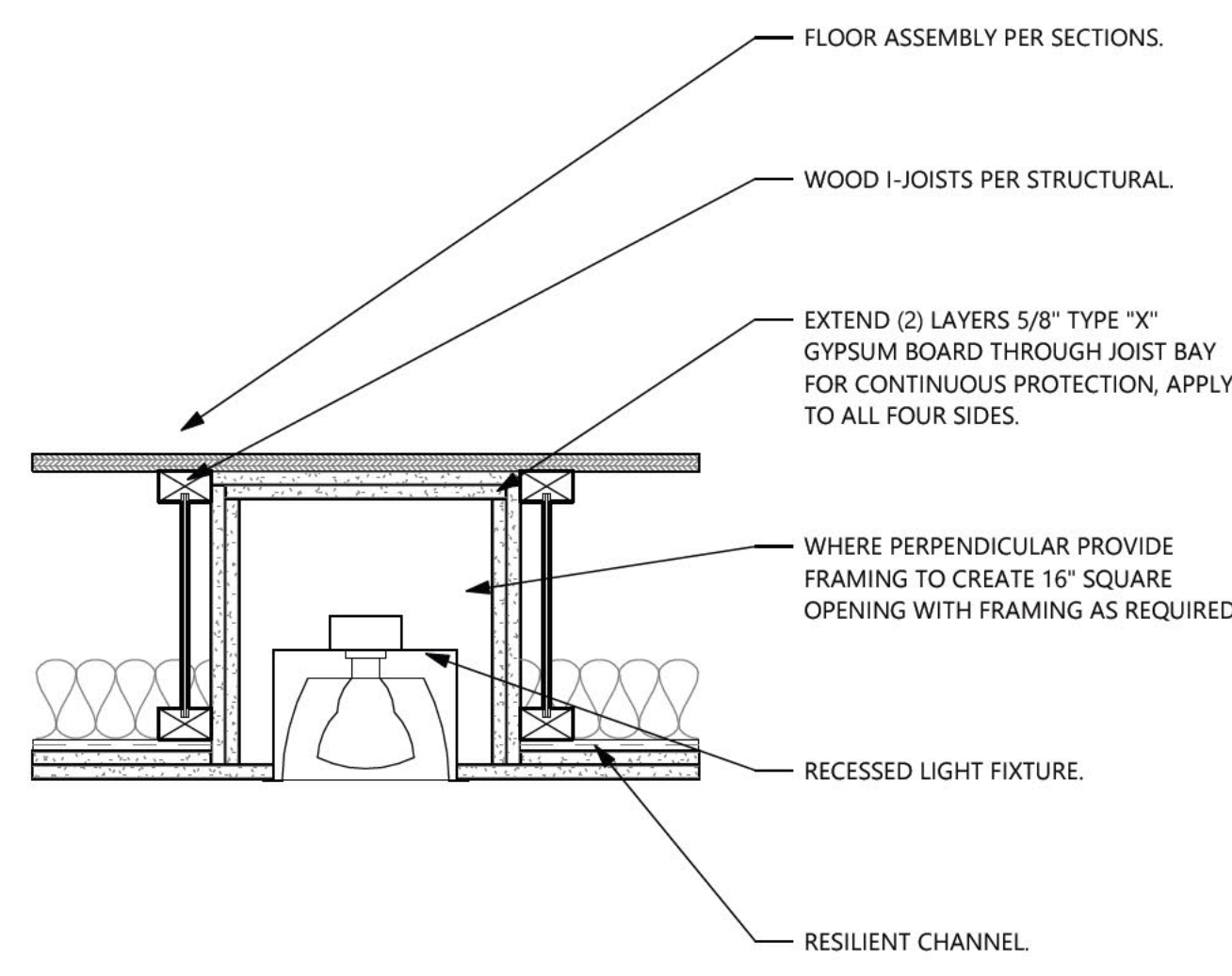

5 RECESSED CAN LIGHT AT JOIST BAY
SCALE: 1 1/2" = 1'-0"

LIFT
ARCHITECTURE
1130 Liberty St SE Suite 230 | Salem, OR 97302

REGISTERED ARCHITECT
MATTHEW D. JOHNSON
SALEM, OREGON
13288
STATE OF OREGON

ADDITION & REMODEL
BRIGGS BUILDING
333 W 1ST AVE ALBANY OR. 97321

REVISIONS:
4 1/28/2026 Sprinklers/Elevations

SHEET:
A5.42
INTERIOR DETAILS

PROJECT # 2024-014
DATE: 3/4/2025

Revised Page
01/30/2026

Permit Number:
BLD-0058-25

DOOR SCHEDULE														
Door Number	Width	Height	Door Type	Door Mat'l	Door Core	Door Glass Type	Door Finish	Frame Mat'l	Detail Head	Detail Jamb	Detail Sill	Fire Rating	Hardware Group	Remarks
(E) 101-2	2' - 10"	6' - 8"	-	-	-	-	-	-	-	-	-	-	HW-7	
101-1	3' - 3 5/16"	8' - 0"	S-1	WD	INSUL	IG-3	Paint	WD	1/A5.21	5/A5.21	9/A5.21	-	HW-3	WOOD STOREFRONT DOOR
102-1	3' - 0"	6' - 8"	D-1	WD	INSUL	-	Paint	WD	1/A5.41	5/A5.41	-	-	HW-4	
105-1	3' - 0"	6' - 8"	D-1	WD	SOLID	-	Paint	WD	1/A5.41	5/A5.41	-	-	HW-6	
109-1	3' - 0"	6' - 8"	D-1	WD	SOLID	-	Paint	WD	1/A5.41	5/A5.41	-	20 MIN	HW-6	
DOOR A	3' - 0"	6' - 8"	D-1	WD	SOLID	-	Paint	WD	2/A5.41	6/A5.41	10/A5.41	20 MIN	HW-2	UNIT ENTRY DOOR
DOOR B	2' - 8"	6' - 8"	D-1	WD	HOL	-	Paint	WD	1/A5.41	5/A5.41	-	60 MIN	HW-1	
DOOR C	2' - 6"	6' - 8"	D-1	WD	HOL	-	Paint	WD	1/A5.41	5/A5.41	-	-	HW-1	
DOOR D	2' - 4"	6' - 8"	D-1	WD	HOL	-	Paint	WD	1/A5.41	5/A5.41	-	-	HW-1	
DOOR E	5' - 0"	6' - 8"	D-3	WD	HOL	-	Paint	WD	9/A5.41	-	-	-	HW-SL-1	
DOOR F	5' - 0"	6' - 8"	D-4	WD	HOL	-	Paint	WD	-	-	-	-	HW-SL-2	
DOOR G	4' - 0"	6' - 8"	D-4	WD	HOL	-	Paint	WD	-	-	-	-	HW-SL-2	
DOOR H	2' - 8"	6' - 8"	D-1	WD	INSUL	-	Paint	WD	1/A5.22	2/A5.21	-	-	HW-5	
DOOR I	5' - 8"	7' - 0"	D-5	WD	INSUL	IG-3	Paint	WD	2/A5.22	4/A5.22	7/A5.22	-	HW-8	

HARDWARE SCHEDULE

HW-1	HW-2	HW-3	HW-4
1 LATCHSET, PASSAGE 1 LEVER HANDLE SET 3 HINGES	1 LOCKSET 1 LEVER HANDLE SET 3 SPRING HINGES 1 SMOKE SEAL 1 DOOR SWEEP	PROVIDED BY MANUFACTURER: 3 HINGES 1 EMERGENCY EGRESS HARDWARE 1 LEVER HANDLE 1 WEATHERSTRIPPING 1 CLOSER	3 HINGES 1 LEVER HANDLE, SET W/ INTEGRAL THUMB LATCH AND OCCUPANCY INDICATOR 1 DOOR STOP 1 CLOSER
HW-5	HW-SL-1	HW-SL-2	HW-6
1 LEVER HANDLE W/ LOCKSET 3 HINGES 1 WEATHERSTRIPPING	1 BY-PASS DOOR TRACK KIT 1 PAIR FLUSH CUP PULLS	INTEGRAL HARDWARE BY DOOR SUPPLIER	1 LOCKSET, STORAGE 1 LEVER HANDLE SET 3 HINGES
HW-7	HW-8		
EXISTING DOOR HARDWARE TO REMAIN. VERIFY WORKING CONDITION.	1 LEVER HANDLE W/ LOCKSET 6 HINGES 2 WEATHERSTRIPPING		

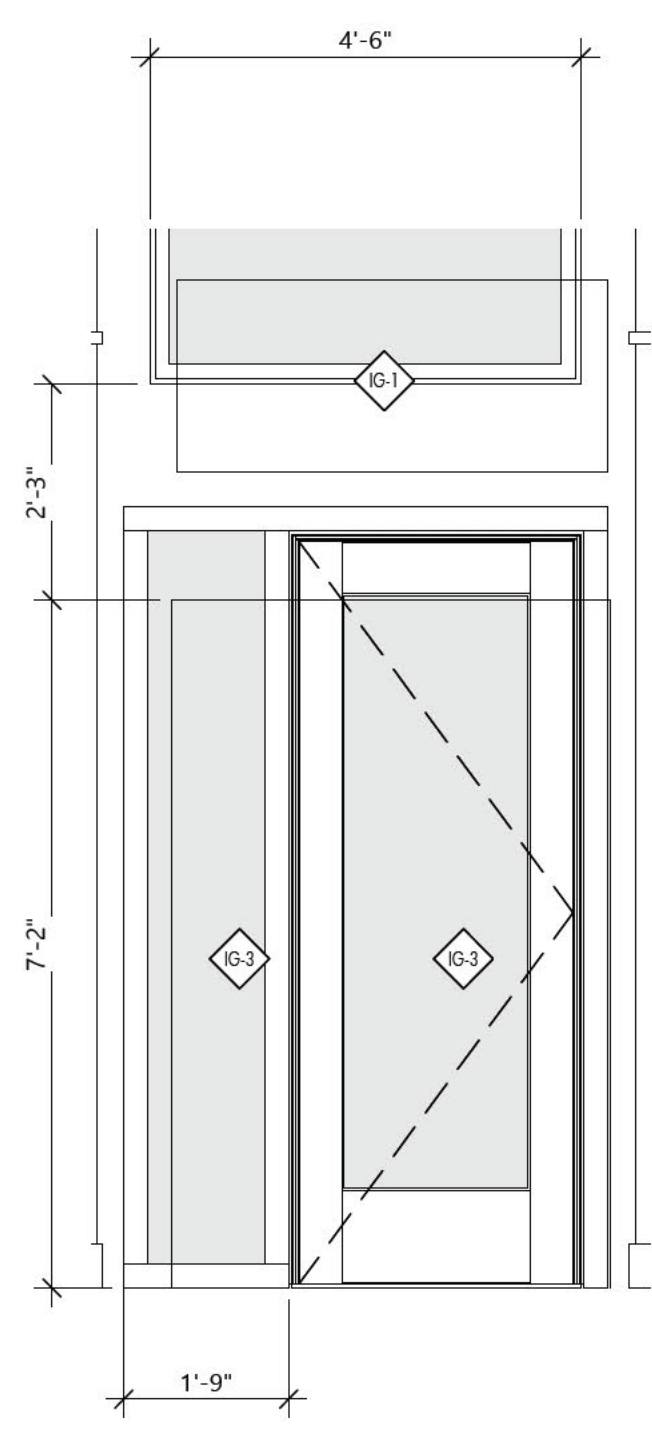

S-1

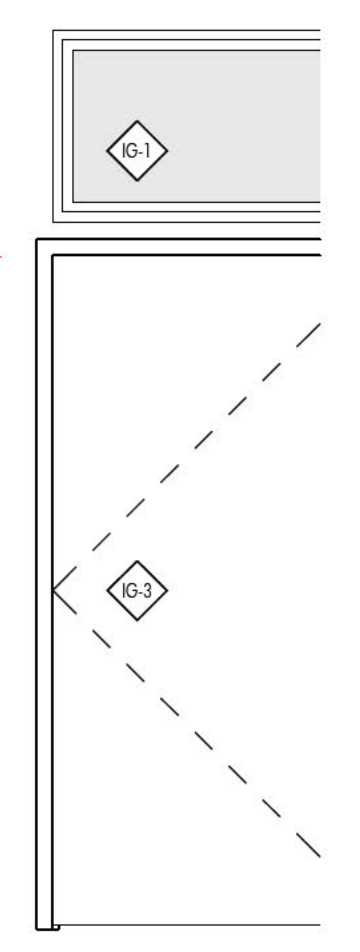

S-2

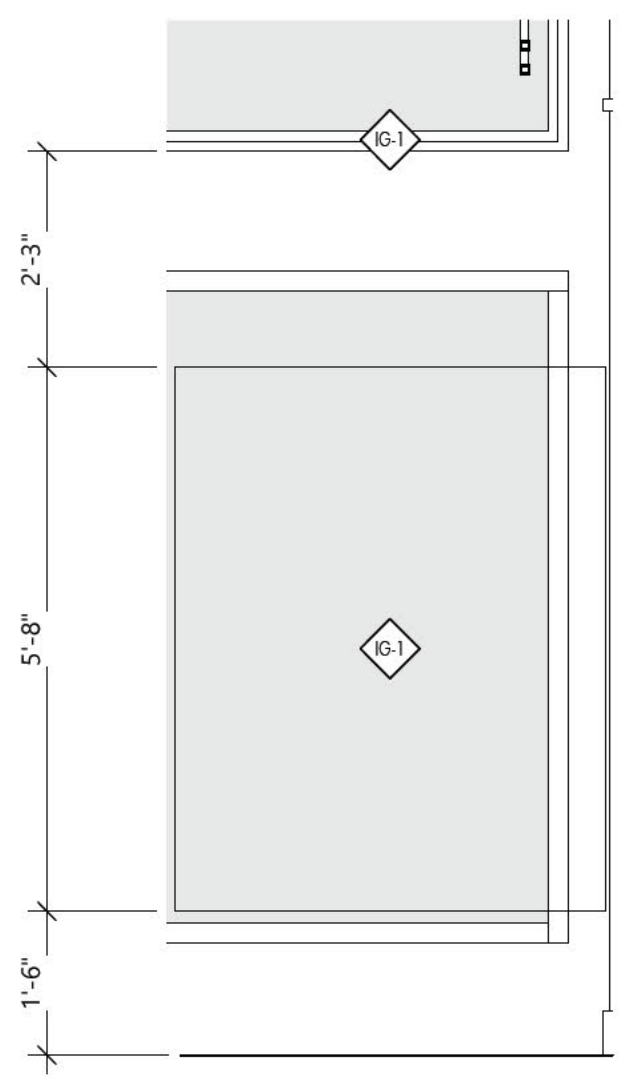

W-1

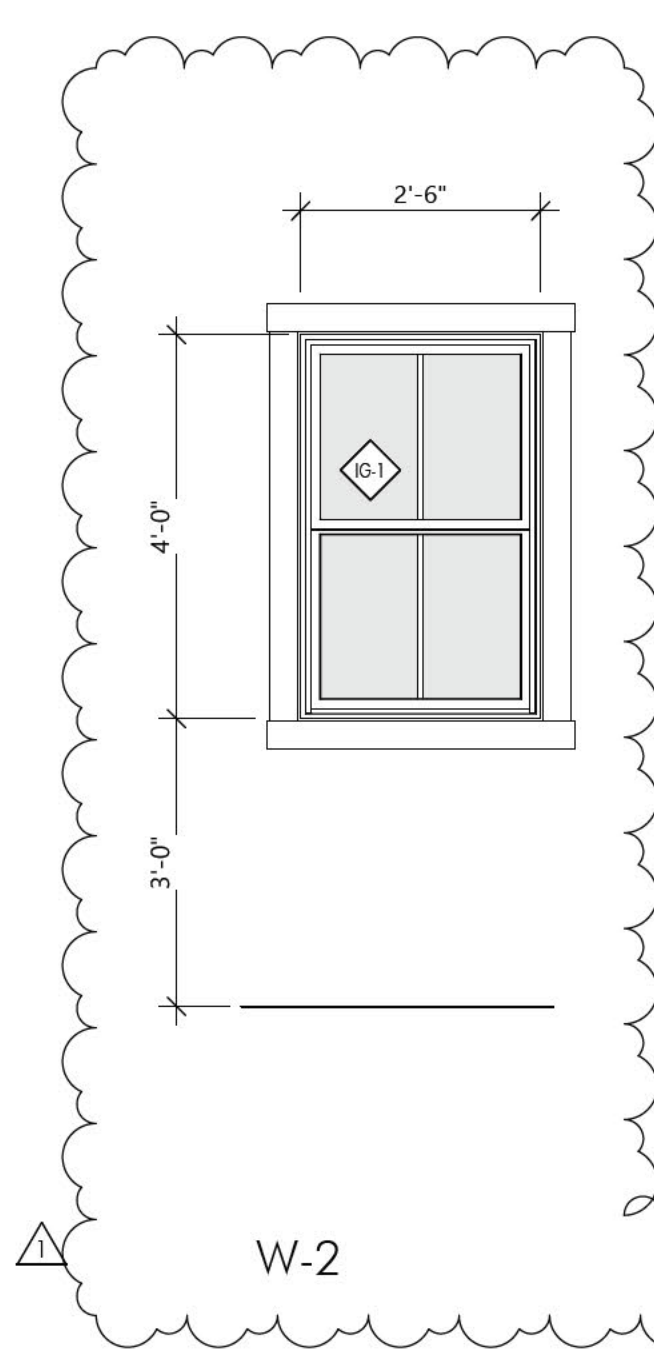

W-2

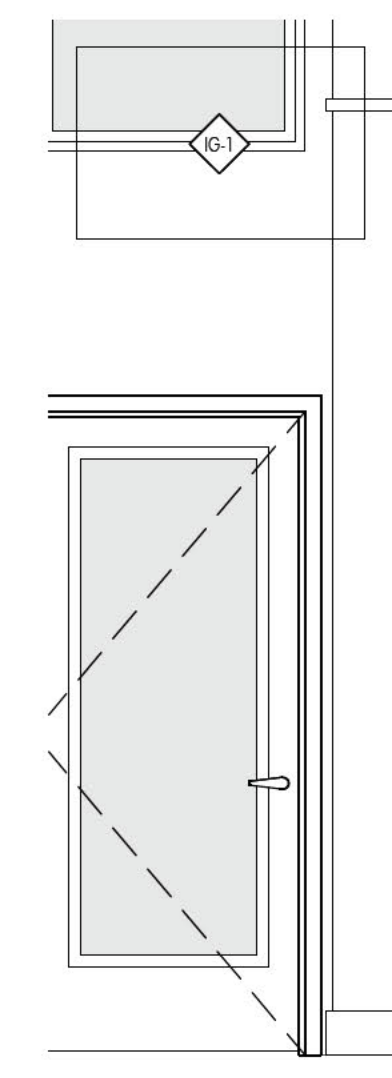

W-3

GLAZING TYPES:

- IG-1 INSULATED, LOW-E, NO TINT; TYPE IG-1. U - VALUE 0.350 SHGC 0.40
- IG-3 TEMPERED, INSULATED, LOW-E, NO TINT; TYPE IG-3. U - VALUE 0.350 SHGC 0.40

1 STOREFRONT ELEVATIONS
SCALE: 1/2" = 1'-0"

2 WINDOW ELEVATIONS
SCALE: 1/2" = 1'-0"

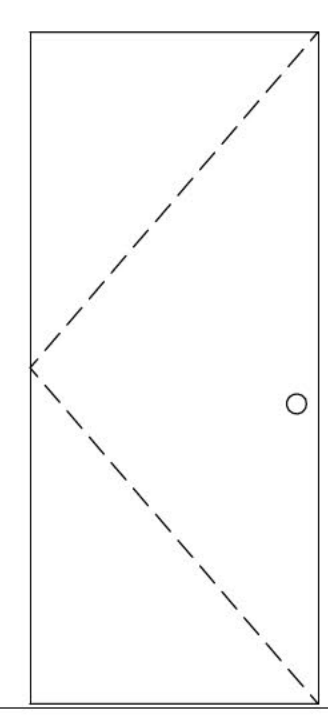

D-1

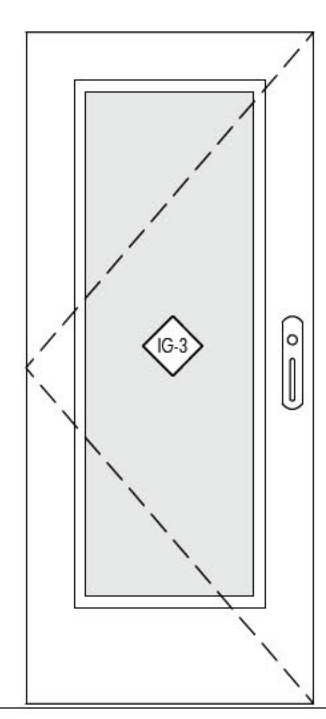

D-2

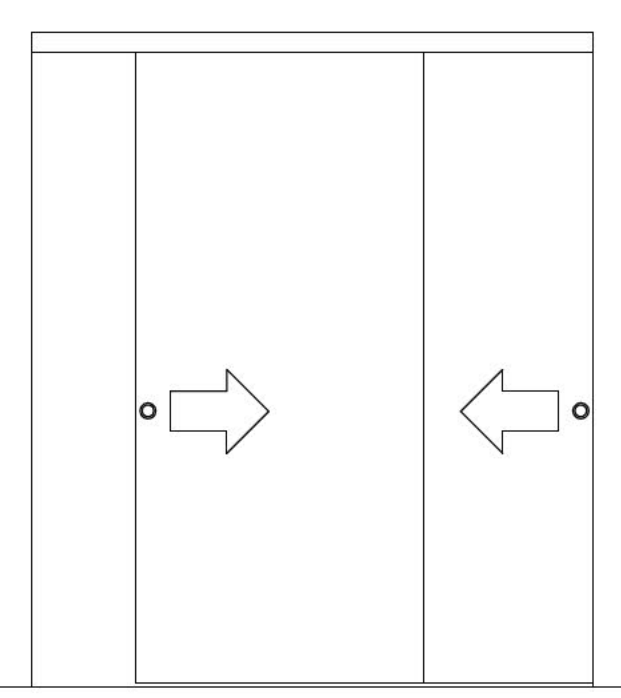

D-3

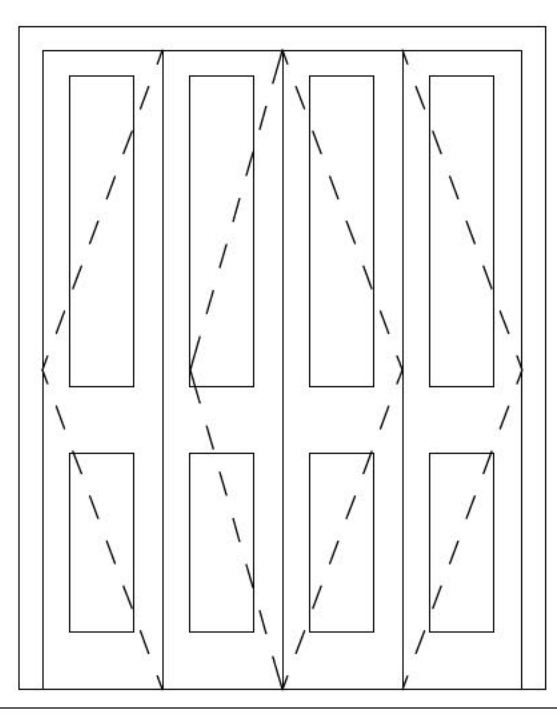

D-4

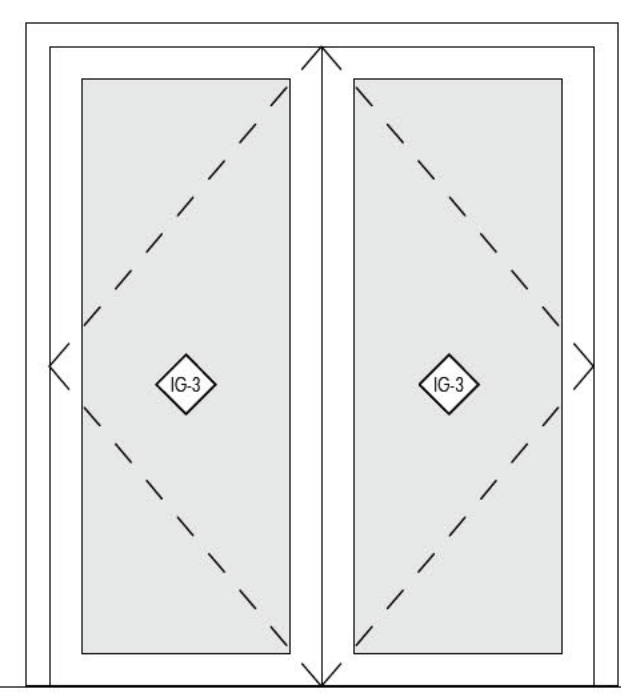

D-5

3 DOOR ELEVATIONS

ADDITION & REMODEL
BRIGGS BUILDING
333 W 1ST AVE ALBANY OR. 97321

REVISIONS:
1 4/10/2025 Rear Elevation

SHEET:
A6.01
SCHEDULES

PROJECT # 2024-014
DATE: 3/4/2025



Knox Construction Briggs Budget

CUSTOMER	Heart of the Valley Property, LLC
PROJECT NAME	Briggs building
TOTAL BASE PRICE	\$777,335.08
TOTAL PRICE AFTER MARK-UP	\$847,045.98
MATERIAL BASE PRICE	\$647,084.08
MATERIAL M/U PRICE	\$711,792.48

CUSTOMER SUMMARY

LABOR BASE PRICE	\$130,251.00
LABOR M/U PRICE	\$135,253.50

0.0 PRE-CONSTRUCTION	MATERIAL PRICING			LABOR PRICING			GRAND TOTAL
	BASE	M/U	TOTAL	BASE	M/U	TOTAL	
0.1 - 0.4							
0.1 PLANS	\$ -		\$ -	\$ -		\$ -	\$ -
0.2 ENGINEERING	\$ -		\$ -	\$ -		\$ -	\$ -
0.3 PERMITS	\$ -		\$ -	\$ -		\$ -	\$ -
0.4 ESTIMATING	\$ -		\$ -	\$ -		\$ -	\$ -
	\$ -		\$ -	\$ -		\$ -	\$ -

1.0 GENERAL CONDITIONS	MATERIAL PRICING			LABOR PRICING			GRAND TOTAL
	BASE	M/U	TOTAL	BASE	M/U	TOTAL	
1.1 - 1.5							
1.1 GENERAL CONDITIONS	\$ 0		\$ 0	\$ -		\$ -	\$ 0
1.2 TEMPORARY SERVICES	\$ 2,450	10%	\$ 2,695	\$ -		\$ -	\$ 2,695
1.3 PROJECT MANAGEMENT	\$ -		\$ -	\$ 39,900		\$ 39,900	\$ 39,900
1.4 EQUIPMENT RENTAL	\$ 27,500	10%	\$ 30,250	\$ -		\$ -	\$ 30,250
1.5 FINAL CLEANING	\$ -		\$ -	\$ -		\$ -	\$ -
	\$ 29,950		\$ 32,945	\$ 39,900		\$ 39,900	\$ 72,845

2.0 SITE WORK	MATERIAL PRICING			LABOR PRICING			GRAND TOTAL
	BASE	M/U	TOTAL	BASE	M/U	TOTAL	
2.1 - 2.4							
2.1 SEPTIC SYSTEM	\$ -		\$ -	\$ -		\$ -	\$ -
2.2 EXCAVATION	\$ 6,000	10%	\$ 6,600	\$ -		\$ -	\$ 6,600
2.3 UTILITIES	\$ -		\$ -	\$ -		\$ -	\$ -
2.4 LANDSCAPING	\$ -		\$ -	\$ -		\$ -	\$ -
	\$ 6,000		\$ 6,600	\$ -		\$ -	\$ 6,600

3.0 CONCRETE	MATERIAL PRICING			LABOR PRICING			GRAND TOTAL
	BASE	M/U	TOTAL	BASE	M/U	TOTAL	
3.1 - 3.3							
3.1 FOUNDATION	\$ 16,880	10%	\$ 18,568	\$ 21,918		\$ 21,918	\$ 40,486
3.2 INTERIOR FLATWORK	\$ -		\$ -	\$ -		\$ -	\$ -
3.3 EXTERIOR FLATWORK	\$ 3,000	10%	\$ 3,300	\$ -		\$ -	\$ 3,300
	\$ 19,880		\$ 21,868	\$ 21,918		\$ 21,918	\$ 43,786

4.0 FRAMING	MATERIAL PRICING			LABOR PRICING			GRAND TOTAL
	BASE	M/U	TOTAL	BASE	M/U	TOTAL	
4.1 - 4.4							
4.1 FRAMING	\$ 39,000	10%	\$ 42,900	\$ 50,025	10%	\$ 55,028	\$ 97,928
4.2 TRUSSES	\$ -		\$ -	\$ -		\$ -	\$ -
4.3 FASTENERS	\$ 1,700	10%	\$ 1,870	\$ -		\$ -	\$ 1,870

4.4 INSULATION	\$ 11,950	10%	\$ 13,145	\$ -		\$ -	\$ 13,145
	\$ 52,650		\$ 57,915	\$ 50,025		\$ 55,028	\$ 112,943

5.0 EXTERIOR FINISH	MATERIAL PRICING			LABOR PRICING			GRAND
5.1 - 5.7	BASE	M/U	TOTAL	BASE	M/U	TOTAL	TOTAL
5.1 SIDING & TRIM	\$ 48,355	10%	\$ 53,191	\$ -		\$ -	\$ 53,191
5.2 ROOFING	\$ 46,170	10%	\$ 50,787	\$ -		\$ -	\$ 50,787
5.3 PAINT	\$ 8,000	10%	\$ 8,800	\$ -		\$ -	\$ 8,800
5.4 SPECIALTIES	\$ -		\$ -	\$ -		\$ -	\$ -
5.5 SKYLIGHTS	\$ 3,200	10%	\$ 3,520	\$ -		\$ -	\$ 3,520
5.6 MASONRY	\$ 48,972	10%	\$ 53,869	\$ -		\$ -	\$ 53,869
5.7 GUTTERS	\$ 600	10%	\$ 660	\$ -		\$ -	\$ 660
	\$ 155,297		\$ 170,827	\$ -		\$ -	\$ 170,827

6.0 EXTERIOR DOORS & WINDOWS	MATERIAL PRICING			LABOR PRICING			GRAND
	BASE	M/U	TOTAL	BASE	M/U	TOTAL	TOTAL
6.0 EXTERIOR DOORS & WINDOWS	\$ 41,660	10%	\$ 45,826	\$ -		\$ -	\$ 45,826
	\$ 41,660		\$ 45,826	\$ -		\$ -	\$ 45,826

7.0 INTERIOR FINISH	MATERIAL PRICING			LABOR PRICING			GRAND
7.1 - 7.10	BASE	M/U	TOTAL	BASE	M/U	TOTAL	TOTAL
7.1 DRYWALL	\$ 66,500	10%	\$ 73,150	\$ -		\$ -	\$ 73,150
7.2 PAINT	\$ 24,000	10%	\$ 26,400	\$ -		\$ -	\$ 26,400
7.3 TILE	\$ -		\$ -	\$ -		\$ -	\$ -
7.4 FLOORING	\$ 44,200	10%	\$ 48,620	\$ -		\$ -	\$ 48,620
7.5 CABINETS	\$ 38,690	10%	\$ 42,559	\$ -		\$ -	\$ 42,559
7.6 COUNTERTOPS	\$ 14,555	10%	\$ 16,011	\$ -		\$ -	\$ 16,011
7.7 STAIRWAY	\$ -		\$ -	\$ -		\$ -	\$ -
7.8 FINISH CARPENTRY	\$ -		\$ -	\$ 18,408		\$ 18,408	\$ 18,408
7.9 SPECIALTIES	\$ -		\$ -	\$ -		\$ -	\$ -
7.10 WINDOW COVERINGS	\$ -		\$ -	\$ -		\$ -	\$ -
	\$ 187,945		\$ 206,740	\$ 18,408		\$ 18,408	\$ 225,148

8.0 APPLIANCES	MATERIAL PRICING			LABOR PRICING			GRAND
	BASE	M/U	TOTAL	BASE	M/U	TOTAL	TOTAL
8.0 APPLIANCES	\$ -		\$ -	\$ -		\$ -	\$ -
	\$ -		\$ -	\$ -		\$ -	\$ -

9.0 PLUMBING	MATERIAL PRICING			LABOR PRICING			GRAND
9.1 - 9.2	BASE	M/U	TOTAL	BASE	M/U	TOTAL	TOTAL
9.1 PLUMBING	\$ 68,000	10%	\$ 74,800	\$ -		\$ -	\$ 74,800
9.2 BATH ACCESSORIES	\$ -		\$ -	\$ -		\$ -	\$ -
	\$ 68,000		\$ 74,800	\$ -		\$ -	\$ 74,800

10.0 HVAC	MATERIAL PRICING			LABOR PRICING			GRAND
	BASE	M/U	TOTAL	BASE	M/U	TOTAL	TOTAL
10.0 HVAC	\$ 85,702	10%	\$ 94,272	\$ -		\$ -	\$ 94,272
	\$ 85,702		\$ 94,272	\$ -		\$ -	\$ 94,272

11.0 ELECTRICAL	MATERIAL PRICING			LABOR PRICING			GRAND TOTAL
	BASE	M/U	TOTAL	BASE	M/U	TOTAL	
11.1 - 11.4							
11.1 ELECTRICAL	\$ -		\$ -	\$ -		\$ -	\$ -
11.2 LOW VOLTAGE	\$ -		\$ -	\$ -		\$ -	\$ -
11.3 SECURITY	\$ -		\$ -	\$ -		\$ -	\$ -
11.4 LIGHTING FIXTURES	\$ -		\$ -	\$ -		\$ -	\$ -
	\$ -		\$ -	\$ -		\$ -	\$ -

12.0 MISCELLANEOUS	MATERIAL PRICING			LABOR PRICING			GRAND TOTAL
	BASE	M/U	TOTAL	BASE	M/U	TOTAL	
12.0 MISCELLANEOUS	\$ -		\$ -	\$ -		\$ -	\$ -
	\$ -		\$ -	\$ -		\$ -	\$ -



ELECTRICAL ENGINEERING FIRE PROTECTION HVAC MAINTENANCE PLUMBING UTILITY SUBMETERING

Solutions for a streamlined project

JET INDUSTRIES, INC.
PROPOSAL

March 24th, 2026

Knox Construction, Inc

Attn: Duane Knox



RE: Briggs Building Addition & Remodel – 333 W 21st Ave, Albany, OR 97321

Dear Duane,

Thank you for the opportunity to offer our services. Included in this package you will find a proposal for the Fire Sprinkler scope for this project.

DESCRIPTION OF PROJECT

Remodel and construction of an addition to a residential building.

PROJECT SCHEDULE

We assume that the project start date is within one month of this proposal and will be completed within 12 months after the start date.

Our proposal is based on construction drawings dated 9/2/25. The following are some additional comments and assumptions:

1. Standard wage rates apply.
2. Applicable local taxes including Oregon CAT Tax
3. In addition to our scope of work, please review the General Clarifications, General Exclusions, and Terms and Conditions sections listed at the bottom of this proposal.

Please do not hesitate to call if we can be of further assistance. We look forward to working with you on this project.

Sincerely,

Oliver W. Raab PE

Sr. Vice President





ELECTRICAL ENGINEERING FIRE PROTECTION HVAC MAINTENANCE PLUMBING UTILITY SUBMETERING

Solutions for a streamlined project

PRICING & SCOPES OF WORK

	HVAC	FIRE SPRINKLER	ELECTRICAL	PLUMBING
CONSTRUCTION PRICE SUB TOTAL	-	\$43,705.00	-	-

FIRE SPRINKLER

Provide and install wet Fire Sprinkler system:

All work will be performed in accordance with the standards of the National Fire Protection Association, and subject to the acceptance and inspection of the local fire marshal.

System type: NFPA 13

1. Interior Work

- a. Light and Ordinary hazard densities
- b. Professional engineer’s stamp
- c. All required hangers and earthquake braces
- d. Systems tests, permits, and associated fees
- e. Electric bell (wiring and installation by others)
- f. Water flow indicators (wiring by others)
- g. Control valve with tamper switches (wiring by others)
- h. ½” or 17/32” standard pendent/ upright sprinklers
- i. ½” semi-recessed pendent sprinklers
- j. ½” semi-recessed white residential pendent sprinklers
- k. Two-piece white canopy
- l. Dry horizontal sidewall sprinklers
- m. Flexible fire sprinkler drops at dropped ceiling areas (excludes cutting and or setting of ceiling tile)
- n. Fire department connection located on the building
- o. Double detector check valve assembly
- p. Floor control valves
- q. Fire stopping of fire sprinkler penetration of rated walls and floors
- r. CPVC to be used where allowed by NFPA code and/or listing
- s. Steel piping to be used where required per NFPA code and/or specifications

2. Exterior Work

- a. Excluded; Point of connection ±6” above finished floor

3. Clarifications

- a. Our bid is per bidder design or fire sprinkler plans and specifications only
- b. It is the owner’s responsibility to provide adequate heat (40 degrees minimum) in all areas protected by a wet pipe sprinkler system
- c. Structure is sufficient to support the installation of the sprinkler system and seismic attachments



ELECTRICAL ENGINEERING FIRE PROTECTION HVAC MAINTENANCE PLUMBING UTILITY SUBMETERING

Solutions for a streamlined project

- d. The water flow information to be provided to Jet Industries and is assumed accurate; Jet Industries is not responsible for discrepancies
 - e. Custom coloring of sprinkler head trim rings and/or cover plates to match owners painting schedule will incur additional cost and is not included in this proposal. The cost to provide custom colors on the trim rings and/or cover plates is \$500.00 per color and \$6.00 per trim ring or cover plate. Standard colors available upon request.
 - f. System design and hydraulic calculations will be based on available water flow information: Not available at time of bid. If the municipal water supply is not sufficient or unavailable, a fire pump and/or tank may be required to supply the sprinkler system.
4. Exclusions:
- a. Electrical wiring of any kind
 - b. Central monitoring of sprinkler system(s)
 - c. Fire alarm system
 - d. Connection to City main or final connection to onsite main
 - e. Underground piping other than that listed in exterior work
 - f. Fire hydrant
 - g. Draft curtains and/or draft stops, if required
 - h. Remote fire department connection
 - i. FDC Knox Caps and/or Knox boxes.
 - j. Fire pump, if required
 - k. Standpipes
 - l. Owners' insurance carrier approval and additional requirements, i.e.: FM Global standards
 - m. Additional cost due to special inspections and third-party inspections
 - n. Electric bells for each tenant space, includes only one outside bell
 - o. Fire extinguishers/cabinets, and special fire suppression systems, i.e. Hood suppression, FM200



ELECTRICAL ENGINEERING FIRE PROTECTION HVAC MAINTENANCE PLUMBING UTILITY SUBMETERING

Solutions for a streamlined project

POINTS OF CONTACT

Table with 4 columns of contact information for Jacob Eldredge, Wil Olson, Don Olheiser, Clint Olheiser, Mike Smith, Tom Marshall, Mark Boesch, and Bear Korsness.

ADDITIONAL WORK HOURLY RATE SCHEDULE:

Table listing hourly rates for various roles: Laborer (\$85/HR), Journeyman (\$115/HR), Superintendent (\$136/HR), Administrative (\$82/HR), Project Manager (\$147/HR), Design Engineer (\$175/HR), and Principal (\$225/HR).

Our overhead rate is 15% and our profit rate is 10%, which are in addition to our labor rates (see above), subcontractor costs, and materials costs.

GENERAL CLARIFICATIONS (ALSO SEE DIVISION SPECIFIC CLARIFICATIONS ABOVE)

- 7 numbered list items providing general clarifications regarding systems, drawings, shop drawings, price changes, material volatility, pre-purchase, and change orders.

*Solutions for a streamlined project*

8. Work areas will be fully accessible during established work hours. All work to be performed during day shifts as required (night shifts, double shifts, and/or overtime are not included).
9. Traditional stairways and handrails shall be installed by the general contractor per OSHA standards and regulations during the construction phase. Roof access is to be provided by the General Contractor. Subcontractor will not use extension ladders to access upper floors.
10. Subcontractor will not work in more than two areas at the same time while on site.
11. Any rock or stone which exceeds 12 inches in diameter, rock that requires blasting, chipping, or other method beyond regular track hoe removal will be removed at an additional cost to the Owner/General Contractor on a time and material basis. The general contractor will be notified before any such work takes place.
12. Daily cleanup services will be provided for our work scope; however, if at any time the General Contractor feels that we have not done so, we require a written notice of the incident. Jet Industries reserves the right to remedy the situation within 24 hours after receiving notice. We will not be responsible for cleanup back-charges at the conclusion of the project. Our intent is to address this issue immediately to avoid conflicts at the end of the job.
13. General Contractor must notify us within 24 hours of an incident of trade damage that affects our work.

GENERAL EXCLUSIONS (ALSO SEE DIVISION SPECIFIC EXCLUSIONS ABOVE)

1. Prevailing or BOLI wage rates and premium wage rates.
2. Stamped engineered drawings by registered professional engineer for Mechanical, Plumbing, and/or Electrical scopes (unless stated otherwise above).
3. Structural engineering calculations for equipment loads and structural modifications to structural systems. We assume the structure is adequate to support our systems.
4. Sales, Use, State Revenue, County, and City taxes, except as noted above.
5. Permits and plan review fees (unless stated otherwise above).
6. Payment and performance bond.
7. Fire caulking (unless stated otherwise above).
8. Excavation, trenching, and backfilling (unless stated otherwise above).
9. Radon piping and systems (unless stated otherwise above).
10. Concrete housekeeping pads (unless stated otherwise above).
11. Boiler and chiller systems (unless stated otherwise above).
12. Temporary heat/cooling, water, sewer, and power (unless stated otherwise above).
13. BIM coordination (unless stated otherwise above).
14. Demolition of any kind (unless stated otherwise above).
15. Equipment other than noted above.
16. Insulation, tenting, and/or heat tracing of piping or equipment (unless stated otherwise above).
17. Hauling, dumping, and storage of construction debris.
18. Asbestos, lead, and hazardous material containment and/or mitigation.
19. Insurance for projects that are covered by a "Wrap Policy," "OCIP," or "Condominiums."
20. Systems development charges and utility connection fees.
21. Our proposal and quoted price are based on the site conditions during our visit being the same when the above work is performed, unless otherwise noted.

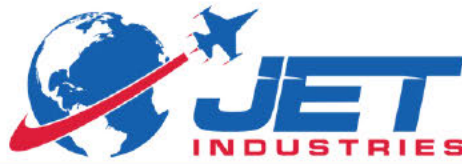

ELECTRICAL ENGINEERING FIRE PROTECTION HVAC MAINTENANCE PLUMBING UTILITY SUBMETERING

Solutions for a streamlined project

- 22. Cutting and/or patching of existing finishes to complete scope of work, including ceiling and sheetrock work.
- 23. Weather sealing of any penetrations through the building envelope or water membrane.
- 24. Allowance for any hidden conditions, except as noted above.
- 25. Correction of unsafe and/or unsanitary working conditions. General Contractor to provide and maintain all OSHA-required safety standards.
- 26. Supply and installation of any appliances, including refrigerator ice makers, washing machine supply tubes, and final connections.
- 27. Jet Industries excludes providing and installing any and all products used for sound isolation, sound vibration, and acoustics including acoustical wrapping, felt pads, sound deadening pads, vinyl and neoprene wrapping, Holdrite sound deadening products or similar, and any products related to the above-mentioned installation. Jet will install water hammer arrestors as per code.
- 28. Painting and/or coating of any kind including the removal of markings or preparation of materials for any painting/coating.

LICENSES

ARIZONA
 HVAC: ROC 129789
 Electrical: ROC 262009
 Plumbing: ROC 262010
 Fire Sprinkler: ROC 351962-C16

CALIFORNIA CSLB: 475267
 IDAHO: RCE-21964
 OREGON CCB: 3944
 TEXAS DLR: TACL B15486E
 WASHINGTON L&I: JETINII903D5

ACCEPTANCE AND WARRANTY PROVISION

By signing below, the undersigned agrees to be bound by the terms and conditions attached, the pricing and scope identified above, including but not limited to the following:

- 1. The disclaimer of all warranties except those expressly stated in this agreement.
- 2. Any manufacturer’s warranty shall be passed through directly from the manufacturer to the purchaser.
- 3. The limitation on punitive and consequential damages arising under this agreement.
- 4. The prohibition on oral modification of this agreement.

Prime Contractor/ Purchaser:

Date:



Solutions for a streamlined project

TERMS AND CONDITIONS

1. **Quoted Price:** Quoted prices are in effect for 30 days from quote, unless otherwise specified on the face of hereof. If total cost of the project varies from the agreed upon schedule, Jet Industries, Inc. (hereinafter referred to as "JET") may amend the total quotation to reflect changed costs applicable to the project.
2. **Additional Charges:** Reasonable additional charges will be assessed by JET for any extra work performed, including any repairs related to loss or damage to any goods before or after installation.
3. **Standard Terms of Purchase:** The standard terms of purchase are as follows:
 - Progress payments are due by the 10th of the month following services rendered in the prior month until the balance is paid in full according to terms set forth on face of this agreement.
4. **Title to Goods:** Title to the goods, personal property, and merchandise described on the face of this agreement ("goods"), and title to all goods furnished or to be supplied under the order shall remain in JET, until all amounts owing hereunder are paid. The goods shall not by reason of its installation or annexation in or to any real property or improvement thereon be construed as real property or part of an improvement while any consideration remains unpaid, and said described goods shall retain its personal character and not become a fixture and may be repossessed by JET, if not completely paid for under the terms of this agreement.
5. **Security:** As security for the timely performance of all of PURCHASER's obligations under this agreement, including payment in full of the purchase price indicated on the face of this agreement, JET retains and PURCHASER grants to JET, until the purchase price is paid in full, a security interest in the goods described on the face of this agreement. PURCHASER grants JET authority to file a UCC financing statement or fixture filing perfecting JET's interest in the goods.
6. **Delinquency Charges:** A delinquency charge will be paid by the PURCHASER at the rate of 1.5% per month or fraction thereof in which any charge or installment is overdue. The minimum delinquency charge on balances under \$17.00 is \$.50.
7. **Default:** The failure of the PURCHASER to pay the purchase price, or any installment when due shall cause the PURCHASER to be in default and shall operate at the option of JET to make the full purchase price immediately due and payable. JET may thereupon repossess all such goods, and remove same from the PURCHASER'S premises. At the request of JET, the purchaser will assemble the goods listed or referenced on the face of this agreement and make them available to JET, at a location designated by JET.
8. **Effect of Repossession:** In the event of JET's repossession of any good, as above set forth, the PURCHASER hereby appoints JET, or any representative thereof, PURCHASER's agent and attorney in fact to sell said personal property at public or private sale at any time or place, without notice, or having such personal property at the place of sale. From the proceeds of any such sale there will be first paid the expense of repossessing, holding, removing, repairing, and selling the personal property, including reasonable attorney's fees and legal expenses incurred in connection therewith; the balance thereof shall be applied to the payment of the balance due upon this purchase with the surplus, if any, to be paid to the PURCHASER. PURCHASER agrees to pay any deficiency remaining after said sale (if any), subject to limitations under the State in which the work is performed.
9. **Breach Not a Defense to Payment:** Assertion of a breach of this contract is not a defense to payment of any amount due herein.
10. **Attorney Fees:** If any amount due under this contract is placed in the hands of an attorney for collection, PURCHASER promises and agrees to pay JET reasonable attorney's fees and collections costs, even though no suit or action is filed hereon; if a suit or action is filed, the losing party shall pay to the prevailing party the costs above described, and the prevailing party's reasonable attorney and legal assistant fees as may be awarded by the Court, including awards on any appeals therefrom. In the event that PURCHASER files for protection under the U.S. Bankruptcy Act during the term of the contract, Purchaser shall pay to JET all of JET's attorney and legal assistant fees and costs incurred to protect JET's interest in the goods during the term of bankruptcy, whether or not JET is the prevailing party.
11. **Document Ownership:** All reports, plans, designs, specifications, field data and notes, and other documents including all documents on electronic media produced by JET remain the property of JET and shall not be used for any purposes other than for the construction of the project by JET, its subcontractors, or agents. PURCHASER may make and retain copies for information and reference in connection with the use and occupancy of the PROJECT; however, such documents are not intended or represented to be suitable for reuse by any person for extension of the Project or for any other project. PURCHASER agrees, to the fullest extent permitted by law, to indemnify, defend, and hold JET harmless from any claim, cause of action, liability or cost (including reasonable attorney's fees and defense costs of trial, arbitration, or appeal) arising out or allegedly arising out of any unauthorized reuse or modification of the documents by PURCHASER or any person or entity that acquires or obtains the documents from or through PURCHASER without written authorization from JET.
12. **Standard of Care:** The services provided by JET under this agreement will be performed in a good and workmanlike manner.



ELECTRICAL ENGINEERING FIRE PROTECTION HVAC MAINTENANCE PLUMBING UTILITY SUBMETERING

Solutions for a streamlined project

13. **Merger Provision:** The sales personnel of the JET are not authorized to make warranties about the goods described in this contract. JET's employees' ORAL STATEMENTS DO NOT CONSTITUTE WARRANTIES, shall not be relied upon by the PURCHASER, and are not part of the contract for sale. The entire contract is embodied in this writing and NO OTHER WARRANTIES are given beyond those set forth in this written contract. This writing constitutes the final expression of the parties' agreement, and it is a complete and exclusive statement of the terms of that agreement.
14. **Limited Warranty:** JET warrants that any goods to be delivered will be of the kind and quality described in the order or contract, and installation of such goods will be free of defects in workmanship for one year after the date of installation. JET is selling the goods on an "as is" basis. The risk of loss regarding any good under this agreement will transfer from JET to PURCHASER on the initial delivery date. If the good proves defective after purchase and delivery, the PURCHASER and not JET assumes the entire cost of all necessary servicing or repair, subject to any warranty offered by the manufacturer of the goods which shall pass through directly from the manufacturer to PURCHASER.
Should any failure to conform to this warranty appear within one year of the initial date of delivery, JET will, upon notification thereof and substantiation that the goods have been stored, maintained and operated in accordance with JET's recommendations and standard industry practice, correct such defects by suitable repair or replacement at its own expense, if the defect is a result of JET's installation of the goods.
THIS WARRANTY IS EXCLUSIVE AND IS IN LIEU OF ANY IMPLIED WARRANTY OF MERCHANTABILITY, FITNESS FOR A PARTICULAR PURPOSE OR OTHER WARRANTY OF QUALITY, WHETHER EXPRESS OR IMPLIED, EXCEPT THE WARRANTY OF TITLE AND AGAINST PATENT INFRINGEMENT. Correction of nonconformities, in the manner and for the period of time provided above, shall constitute fulfillment of all liabilities of JET to PURCHASER with respect to the goods, whether based on contract, negligence, strict tort or otherwise.
15. **Third Party Beneficiaries of Warranty:** Any warranty available to PURCHASER under this agreement extends to any natural person who is in the family or household of PURCHASER or who is a guest in PURCHASER's home if it is reasonable to expect that such person may use, consume, or be affected by the goods and who is injured in person by breach of the warranty. In no other circumstance does this warranty extend to any person without privity of contract. A subsequent purchaser of the goods shall not have any rights under this agreement not assigned to such person by PURCHASER.
16. **Limitation of Liability:** JET shall not under any circumstances be liable for special, punitive, or consequential damages such as, but not limited to, damage or loss of other property or equipment, loss of profits or revenue, cost of capital, cost of purchased or replacement goods, or claims of customers of PURCHASER. The remedies of PURCHASER set forth herein are exclusive, and the liability of JET with respect to any contract, or anything done in connection therewith such as the performance or breach thereof, or from the manufacture, sale, delivery, resale, installation, or use of any goods covered by or furnished under this contract whether arising out of contract, negligence, strict tort, or under any warranty, or otherwise, shall not, except as expressly provided herein, exceed the price of the goods and services upon which such liability is based. PURCHASER hereby agrees and acknowledges that PURCHASER has a duty to mitigate and help limit potential damages from water leaks arising from the installation work, goods, or services provided by JET. PURCHASER shall visually inspect all rooms and premises where installation work, goods, or services were provided by JET at least once every 14 days for water leaks and promptly inform JET of any such water leaks. JET shall not be liable for any damages associated with its installation work, goods, or services delivered to PURCHASER arising out of water leaks which continue for more than 14 days prior to being reported to JET.
17. **Time for Claim:** Any legal claim that may arise under this contract, whether based in contract, negligence, tort, or under any warranty, shall be barred unless it is brought within one year after the initial date of delivery except as follows. JET reserves the right to make a claim at anytime to the Owner, Contractor, or others, for payment of services rendered.
18. **Fees:** PURCHASER shall pay the cost of permit and inspection fees, and other charges not specifically covered by the terms of this agreement. Any such fees paid by JET on behalf of PURCHASER shall be reimbursed, along with other reimbursable expenses, as invoiced.
19. **PURCHASER Information:** PURCHASER shall provide all criteria and full information as to PURCHASER's requirements for the Project, designate a person to act with authority on PURCHASER's behalf with respect to all aspects of the Project, examine JET's submissions and respond promptly to JET, and give prompt written notice to JET whenever PURCHASER observes or otherwise becomes aware of any defect in the work. JET has a right to rely on the accuracy and completeness of information provided by PURCHASER.
20. **Subrogation:** JET and PURCHASER mutually waive all rights against each other for property damage or loss of use of property to the extent covered by insurance and shall have their policies endorsed to waive subrogation rights of their insurer so as to be



ELECTRICAL ENGINEERING FIRE PROTECTION HVAC MAINTENANCE PLUMBING UTILITY SUBMETERING

Solutions for a streamlined project

binding upon each of their respective property, liability, worker's compensation, automobile, or equipment insurer respecting any subrogation rights which such insurers may possess by virtue of payment of claim or loss.

21. **Limitation of Claims:** JET and its insurers shall not be liable for (a) any injury or damage arising from a prior occurrence or progressively deteriorating injury or damage under general liability, (b) condominiums, (c) apartments which are converted to condominiums at any time, (d) single family residential projects, (e) EIFS, (f) subsidence, (g) notice of cancellation requirements which exceed thirty (30) days; and (h) "named insured" requirements.
22. **Conversion of Apartments to Condominiums:** PURCHASER will indemnify, reimburse, and hold harmless JET from any bodily injury and property damage losses and expenses, regardless of the nature due to the conversion of apartments to condominiums.
23. **Indemnification:** The work performed by JET shall be at its exclusive risk. To the fullest extent permitted by law, JET will defend, indemnify and hold harmless all indemnified parties from any and all claims for bodily injury and property damage (other than damage to the work itself), including the loss of use of property resulting therefrom, which arise or are in any way connected with the work performed, materials furnished or services provided by JET, JET's subcontractors or anyone employed directly or indirectly by any of them under this agreement. Indemnified parties include the contractor, Owner (if different from Contractor), affiliated companies, partners, joint ventures, representatives, members, designees, officers, directors, shareholders, employees, agents, successors and their assigns. Claims include any and all claims for bodily injury, death, or damage to property, demands, damages, actions, causes of action, suits, losses, judgments, obligations, and any liabilities, costs, and expenses (including but not limited to investigative and repair costs, attorneys' fees, and consultants' fees). JET is not obligated to indemnify and defend contractor or Owner for claims due to the sole negligence or willful misconduct of indemnified parties. Any obligations assumed pursuant to this agreement will not be construed to negate, abridge, or reduce other rights or obligations of indemnity, which otherwise exist as to a party or person described in this agreement. JET's indemnification and defense obligations under this contract extend to claims occurring after this agreement is terminated as well as while it is in force and continue until it is finally adjudicated that any and all actions against the indemnified parties for such matters which are indemnified hereunder are fully and finally barred by applicable laws.

Briggs Building Albany
Abbot Briggs Building
4/10/2025

333 1st Ave W

Prepared by:



Prepared For:

James Abbott
Heart of the Valley LLC.
1237 Northwest Scenic Drive
Albany, OR 97321

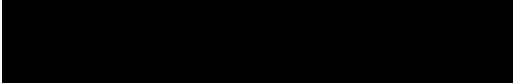

Prepared By:

Nick Carter

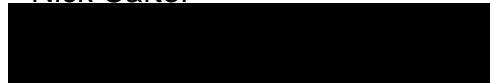

Office: 5412588510



FIND US ON THE WEB AT



Sold To
James Abbott Heart of the Valley LLC. 1237 Northwest Scenic Drive Albany, OR 97321

Site Location
Briggs Building Albany 333 1st Ave Albany, OR 97321

Salesperson	Quote Total	Quote Expiration	Terms
Nick Carter	\$97,988.78	5/10/2025	Net 30

Scope of Work:

Install Fire Sprinkler System in Briggs Building

Labor Materials and Equipment
 Design, Plans, Permit Submittal and Permit Fees
 Design NFPA 13R System for 2nd and 3rd Floors
 Design NFPA 13 Ordinary Hazard (Group 1) First Floor Retail Space (Design for Restaurant)
 NFPA 13R System will be Concealed Pipe and Fittings (Blazemaster CPVC)
 NFPA 13 Ordinary Hazard Group 1 will be exposed Piping utilizing Sidewall Fire Sprinklers in Larger Areas.
 Concealed Fire Sprinklers in Residential Spaces and First Floor Small Areas.
 Installation and Seismic per NFPA 13 Standards
 Fire Department Connection Front of Building per City of Albany Specs.
 Backflow located in Sidewalk in Vault with FDC Check
 Pipe under Floor to Riser Location CPVC Blazemaster
 Work to be done M-F 7am to 5pm (Odd shifts may require a Change Order for Labor Rates)
 Installation Designed and Installed to currently adopted NFPA 13 and Local Codes

Exclusions:

Any Electrical
 2" Water Main from City 10" Main
 Alarm System
 Permits Billed Separately at Cost
 Excavation
 Concrete or Sidewalk Replacement
 Sheetrock Repairs
 Painting

Notes:

Deposit: 50% deposit will be required before Design, parts, or work begins.
 Material cost changes more than 3% before deposit is received will require a change order.
 In the event of project cancellation, the customer will be responsible for any non-cancellable component orders, permit payments, completed engineering, and completed labor cost.
 Terms: Net 10

Quote Total: \$97,988.78

Terms & Conditions

Assignment and Delegation: CUSTOMER may not assign its rights or delegate its obligations under this Agreement, in whole or in part, without the prior written consent of PSIC. PSIC may assign its right to receive payments to a third party.

CUSTOMER shall be responsible for maintaining all liability and property insurance. No insurer or other third party will have any subrogation rights against PSIC.

Hazardous Materials: CUSTOMER represents and warrants that, except as otherwise disclosed in this in the areas where PSIC will undertake work or provide Services, there are no: (a) materials or substances classified as toxic or hazardous either (i) on or within the walls, floors, ceilings or other structural components or (ii) otherwise located in the work area, including asbestos or presumed asbestos-containing materials, formaldehyde, containers or pipelines containing petroleum products or hazardous substances, etc.; (b) situations subject to special precautions or equipment required by federal, state or local health or safety regulations; or (c) unsafe working conditions.

CUSTOMER SHALL INDEMNIFY AND HOLD PSIC HARMLESS FROM AND AGAINST ANY AND ALL CLAIMS AND COSTS OF WHATEVER NATURE, INCLUDING BUT NOT LIMITED TO, CONSULTANTS' AND ATTORNEYS' FEES, DAMAGES FOR BODILY INJURY AND PROPERTY DAMAGE, FINES, PENALTIES, CLEANUP COSTS AND COSTS ASSOCIATED WITH DELAY OR WORK STOPPAGE, THAT IN ANY WAY RESULTS FROM OR ARISES UNDER SUCH MATERIALS, SITUATIONS OR CONDITIONS, REGARDLESS OF WHETHER CUSTOMER HAS PRE-NOTIFIED PSIC. THIS INDEMNIFICATION SHALL SURVIVE TERMINATION OF THIS AGREEMENT FOR WHATEVER REASON.

Warranties and Limitation of Liability: PSIC will replace or repair any product PSIC provides or CUSTOMER procures under this Agreement that fails within the warranty period (Typically one-year) due to defective workmanship or materials. Only items covered under the manufacturer's terms and conditions are covered by PSIC. Warranty services will be performed during normal business hours (8:00AM-5:00PM, Monday-Friday, excluding holidays). Repair or replacement will be accomplished as determined by the product manufacturer. The building owner will provide free access to all equipment. Any requirements for lifts, ladders of 6' tall, and/or access hatches, etc. are excluded. Services requested to repair or replace items damaged by acts outside of the scope of warranty will be billable at PSIC current services rates.

The failure must not result from CUSTOMER's negligence; or from fire, lightning, water damage, or any other cause beyond PSIC control. This warranty applies to PSIC fabricated and outside-purchased products. The warranty effective date is the date of CUSTOMER acceptance of the product or the date CUSTOMER begins to receive beneficial use of the product, whichever comes first. THE WARRANTIES SET FORTH HEREIN ARE EXCLUSIVE, AND PSIC EXPRESSLY DISCLAIMS ALL OTHER WARRANTIES, WHETHER WRITTEN OR ORAL, IMPLIED OR STATUTORY, INCLUDING BUT NOT LIMITED TO, ANY WARRANTIES OF MERCHANTABILITY AND FITNESS FOR A PARTICULAR PURPOSE, WITH RESPECT TO THE SERVICES, EQUIPMENT, AND MATERIALS PROVIDED HEREUNDER. PSIC SHALL NOT BE LIABLE FOR ANY SPECIAL, INDIRECT, INCIDENTAL OR CONSEQUENTIAL DAMAGES ARISING FROM, OR RELATING TO, THIS LIMITED WARRANTY OR ITS BREACH.

PSIC shall not be liable for damages caused by delay or interruption in Services due to fire or flood; corrosive substances in the air or water supply that may enter or otherwise affect sprinkler piping and sprinkler systems including but not limited to biological growth, Calcium Carbonate Deposits and microbiologically influenced corrosion (MIC); strike, lockout, dispute with workmen, inability to obtain material or services, marine transportation issues, war, act of God or any other cause beyond PSIC reasonable control. Should any part of the system or any Equipment be damaged by fire, water, water leakage, freezing pipes, lightning, acts of God, third parties or any other cause beyond the control of PSIC, any repairs or replacement shall be paid for by CUSTOMER.

Indemnity and Limitation of Liability: PSIC agrees to indemnify and hold CUSTOMER and its agents and employees harmless from all claims for bodily injury and property damages to the extent such claims result from or arise under PSIC negligent actions or willful misconduct in its performance of the Services. PROVIDED, THAT NOTHING IN THIS ARTICLE SHALL BE CONSTRUED OR UNDERSTOOD TO ALTER THE LIMITATIONS OF LIABILITY CONTAINED IN THIS ARTICLE OR THE INDEMNIFICATION CONTAINED IN SECTION 4. IN NO EVENT SHALL PSIC BE LIABLE FOR ANY SPECIAL, INCIDENTAL, INDIRECT, SPECULATIVE, REMOTE, OR CONSEQUENTIAL DAMAGES ARISING FROM, RELATING TO, OR CONNECTED WITH THE SERVICES, EQUIPMENT, MATERIALS, OR ANY GOODS PROVIDED HEREUNDER. SUCH INDEMNITY OBLIGATION IS VALID ONLY TO THE EXTENT CUSTOMER GIVES PSIC REASONABLY PROMPT NOTICE IN WRITING OF ANY SUCH CLAIMS AND PERMITS PSIC, THROUGH COUNSEL OF ITS CHOICE, TO ANSWER THE CLAIMS AND DEFEND ANY RELATED SUIT.

The parties further agree that PSIC is not an insurer, that the Services purchased herein is designed only to reduce the risk of loss; that CUSTOMER chose the level and scope of services being provided by PSIC from a variety of service options; that PSIC will not be held liable for any loss, in tort or otherwise, which may arise from the failure of the system(s) and/or service(s) or any errors and omissions in the above

BECAUSE IT IS IMPOSSIBLE TO ASSESS ACTUAL DAMAGES ARISING FROM THE FAILURE OF A SYSTEM AND/OR SERVICE PROVIDED UNDER THIS AGREEMENT, THE PARTIES AGREE THAT IF ANY LIABILITY IS IMPOSED ON PSIC FOR DAMAGES OR PERSONAL INJURY TO EITHER CUSTOMER OR ANY THIRD PARTY, SUCH LIABILITY SHALL BE LIMITED TO AN AMOUNT NOT TO EXCEED THE AMOUNT OF THE CHARGE OF THIS AGREEMENT.

MISCELLANEOUS

Extent of Agreement: Except as and to the extent provided in the Contract, this Agreement represents the entire Agreement between CUSTOMER and PSIC for the services described herein and supersedes all prior negotiations, representations or Agreements between the Parties related to the Services described herein.

None of the provisions of this Agreement shall be modified, altered, changed or voided by any subsequent document unilaterally issued by CUSTOMER that relates to the subject matter of this Agreement. This Agreement may be amended only by written instrument signed by both Parties.

PSIC shall not be liable for any delay in producing, delivering, installing, or giving advice and technical assistance for any of the equipment or software covered hereunder if such delay shall be due to one or more of the following causes fire, strike, lockout, dispute with workmen, flood, lightning, accident, delay in transportation, shortage of fuel, inability to obtain material, war, embargo, demand or requirement of the United States or any governmental or war activity, or any other cause whatsoever beyond the reasonable control of PSIC. In addition, PSIC shall not be liable for any delays caused by failure of CUSTOMER, or its agent, or any person or entity not a party hereto, to perform any of its obligations in a timely manner.

EXCLUSIONS

Any and all items not specifically outlined in the scope of the proposal are excluded. This exclusion covers (but is not limited to) sales tax, unforeseen items in the ground, HVAC and/or duct detection tie-ins, fire-stopping materials in raceway sleeves, programming of devices supplied by other companies, structural engineering, fire watch, drawings, permits, professional Engineer review and/or PE stamped drawings, sales tax, overtime, framing, patching, painting, millwork, stucco, texturing, or other finish repairs, system design, additional devices, repair, troubleshooting, or testing of existing wiring and devices, power for equipment supplied by others; changes directed by the Fire Marshal and or the Authority Having Jurisdiction beyond minimum code requirements or require addition of fire alarm devices, placement of fire alarm devices, or exclusion of fire alarm devices, and any other items not specifically mentioned in this proposal.

DEPOSIT

Any proposal exceeding \$10,000 requires a mobilization deposit of no less than 15% and proposals in excess of \$20,000 require 25%. Material will not be ordered and work will not begin until the deposit is received. Any change in material costs exceeding 3% before deposit is received will require a change order to cover additional costs.

ACCESS & NOTIFICATION

All work is to be completed during normal business hours (Mon-Fri/7am-4pm). Customer is responsible for providing PSIC technicians unrestricted access during scope of work. Fire alarm notification may be activated during scope of work. If return trips are required to complete the scope of work due to access or denied notification further charges may apply.

DISPUTE RESOLUTION

This Agreement shall be deemed to be made in Multnomah County, Oregon, regardless of the location of any office or representative of CUSTOMER, or the location of the equipment, or the place of signing by any party. This Agreement will be governed by Oregon law. The venue for any claim arising under this Agreement shall be in Multnomah County, Oregon.

In the event of a dispute regarding the interpretation or enforcement of the Agreement which results in litigation, the prevailing party shall have its attorney's fees and costs paid by the losing party.

Insurance: Our proposed pricing is inclusive of our costs to perform the scope of services outlined in this proposal. There may be additional costs or fees incurred by Performance Systems due to specific insurance requirements presented by your Risk Management/Compliance team which may need to be shared by you.

Customer Approval:

Signature: _____

Date: _____

Name: _____
(Please Print)

Title: _____

Purchase
Order: _____

Billing
Contact: _____

Billing
Address: _____

This proposal and the attached pages shall become an Agreement upon signature below by CUSTOMER. No waiver or modification of any terms or conditions of this Agreement shall be binding on PSI unless made in writing and signed by an authorized representative of PSI.

Honoring Architectural Heritage with Interior Flooring Choices

Our new commercial tenant is interior designer Heather Van Eyk of Taylaire, Inc, DBA Budget Blinds of Albany and Corvallis. Bringing her design talent to the interior of the 1875 John Briggs building, she has been invaluable in directing authentic interior choices that honor the historic architecture of the building. This is her statement regarding the choice of flooring for the first floor retail space:

The intent behind the flooring selection is to honor and reinforce the historic character of this building while ensuring long-term durability and functionality. Given that the structure is over 100 years old, linoleum is a historically appropriate material that aligns with the period in which the building was originally constructed and occupied. Linoleum was widely used in both residential and commercial interiors during the late 19th and early 20th centuries due to its resilience, natural composition, and practical performance.

In addition to material authenticity, the proposed checkerboard layout reflects a classic design motif commonly found in historic interiors. This pattern not only enhances the visual character of the space but also contributes to a sense of timelessness that is consistent with the building's architectural heritage. The scale and layout of the pattern will be carefully considered to complement the proportions of the space and avoid overpowering original features.

This approach strikes a thoughtful balance between preservation and usability—maintaining historical integrity while providing a durable, low-maintenance flooring solution suitable for modern use. By selecting materials and patterns that are both historically grounded and enduring, the design aims to respect the building's past while supporting its continued relevance and function.

Warmest regards,

*Heather Van Eyk
Owner & Designer
Budget Blinds of Albany and Corvallis*



ESTIMATE #	208	ESTIMATE DATE	01/04/2026
P.O.#	#201		

BILL TO

HEART OF THE VALLEY PROPERTIES
 Jim Abbott
 Corina Abbott

SHIP TO

BRIGG BUILDING
 333 W 1ST AVE #201
 ALBANY OR 97321

HPDX.LLC

CCB# 254061
 Email :

QTY	DESCRIPTION	UNIT PRICE	AMOUNT
1	White Shaker Cabinet - Upper Cabinet	0.00	0.00
1	W3040 WALL CABINET DOUBLE DOOR	0.00	0.00
1	W2140 WALL CABINET SINGLE DOOR	0.00	0.00
1	W2140 WALL CABINET SINGLE DOOR	0.00	0.00
1	WBC2740 - 27"X40" WALL BLIND CORNER CABINET	0.00	0.00
1	W2740 WALL CABINET DOUBLE DOOR	0.00	0.00
1	W3021 - 30"(W)X21"(H) WALL CABINET DOUBLE DOOR	0.00	0.00
1	W2740 WALL CABINET DOUBLE DOOR	0.00	0.00
1	W3321 - 33"(W)X21"(H) WALL CABINET DOUBLE DOOR	0.00	0.00
1	GREY SHAKER CABINET - Base Cabinet	0.00	0.00
1	B30 - BASE CABINET Two DOOR WITH DRAWER	0.00	0.00
1	B30 - BASE CABINET Two DOOR WITH DRAWER	0.00	0.00
1	BBC39-42 - BASE BLIND CORNER CABINET WITH 1 DRAWER	0.00	0.00
1	SB36 - SINK BASE	0.00	0.00
1	B21 - BASE CABINET SINGEL DOOR WITH	0.00	0.00

DRAWER			
1	BBC39-42 - BASE BLIND CORNER CABINET WITH 1 DRAWER	0.00	0.00
1	DB27 - BASE CABINET WITH 3 DRAWERS	0.00	0.00
1	Grey Shaker Cabinet - Bathroom Vanity	0.00	0.00
1	VA3021 - 30"(W)X21"(D) VANITY SINK BASE CABINET DOUBLE DOOR	0.00	0.00
1	VAD3621(L) - 36"(W) 21"(D) VANITY SINK BASE CABINET W/ LEFT DRAWER BANK	0.00	0.00
1	Trims	0.00	0.00
1	Cabinet Trims including Toe Kick Scribe Molding Filler Finish Panel *Quarter Round - Provide Material Only	0.00	0.00
1	NO Quarter Round	0.00	0.00
1	NO Crown Molding	0.00	0.00
1	NO Hardware or Handle	0.00	0.00
17	Total Unit of Cabinets Material	0.00	0.00
1	TOTAL CABINET MATERIAL WITH ASSEMBLING CABINET Delivery to Job Site	5,350.00	5,350.00
1	CABINET INSTALLATION FEE	1,377.00	1,377.00

ESTIMATE TOTAL

\$6,727.00

TERMS & CONDITIONS

COLOR AND SHADE VARIATION ARE INHERENT CHARACTERISTIC OF ALL CABINET AND NATURAL STONE PRODUCTS.INSPECT ALL MATERIAL BEFORE INSTALLATION. NO RETURN ON SPECIAL ORDER INTENS, NON-STOCKED MATERIAL.All dimensions size designations given are subject to verification on job site and adjustment to fit job conditions.

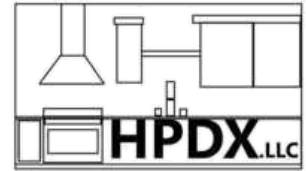

ESTIMATE #	209	ESTIMATE DATE	01/04/2026
P.O.#	#202		

BILL TO

HEART OF THE VALLEY PROPERTIES
 Jim Abbott
 Corina Abbott

SHIP TO

BRIGG BUILDING
 333 W 1ST AVE #202
 ALBANY OR 97321

HPDX.LLC

CCB# 254061

QTY	DESCRIPTION	UNIT PRICE	AMOUNT
1	White Shaker Cabinet - Upper Cabinet	0.00	0.00
1	W2140 WALL CABINET SINGLE DOOR	0.00	0.00
1	W2140 WALL CABINET SINGLE DOOR	0.00	0.00
1	W2440 WALL CABINET DOUBLE DOOR	0.00	0.00
1	WBC2740 - 27"X40" WALL BLIND CORNER CABINET	0.00	0.00
1	W3040 WALL CABINET DOUBLE DOOR	0.00	0.00
1	W3040 - 30"(W)X40"(H) WALL CABINET DOUBLE DOOR	0.00	0.00
1	W3040 WALL CABINET DOUBLE DOOR	0.00	0.00
1	WBC2740 - 27"X40" WALL BLIND CORNER CABINET	0.00	0.00
1	W3340 WALL CABINET DOUBLE DOOR	0.00	0.00
1	W3321 - 33"(W)X21"(H) WALL CABINET DOUBLE DOOR	0.00	0.00
1	GREY SHAKER CABINET - Base Cabinet	0.00	0.00
1	B21 - BASE CABINET SINGEL DOOR WITH DRAWER	0.00	0.00
1	SB36 - SINK BASE	0.00	0.00
1	B21 - BASE CABINET SINGEL DOOR WITH DRAWER	0.00	0.00

1	BBC39-42 - BASE BLIND CORNER CABINET WITH 1 DRAWER	0.00	0.00
1	B30 - BASE CABINET Two DOOR WITH DRAWER	0.00	0.00
2	BBC42-45 - BASE BLIND CORNER CABINET WITH 1 DRAWER	0.00	0.00
1	Grey Shaker Cabinet - Bathroom Vanity	0.00	0.00
1	VAD4821 - 48"(W)X21"(D) VANITY SINK BASE CABINET DOUBLE DOOR	0.00	0.00
1	Trims	0.00	0.00
1	Cabinet Trims including Toe Kick Scribe Molding Filler Finish Panel *Quarter Round - Provide Material Only	0.00	0.00
1	NO Quarter Round	0.00	0.00
1	NO Crown Molding	0.00	0.00
1	NO Hardware or Handle	0.00	0.00
17	Total Unit of Cabinets Material	0.00	0.00
1	TOTAL CABINET MATERIAL WITH ASSEMBLING CABINET Delivery to Job Site	5,250.00	5,250.00
1	CABINET INSTALLATION FEE	1,300.00	1,300.00

ESTIMATE TOTAL

\$6,550.00

TERMS & CONDITIONS

COLOR AND SHADE VARIATION ARE INHERENT CHARACTERISTIC OF ALL CABINET AND NATURAL STONE PRODUCTS.INSPECT ALL MATERIAL BEFORE INSTALLATION. NO RETURN ON SPECIAL ORDER INTENS, NON-STOCKED MATERIAL.All dimensions size designations given are subject to verification on job site and adjustment to fit job conditions.



ESTIMATE #	210	ESTIMATE DATE	01/04/2026
P.O.#	#301		

BILL TO

HEART OF THE VALLEY PROPERTIES
Jim Abbott

SHIP TO

BRIGG BUILDING
333 W 1ST AVE #301
ALBANY OR 97321

HPDX.LLC

CCB# 254061
Email :

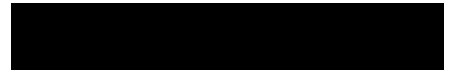

QTY	DESCRIPTION	UNIT PRICE	AMOUNT
1	White Shaker Cabinet - Upper Cabinet	0.00	0.00
1	W3321 - 33"(W)X21"(H) WALL CABINET DOUBLE DOOR	0.00	0.00
1	W3021 - 30"(W)X21"(H) WALL CABINET DOUBLE DOOR	0.00	0.00
1	W2440 WALL CABINET DOUBLE DOOR	0.00	0.00
1	WBC2740 - 27"X40" WALL BLIND CORNER CABINET	0.00	0.00
1	W3340 WALL CABINET DOUBLE DOOR	0.00	0.00
1	GREY SHAKER CABINET - Base Cabinet	0.00	0.00
1	BBC39-42 - BASE BLIND CORNER CABINET WITH 1 DRAWER	0.00	0.00
1	SB30 - SINK BASE	0.00	0.00
1	B09 - BASE CABINET SINGEL DOOR WITH DRAWER	0.00	0.00
1	Grey Shaker Cabinet - Bathroom Vanity	0.00	0.00
1	VA3021 - 30"(W)X21"(D) VANITY SINK BASE CABINET DOUBLE DOOR	0.00	0.00
1	Trims	0.00	0.00
1	Cabinet Trims including	0.00	0.00

	Toe Kick Scribe Molding Filler Finish Panel *Quarter Round - Provide Material Only		
1	NO Quarter Round - Install	0.00	0.00
1	NO Crown Molding	0.00	0.00
1	NO Hardware or Handle	0.00	0.00
9	Total Unit of Cabinets Material	0.00	0.00
1	TOTAL CABINET MATERIAL WITH ASSEMBLING CABINET Delivery to Job Site	2,550.00	2,550.00
1	CABINET INSTALLATION FEE	800.00	800.00

ESTIMATE TOTAL

\$3,350.00

TERMS & CONDITIONS

COLOR AND SHADE VARIATION ARE INHERENT CHARACTERISTIC OF ALL CABINET AND NATURAL STONE PRODUCTS.INSPECT ALL MATERIAL BEFORE INSTALLATION. NO RETURN ON SPECIAL ORDER INTENS, NON-STOCKED MATERIAL.All dimensions size designations given are subject to verification on job site and adjustment to fit job conditions.

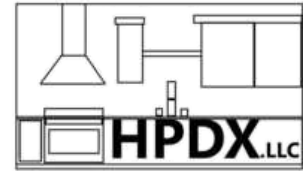

ESTIMATE #	211	ESTIMATE DATE	01/04/2026
P.O.#	#302		

BILL TO

HEART OF THE VALLEY PROPERTIES
Jim Abbott

SHIP TO

BRIGG BUILDING
333 W 1ST AVE #302
ALBANY OR 97321

HPDX.LLC

CCB# 254061



QTY	DESCRIPTION	UNIT PRICE	AMOUNT
1	White Shaker Cabinet - Upper Cabinet	0.00	0.00
1	W3021 - 30"(W)X21"(H) WALL CABINET DOUBLE DOOR	0.00	0.00
1	W2440 WALL CABINET DOUBLE DOOR	0.00	0.00
1	W3021 - 30"(W)X21"(H) WALL CABINET DOUBLE DOOR	0.00	0.00
1	GREY SHAKER CABINET - Base Cabinet	0.00	0.00
1	B27 - BASE CABINET SINGEL DOOR WITH DRAWER	0.00	0.00
1	DWP - DISHWASHER SIDE PANEL	0.00	0.00
1	Grey Shaker Cabinet - Bathroom Vanity	0.00	0.00
1	VA3021 - 30"(W)X21"(D)	0.00	0.00
1	Trims	0.00	0.00
1	Cabinet Trims including Toe Kick Scribe Molding Filler Finish Panel *Quarter Round - Provide Material Only	0.00	0.00
1	NO Crown Molding	0.00	0.00
1	NO Hardware or Handle	0.00	0.00
5	Total Unit of Cabinets Material	0.00	0.00

1	TOTAL CABINET MATERIAL WITH ASSEMBLING CABINET Delivery to Job Site	1,300.00	1,300.00
1	CABINET INSTALLATION FEE	800.00	800.00
4	Additional Cabinet	0.00	0.00
1	W2440 WALL CABINET DOUBLE DOOR	0.00	0.00
1	W2440 WALL CABINET DOUBLE DOOR	0.00	0.00
1	W2430 WALL CABINET DOUBLE DOOR	0.00	0.00
1	W2430 WALL CABINET DOUBLE DOOR	0.00	0.00
1	Special Build Toe Kick Box for W2430 Built Out W3021 to 24" Depth with refrigerator Panel	200.00	200.00
1	Total Cost Cabinets Material	1,000.00	1,000.00

ESTIMATE TOTAL

\$3,300.00

TERMS & CONDITIONS

COLOR AND SHADE VARIATION ARE INHERENT CHARACTERISTIC OF ALL CABINET AND NATURAL STONE PRODUCTS.INSPECT ALL MATERIAL BEFORE INSTALLATION. NO RETURN ON SPECIAL ORDER INTENS, NON-STOCKED MATERIAL.All dimensions size designations given are subject to verification on job site and adjustment to fit job conditions.

JY Granite and Cabinet Inc

Estimate

540 Grant Street Eugene, OR 97402  CCB#200718

Date	Estimate #
1/10/2026	15343

Name / Address
 333 W 1st Ave Albany, OR 97321

			Project
Description	Qty	Rate	Total
Unit 302			
Grey Base, White Upper			
White Cabinet Base 27"WX24"DX34-1/2"H-2D-1DRA-1S	1	405.00	405.00
White- Dish washer Panel 3"WX34.5"HX1/2"D	1	89.00	89.00
White- Vanity Sink Base W/Drawers 36"WX21"DX34-1/2"H 1 Door 2 Drawer	1	609.00	609.00
White- Filler 1"WX40"HX5/8"D	1	18.00	18.00
White- Toe Kick 4-3/8"WX96"HX1/8"D	1	29.00	29.00
White - Scribe Molding 8'	1	18.00	18.00
White- Quarter Round Molding 8'H	1	35.00	35.00
White Cabinet wall 30"WX22"HX12"D 2D	1	295.00	295.00
White Wall Microwave 30"WX40"HX12"D 2D 1S	1	365.00	365.00
White Cabinet wall 33"WX22"HX24"D 2D	1	325.00	325.00
White- Filler 1"WX40"HX5/8"D	1	18.00	18.00
White - Scribe Molding 8'	2	18.00	36.00
White- Crown Molding 3'	2	119.00	238.00
Subtotal			2,480.00
15% Discount		-15.00%	-372.00
Assembling & Installing Cabinets and panel	6	90.00	540.00
Finish the accessories	1	125.00	125.00
Install the handles	1	75.00	75.00
Travel Fee		100.00	100.00
Total			\$2,948.00

JY Granite and Cabinet Inc

Estimate

540 Grant Street Eugene, OR 97402  CCB#200718

Date	Estimate #
1/10/2026	15341

Name / Address
 333 W 1st Ave Albany, OR 97321

			Project
Description	Qty	Rate	Total
Unit 301			
Grey Base, White Upper			
White Cabinet Base Blind Corner 36"WX24"DX34.5"H 1D 1DRA 1S	1	470.00	470.00
White Cabinet Base 30"WX24"DX34-1/2"H-2D-1DRA-1S	1	415.00	415.00
White- Dish washer Panel 3"WX34.5"HX1/2"D	1	89.00	89.00
White- Vanity Sink Base W/Drawers 36"WX21"DX34-1/2"H 1 Door 2 Drawer	1	609.00	609.00
White- Filler 2"WX40"HX5/8"D	2	26.00	52.00
White- Toe Kick 4-3/8"WX96"HX1/8"D	1	29.00	29.00
White - Scribe Molding 8'	2	18.00	36.00
White- Quarter Round Molding 8'H	2	35.00	70.00
White Wall Microwave 30"WX42"HX12"D 2D 1S	1	365.00	365.00
White Cabinet Wall Blind Corner 27"WX40"HX12"D 1D 2S	1	365.00	365.00
White Cabinet wall 27"WX40"HX12"D 2D 2S	1	380.00	380.00
White Cabinet wall 30"WX22"HX12"D 2D	2	295.00	590.00
White- Filler 2"WX40"HX5/8"D	1	26.00	26.00
White - Scribe Molding 8'	2	18.00	36.00
White- Crown Molding 3'	2.5	119.00	297.50
Subtotal			3,829.50
15% Discount		-15.00%	-574.43
Subtotal			3,255.07
Assembling & Installing Cabinets and panel	9	90.00	810.00
Finish the accessories		125.00	125.00
Install the handles		75.00	75.00
Travel Fee		100.00	100.00
Total			\$4,365.07

JY Granite and Cabinet Inc

Estimate

540 Grant Street Eugene, OR 97402 [REDACTED] CCB#200718
--

Date	Estimate #
1/10/2026	15346

Name / Address
Abbott, Corina [REDACTED] 333 W 1st Ave Albany, OR 97321

			Project
Description	Qty	Rate	Total
Unit 202			
Grey Base and White Upper			
White Cabinet Base Wasterbasket 18"WX24"DX34.5"H 1 Drawer, 1 Door	1	345.00	345.00
White Cabinet Sink Base 36"WX24"DX34-1/2"H-2D-2Headers	1	439.00	439.00
White Cabinet Drawer Pack 27"WX24"DX34.5"H 3DRA	1	599.00	599.00
42" Blind base	1	500.00	500.00
White Cabinet Base 30"WX24"DX34-1/2"H-2D-1DRA-1S	1	415.00	415.00
45" Blind base	1	530.00	530.00
White- Vanity 3 Drawer Pack 12"WX21"DX34.5"H 3 Drawer	2	415.00	830.00
White- Vanity Sink Base 24"WX21"DX34-1/2"H 2D	1	380.00	380.00
White- Filler 3"WX96"HX5/8"D	1	99.00	99.00
White- Toe Kick 4-3/8"WX96"HX1/8"D	3	29.00	87.00
White - Scribe Molding 8'	2	18.00	36.00
White- Quarter Round Molding 8'H	4	35.00	140.00
White Cabinet wall 18"WX40"HX12"D 1D 2S	2	285.00	570.00
White Cabinet wall 33"WX40"HX12"D 2D 2S	2	435.00	870.00
White Cabinet Wall Blind Corner 27"WX30"HX12"D 1D 2S	2	329.00	658.00
White Cabinet wall 30"WX40"HX12"D 2D 2S	2	399.00	798.00
White Cabinet wall 30"WX22"HX12"D 2D	2	295.00	590.00
White- Filler 3"WX96"HX5/8"D	1	99.00	99.00
White- Filler 1"WX40"HX5/8"D	1	18.00	18.00
White - Scribe Molding 8'	2	18.00	36.00
White- Crown Molding 3'	4	119.00	476.00
Subtotal			8,515.00
15% Discount		-15.00%	-1,277.25
Assembling & Installing Cabinets and panel	19	90.00	1,710.00
Total			

JY Granite and Cabinet Inc

Estimate

540 Grant Street <div style="background-color: black; width: 100%; height: 20px; margin: 5px 0;"></div> CCB#200718

Date	Estimate #
1/10/2026	15346

Name / Address
Abbott Corina <div style="background-color: black; width: 100%; height: 15px; margin: 2px 0;"></div> 333 W 1st Ave Albany, OR 97321

Project

Description	Qty	Rate	Total
Finish the accessories	1	225.00	225.00
Install the handles	1	150.00	150.00
Travel Fee		100.00	100.00
Total			\$9,422.75

JY Granite and Cabinet Inc

Estimate

540 Grant Street <div style="background-color: black; width: 100%; height: 20px; margin: 5px 0;"></div> CCB#200718

Date	Estimate #
1/10/2026	15348

Name / Address
<div style="background-color: black; width: 100%; height: 20px; margin-bottom: 5px;"></div> 333 W 1st Ave Albany, OR 97321

			Project
Description	Qty	Rate	Total
Unit 201			
Grey Base and White Upper			
White Cabinet Base 24"WX24"DX34-1/2"H-2D-1DRA-1S	2	399.00	798.00
White Cabinet Base Blind Corner 36"WX24"DX34.5"H 1D 1DRA 1S	2	470.00	940.00
White Cabinet Drawer Pack 18"WX24"DX34.5"H 3DRA	1	490.00	490.00
White Cabinet Sink Base 36"WX24"DX34-1/2"H-2D-2Headers	1	439.00	439.00
White Cabinet Base Wasterbasket 18"WX24"DX34.5"H 1 Drawer, 1 Door	1	345.00	345.00
White Cabinet Base 30"WX24"DX34-1/2"H-2D-1DRA-1S	1	415.00	415.00
White- Vanity Sink Base W/Drawers 36"WX21"DX34-1/2"H 1 Door 2 Drawer	2	609.00	1,218.00
White- Filler 3"WX96"HX5/8"D	1	99.00	99.00
White- Base End Panel 96"WX48"HX3/16"D	1	215.00	215.00
White- Outside Corner Molding 8'	1	40.00	40.00
White- Toe Kick 4-3/8"WX96"HX1/8"D	4	29.00	116.00
White - Scribe Molding 8'	3	18.00	54.00
White- Quarter Round Molding 8'H	6	35.00	210.00
White Cabinet wall 36"WX40"HX12"D 2D 2S	2	455.00	910.00
White Cabinet wall 18"WX40"HX12"D 1D 2S	1	285.00	285.00
White Cabinet Wall Blind Corner 27"WX40"HX12"D 1D 2S	1	365.00	365.00
White Cabinet wall 27"WX40"HX12"D 2D 2S	1	380.00	380.00
White Cabinet wall 30"WX22"HX12"D 2D	1	295.00	295.00
White Cabinet wall 30"WX40"HX12"D 2D 2S	1	399.00	399.00
White Cabinet wall 33"WX22"HX24"D 2D	1	325.00	325.00
White- Filler 2"WX40"HX5/8"D	1	26.00	26.00
White - Scribe Molding 8'	2	18.00	36.00
White- Crown Molding 3'	3	119.00	357.00
		Total	

JY Granite and Cabinet Inc

Estimate

540 Grant Street Eugene, OR 97402 [REDACTED] CCB#200718
--

Date	Estimate #
1/10/2026	15348

Name / Address
Abbott, Corina [REDACTED] 333 W 1st Ave Albany, OR 97321

Project

Description	Qty	Rate	Total
Subtotal			8,757.00
15% Discount		-15.00%	-1,313.55
Assembling & Installing Cabinets and panel	19	90.00	1,710.00
Finish the accessories		225.00	225.00
Install the handles		150.00	150.00
Travel Fee		100.00	100.00
Total			\$9,628.45

JY Granite and Cabinet Inc

Estimate

540 Grant Street
 Eugene, OR 97402
 [REDACTED]
 CCB#200718

Date	Estimate #
1/10/2026	15344

Name / Address
 Abbott Corina
 [REDACTED]
 333 W 1st Ave
 Albany, OR 97321

Project

Description	Qty	Rate	Total
Unit 302			
Calacatta Imperial- Quartz	1	769.00	769.00
110"X26"-3cm			
15% Discount		-15.00%	-115.35
Installation of 26"X3cm Slab	1	300.00	300.00
Cutting Under-Mount for Kitchen	1	300.00	300.00
Cut Under-Mount for Bathroom	1	225.00	225.00
Polish	2	20.00	40.00
Subtotal			1,518.65
10% Discount		-10.00%	-151.87
18G Stainless Steel Single Bowl Square 23."X18"X9" (802)	1	145.00	145.00
Under Mount Porcelain Square Sink 460mmX370mmX180mm (White)	1	75.00	75.00
Note: no backsplash			
		Total	\$1,586.78

JY Granite and Cabinet Inc

Estimate

540 Grant Street [REDACTED] CCB#200718
--

Date	Estimate #
1/10/2026	15342

Name / Address
Abbott Corina [REDACTED] 333 W 1st Ave Albany, OR 97321

			Project
Description	Qty	Rate	Total
Unit 301			
Calacatta Imperial- Quartz 110"X26"-3cm	1.5	769.00	1,153.50
Subtotal			1,153.50
15% Discount		-15.00%	-173.03
Installation of 26"X3cm Slab	1.5	300.00	450.00
Cutting Under-Mount for Kitchen	1	300.00	300.00
Cut Under-Mount for Bathroom	1	225.00	225.00
Seam	1	50.00	50.00
Subtotal			1,025.00
10% Discount		-10.00%	-102.50
18G Stainless Steel Single Bowl Square 23."X18"X9" (802)	1	145.00	145.00
Under Mount Porcelain Square Sink 460mmX370mmX180mm (White)	1	75.00	75.00
Note: no backsplash			
Total			\$2,122.97

JY Granite and Cabinet Inc

Estimate

540 Grant Street Eugene, OR 97402  CCB#200718

Date	Estimate #
1/10/2026	15347

Name / Address
Abbott Corina  333 W 1st Ave Albany, OR 97321

			Project
Description	Qty	Rate	Total
Unit 202			
Calacatta Imperial- Quartz 110"X26"-3cm	3	769.00	2,307.00
Subtotal			2,307.00
15% Discount		-15.00%	-346.05
Installation of 26"X3cm Slab	3	300.00	900.00
Cutting Under-Mount for Kitchen	1	300.00	300.00
Cut Under-Mount for Bathroom	1	225.00	225.00
Polish	6	20.00	120.00
Seam	2	50.00	100.00
Subtotal			1,645.00
10% Discount		-10.00%	-164.50
18G Stainless Steel Single Bowl Square 29."X18"X10"	1	175.00	175.00
Under Mount Porcelain Square Sink 460mmX370mmX180mm (White)	1	75.00	75.00
Note: not backsplash			
Total			\$3,691.45

JY Granite and Cabinet Inc

Estimate

540 Grant Street Eugene, OR 97402 [REDACTED] CCB#200718
--

Date	Estimate #
1/10/2026	15349

Name / Address
Abbott Corina [REDACTED] 333 W 1st Ave Albany, OR 97321

			Project
Description	Qty	Rate	Total
Unit 201			
Calacatta Imperial- Quartz 110"X36"-3cm	1	1,015.00	1,015.00
Calacatta Imperial- Quartz 110"X26"-3cm	2.5	769.00	1,922.50
Subtotal			2,937.50
15% Discount		-15.00%	-440.63
Installation of 36"X3cm Island	1	350.00	350.00
Installation of 26"X3cm Slab	2.5	300.00	750.00
Cutting Under-Mount for Kitchen	1	300.00	300.00
Cut Under-Mount for Bathroom	2	225.00	450.00
Polish	6	20.00	120.00
Seam	2	50.00	100.00
Subtotal			2,070.00
10% Discount		-10.00%	-207.00
18G Stainless Steel Single Bowl Square 29."X18"X10"	1	175.00	175.00
Under Mount Porcelain Square Sink 460mmX370mmX180mm (White)	2	75.00	150.00
Note: no backsplash			
Total			\$4,684.87



Juliette Balcony specs from MMC

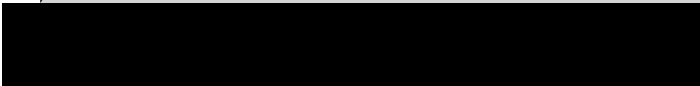

Sun, Mar 29, 2026 at 11:40 PM

These balconies will be \$881.95 each, plus \$100 delivery fee. Shipping included, no installation.

----- Forwarded message -----

From: **Corina Abbott** 

Date: Wed, Jan 28, 2026 at 6:20 PM

Subject: Juliette Balcony specs from MMC

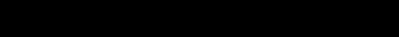
To: Matt Johnson 

[Quoted text hidden]

[Quoted text hidden]

[Quoted text hidden]

 **C10 Juliette Balcony-72W-42T 3IN Offset Model (1) - C10 Juliette Balcony-72W-42T 3IN Offset Brosco.pdf**
44K

Project Question - Request for Help

Scott Campbell <
To: James Abbott 

Wed, Oct 15, 2025 at 11:30 AM

Hi Jim!

Just wanted to get back to you with a price guess. I used CoPilot to help me crunch some numbers. We've come up with a number of \$3500 (design, labor and materials to make the cornice) for the front facing cornice. This includes some contingency given I don't know exactly how this will go. Will the window trim be of the same process?

-Scott

[Quoted text hidden]

CCB#66298

Proposal #52877

SALEM TENT & AWNING

SERVING THE WILLAMETTE VALLEY SINCE 1890

• PO Box 5274 • 280 Wallace Rd NW Salem OR 97304 •

Bill To

ABBOTT , CORINA
POLYNOVATION LLC
333 W 1ST AVE
Albany , OR 97321

Ship To

ABBOTT , CORINA
POLYNOVATION LLC
333 W 1ST AVE
Albany , OR97321

<u>Written By</u>	<u>Sale Date</u>	<u>Pattern</u>	<u>Border</u>	<u>Frame</u>	<u>Recover</u>	<u>Installation</u>
CLIFF	1/22/2026	TEMPOTEST	HEMMED	PIPE		ST&A

Description	QTY	Price	Extended Amount
<i>We hereby submit specifications and estimates for:</i>			
PIPE FRAME AWNINGS FOR STORE FRONT & BACK.			
FRONT; 5' DROP X 5' PROJECTION X 23' -1" WIDE, 13 ARMS & BRACES.	1	\$3,908.00	\$3,908.00
REAR; 3' DROP X 4' PROJECTION X 10'-6" WIDE, 7 ARMS & BRACES.	1	\$2,041.00	\$2,041.00
PRICES INCLUDE INSTALLATION, DO NOT INCLUDE ANY PERMIT & ENGINEERING COSTS.			

We hereby Propose to furnish labor and materials- complete in accordance with the above specifications, with payment to be made as follows: **1/2 down with the balance upon completion.**

All material is guaranteed to be as specified. All work to be completed in a workmanlike manner according to standard practices. Any alteration or deviation from above specifications involving extra costs will be executed on upon written orders, and will become an extra charge over and above the estimate. All agreements contingent upon strikes, accident, or delays beyond our control. This proposal subject to acceptance within 30 DAYS and is void thereafter at the option of the undersigned.

Proposal By _____

Acceptance Of Proposal

The above prices, Specifications, and conditions are hereby accepted. You are authorized to do the work as specified. Payment will be made as outlined above. Also I acknowledge that I have received if applicable the following Disclosures (ORS 87.093) , (ORS 701.330) & (ORS 701.330(1))

ACCEPTED DATE: _____

SIGNATURE: _____

Estimated Completion Date: _____

Subtotal	\$5,949.00
Shipping	
Total	\$5,949.00

Information Notice To Owner About Construction Liens (ORS 87.093)

This is not a lien. Your contractor is required by law to provide this notice to inform you about construction lien laws. This notice explains the construction lien law, and gives steps you can take to protect your property from a valid lien. As an owner, you should read this information notice carefully. This information notice is required to be given if you contract for residential construction or remodeling, if you are buying a new home, or at any time the contract price exceeds \$2,000.

- Under Oregon law, your contractor and others who provide labor, materials, equipment, or services to your project may be able to claim payment from your property if they have not been paid. That claim is called a Construction Lien.
- If your contractor does not pay subcontractors, employees, rental equipment dealers, materials suppliers, or does not make other legally required payments, those who are owed money may place a lien against your property for payment. **It is in your best interest to verify that all bills related to your contract are paid, even if you have paid your contractor in full.**
- If you occupy or will occupy your home, persons who supply materials, labor, equipment, or services ordered by your contractor are permitted by law to file a lien against your property only if they have sent you a timely Notice of Right to Lien (which is different from this Information Notice), before or during construction. If you enter into a contract to buy a newly-built, partially-built, or newly-remodeled home, a lien may be claimed even though you have not received a Notice of Right to a Lien. If you do not occupy the building, a Notice of Right to Lien is not required prior to filing a lien.

This notice is not intended to be a complete analysis of the law. You should consult an attorney for more information.

Common Questions and Answers About Construction Liens

Can someone record a construction lien even if I pay my contractor? Yes. Anyone who has not been paid for labor, material, equipment, or services on your project and has provided you with a valid Notice of Right to Lien has the right to record a construction lien.

What is a Notice of Right to Lien? A Notice of a Right to Lien is sent to you by persons who have provided labor, materials, or equipment to your construction project. It protects their construction lien rights against your property.

What should I do when I receive a Notice of Right to Lien? Don't ignore it. Find out what arrangements your contractor has made to pay the sender of the Notice of Right to Lien.

When do construction liens need to be recorded? In Oregon, construction liens generally need to be recorded within 75 days from the date the project was substantially completed, or 75 days from the date that the lien claimant stopped providing labor, material, equipment, or services, whichever happened first. To enforce a lien, the lien holder must file a lawsuit in a proper court within 120 days of the date the lien was filed.

Note to Contractor: This notice must be delivered personally, or mailed by registered mail, certified mail, or by first-class mail with a certificate of mailing. Ask the signing parties to provide you with an original or copy to retain in your files. You should retain proof of delivery of this notice for at least two years.

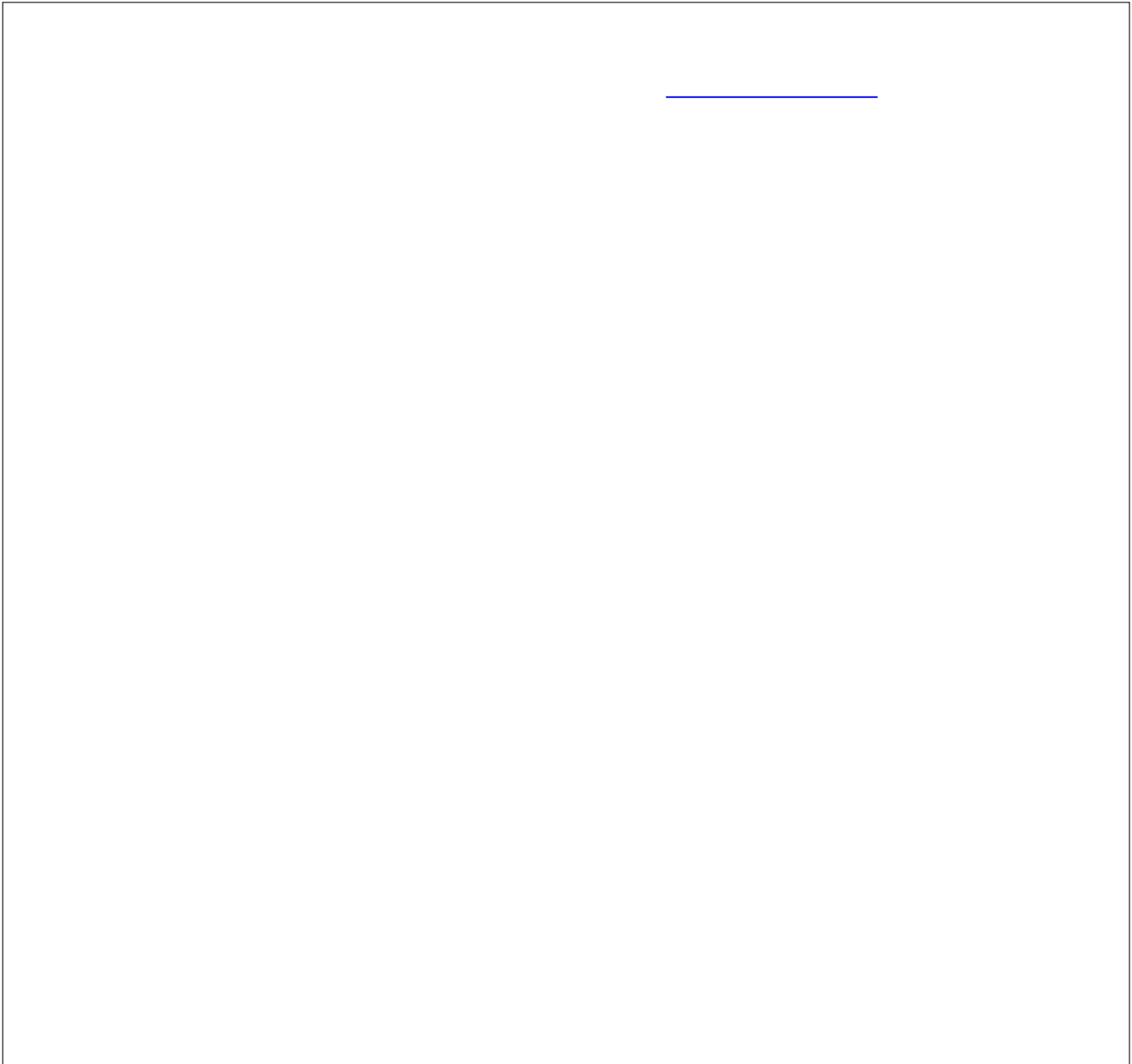

66298

Salem Tent and Awning Co.

Deric Cruikshank



66298

Salem Tent and Awning Co.

Deric Cruikshank



Consumer Protection Notice

Actions to help make your project successful

(ORS 701.330 (1))

Oregon law requires contractors to provide the homeowner with this notice at the time of written contract, for work on a residential structure. This notice explains licensing, bond and insurance requirements, and steps that consumers can take to help protect their interests.

START OUT YOUR PROJECT RIGHT

1. **Make sure your contractor is properly licensed** before you sign a contract. Visit www.oregon.gov/ccb, and click on the link, **Check on a Contractor's License**, or call our offices at 503-378-4621. To be licensed in Oregon, contractors must take training and pass a test on business practices and law. Licensing is not a guarantee of the contractor's work.
 - **A license requires the contractor to maintain a surety bond and liability insurance** - The CCB surety bond provides a limited amount of financial security if the contractor is ordered to pay damages in contract disputes. It is not intended to be a safety net for consumer damages. Consumers with large projects may wish to look into performance bonds. Liability insurance coverage provides for property damage and bodily injury caused by the contractor. It does not cover contract disputes, including poor workmanship.
 - **If your contractor is not licensed** - the CCB bond and dispute resolution services will not be available to you.
2. **What you should know about bids, contracts, and change orders:**
 - **Bids** - *Do not automatically accept the lowest bid* - A low bid may make it necessary for the contractor to use lower quality materials and to cut corners in workmanship.
 - **Contracts and Change Orders** - **Always get it in writing**. Your contractor is required to provide a written contract if the contract price is more than \$2000. The CCB recommends that all contracts be in writing.
 - **Contracts should be as detailed as possible** - Some items to include are materials and costs, permits, estimated start and completion dates, debris removal, and arbitration clauses. Make sure the contractor's name, CCB number, and contact information is included in the contract.
 - **Read and understand your contract before signing it** - Don't be pressured into signing your contract without taking the time needed to go through it. Make sure it includes enough details to avoid misunderstandings and to protect you and your property.
3. **Additional contract information you should know:**
 - **A Payment Schedule** - should be included in the contract. Stick to the schedule and never pay in full for a project before the work is complete.
 - **Special Note on Liens** - Subcontractors and material suppliers that work on your project are often paid by the general contractor. If a general contractor fails to pay, the subcontractor may file a lien on your property. For information on construction liens, visit the CCB's Consumer Help Page at www.oregon.gov/ccb, or contact an attorney.
 - **Warranty on new residential construction** - Contractors must make an offer of a warranty when constructing a new residential structure. Consumers may accept or refuse the warranty.
4. **If you should have a problem with your contractor** - You can file a complaint with the CCB against a licensed contractor within one year of the substantial completion of work on your project. Contact the CCB office at 503-378-4621 for help.

Visit the CCB website at for more information on having a successful project.
www.oregon.gov/ccb

CONTRACTOR: CCB#: **66298**

PROPERTY OWNER:

Deric Cruikshank

Signature

Date

Signature

Date

Cost Estimate
Historic Brick Wall Repair and Install of STAS Wall Mounting System
 1875 John Briggs Building
 333 1st Ave Albany, Oregon

Purpose: The historic brick wall on the East side of the building is well over 150 years old, predating the construction of the John Briggs building that was completed in 1875. Over the many years, the brick wall has been damaged from repeated wall mounting systems that were pounded and drilled into it. We propose to preserve the wall by making gentle repairs, and then installing a ceiling-mounted rail hanging system so that artwork and product displays can be hung in front of the brick wall from the ceiling, instead of mounted into the wall itself.

Item	Cost/unit	Units	Cost
Cleaning and repointing the brick wall. This will be done with mortar that is softer than the original Albany brick, making the mortar the sacrificial component of the wall, not the brick. High 13' ceiling, ~35' length. Estimate 2 days of work.	\$125.00	16	\$2,000.00
STAS prorail flat white + installation kit 78.75"	\$56.15	5	\$280.75
STAS steel cable + STAS zipper hook 157.48"	\$18.18	10	\$181.80
Installation of new mounting system - High, 13 foot ceiling	\$125.00	3	\$450.00
		Total:	\$2,912.55



Project Evaluation Grid: 333 1st Avenue W

Request: 281,357.21

	Item	Description	Staff Analysis/Comments
<i>Overall Goals</i>			
A)	<p>CARA Goal & Objectives: The purpose of this CARA Plan is to eliminate blighting influences found in the CARA, to implement goals and objectives of the City of Albany Comprehensive Plan, and to implement development strategies and objectives for the CARA. The goal and objectives for the CARA have been defined as follows:</p> <p>CARA Goal: To revitalize the Central Albany Revitalization Area by implementing the Town Center Plan developed through the Central Albany Land Use & Transportation Study (CALUTS) using a citizen-driven process.</p>	<p>Does the project further the Town Center Plan?</p> <p>Which of CARA's objectives does the project meet?</p> <p>CARA Key Objectives:</p> <ul style="list-style-type: none"> ◆ Attract new private investment to the area. ◆ Retain and enhance the value of existing private investment and public investment in the area. <p>CARA Additional Objectives:</p> <ul style="list-style-type: none"> ◆ Provide a safe and convenient transportation network that encourages pedestrian & bicycle access to and within the town center. ◆ Preserve the Historic Districts, historic resources and existing housing in the area. ◆ Create a readily identifiable core that is unique and vibrant with a mixture of entertainment, housing, specialty shops, offices, and other commercial uses. ◆ Increase residential density in the area. ◆ Encourage the development of new forms of housing and home ownership. ◆ Enhance and protect the community and environmental values of waterway corridors in the area. ◆ Provide an enriching environment and livable neighborhoods. 	<p>Yes.</p> <p>This project meets CARA's two key objectives as listed.</p> <p>Additional objectives met:</p> <p>Historic preservation Readily identifiable core Increase residential density Enriching environment</p>
B)	CARA Planned Projects	Which project category and activity in the UR Plan does this project fulfill? (See CARA Project Activities document, or Table 2 of the UR Plan and Report.)	Commercial Building Rehabilitation, Storefront Revitalization, Housing Rehabilitation
C)	Development Pattern (Highest and Best Use)	Does it achieve desired land use (e.g., mixed-use, higher density) and/or transportation objectives (e.g., Esplanade, pedestrian-friendly areas)? Is the proposed project desired in this location and the highest and best use of the property?	Zone: Historic Downtown Yes, proposed project fits within highest and best use options for the property.
D)	Blight	Would it remedy a severely blighted building? How? Does the project utilize a vacant space?	Yes, this project will help remedy a severely blighted building.

E)	Preservation	Would it rehabilitate or sensitively redevelop a historic property?	Yes.
F)	Vitality/People Attractor	Does the general public benefit (i.e. restaurant, carousel, something they can go to; does the project enhance the public's experience of the space; is it a business we are seeking)?	Yes, will support a new interior design business coming to Albany.
G)	Retail Hotspot (First Avenue between Lyon and Calapooia)	Is the project located in the Retail Hotspot? If so, will the first floor use be active retail, as recommended in the Retail Refinement Plan?	Yes. No, not active retail on the first floor.
H)	Sustainable Building	Will the building be built using sustainable practices including LEED or others?	Not addressed in application.
I)	Residential	Is there a residential component? How many units?	Yes, 4 new or fully renovated units.
<i>Economic Development</i>			
J)	Bring new business to Albany	Will a new business open or come to Albany as a part of this project?	Yes.
K)	Job Creation	Will the project create additional jobs? How many, what types and what salary level?	1-2 full time positions. Salary levels not indicated in application.
L)	Local Labor and Materials	Has applicant specifically called out a commitment to use a certain percent or amount of local labor and/or materials?	Not specifically called out in application.
<i>Financial</i>			
M)	Ratio	Proposed public funds Private funds % of CARA Investment	Applicant requesting 75% of total project costs in this phase
N)	Financial Impacts	What are the financial risks and/or financial benefits to CARA?	Reimbursement based-grant; low financial risk. Benefits through increased value.
O)	Gap	What is the "Gap" or need of the developer?	\$281,357.21
P)	Private Risk	What is the risk for the developer? What is their skin in the game?	\$93,785.74 in this phase of the project.
Q)	CARA/City funds	Has the project received other CARA/City funding in the past?	No.
R)	Tax Increment ROI	Is the ROI on this project less than 5 years, less than 7 years?	ROI will be achieved through increased property value.



CARA GRANT APPLICATION

1. APPLICANT

Name: John and Sharon Pascone

Mailing Address: _____

Zip Code: _____

Title: owners

Phone Number: _____

E-mail Address: _____

2. BUSINESS/BUILDING INFORMATION

Legal Business Name: _____

Number of Years in Operation: _____

Legal Form: Sole Proprietorship Partnership Corporation S-Corp LLC
 Profit Nonprofit

EIN: na

In which state are the incorporation and/or organization documents filed? _____

Have you ever filed for bankruptcy? Yes No

Project Address (if different than mailing address): 343 1st Ave W

Property Tax Account Number: R80834

Is the building a historic contributing resource? Yes No

If so, is it on the historic property-tax freeze? Yes No

3. OWNER OF PROPERTY (if not applicant)

Name in which title is held: _____

Contact Name: _____

Mailing Address: _____

Zip Code: _____

Phone Number: _____

4. AUTHORIZATION TO UNDERTAKE WORK:

If the applicant is not the owner of the property, provide written evidence that the owner authorizes this work to be undertaken. (Typically this is in the form of a lease or other written permission.)

5. DESCRIPTION OF PROJECT *Please give a comprehensive description of project.*

The building has a very old sewer line with a failing P trap in it and with age and settling it plugs up often.
 It has plugged up several times in the past year and seems to occur more often, which is a new problem, not deferred maintenance.
 There is no clean out in the old line.

Each episode costs \$350 or more to unplug the line. Office staff and the residents upstairs need to use facilities elsewhere when waiting for it to be cleaned out.

The fix involves shoring up the building, removing a concrete column and trenching in from the street to replace the line and adding a cleanout.

6. TIMELINE FOR COMPLETION OF PROJECT: May 2027

7. PROJECT COSTS

ESTIMATED COST OF PROJECT: \$ 12,960

ESTIMATED VALUE OF PROJECT UPON COMPLETION: \$ 30,000

Basis for valuation and value upon completion: A new sewer line with a clean out has immeasurable value, a failing sewer line has no value.

SOURCES FOR PROJECT:

Owner/Company Contribution	<u>\$ 3,240</u>
Bank (estimated)	<u>\$</u>
Other private funds (please specify)	<u>\$</u>
Other governmental (please specify)	<u>\$</u>
CARA (proposed)	<u>\$ 9,720</u>
TOTAL SOURCES	<u>\$ 12,960</u>

Is your funding for these: available today applied for unknown at this time

USES FOR PROJECT:

Land and/or Building Acquisition	<u>\$</u>
Soft Costs (architectural, engineering, financing, and legal fees, and other pre- and post-construction expenses.) *	<u>\$</u>
Construction Costs *	<u>\$ 12,960</u>
Tenant Improvements	<u>\$</u>
Machinery/Equipment/Installation Costs	<u>\$</u>
Working Capital	<u>\$</u>
Other (please specify)	<u>\$</u>
TOTAL USES	<u>\$ 12,960</u>

*Please provide a detail of Soft Costs and of Construction Costs (Please attach).

8. PREPARATION OF COST ESTIMATES

Who prepared your cost estimates? Stutzman Services, Knox Construction

(If applicant prepared their own estimate, verification may be required. **Please attach minimum of two bids, preferably three.**)

Mailing Address: see estimates attached

Phone Number: _____ E-mail Address: _____

9A. EXPLAIN WHY CARA FUNDING IS NECESSARY TO INSURE PROJECT COMPLETION.

(Please provide a description of the financial gap requiring CARA assistance.)

This is an important historic downtown building c.1879, with lots of character and with ghost signs on it; Murphy's Seed Store.

We have put a lot of money into the building; restored the store front, rebuilt the deck and railings, new HVAC unit, etc.

CARA funding will help resolve the the issue permanently and preserve the functionality of the building and plumbing for years to come.

9B. IF YOU DON'T RECEIVE THE FUNDS, WHAT COMPONENTS WILL BE DROPPED? WOULD THE PROJECT GET DONE WITHOUT CARA FUNDS? (Please provide a detailed explanation.)

If we don't get funding help the problem will persist with temporary fixes as long as possible.

It would create a health hazard in the downtown if the sewer line failed.

14. ASSISTANCE REQUESTED

Total Estimated Project Costs:	\$ <u>12,960</u>
Your Total Contribution	\$ <u>3,240</u>
Total Amount Requested from CARA:	\$ <u>9,720</u>

Final payment will be based on actual costs not estimates. **Ten percent of CARA funds will be held back for final payment.**

15. BREAKDOWN OF USE OF CARA FUNDS

CARA funds can only be used for permanent improvements to the building. Please provide a breakout with specific details of how the CARA funds will be used in the project. If more space is needed, please attach a separate page.

Item	Amount	Notes
Shoring up Building	2,363	removing column and replacing with new columns and beams.
Plumbing, excavation	7,357	street repair
TOTAL	9,720	Total should match total amount requested from CARA from line 14.

Metrics and Other Benefits

If you receive funding, you will be asked to tally the final figures on the project and certify their accuracy. Please use this space to estimate the impact of your project:

Number of Jobs Created: 0 Full-time 0 Part-Time

10. WHERE ELSE HAVE YOU LOOKED FOR FUNDING?

City of Albany Public Works department.
Sewer lateral replacement program is not for this purpose.

11. CONSIDERING THE PROJECT GOALS OUTLINED IN THIS APPLICATION, PLEASE IDENTIFY THE VALUE YOUR PROJECT BRINGS TO CARA.

Historic preservation and fully functional properties are very important to CARA's mission and goals.
Fully occupied buildings with happy tenants are important to the viability of the area.
If tenants leave because of unsafe or unattractive buildings the whole area suffers.

12. PLEASE OUTLINE ANY OTHER BENEFITS YOUR PROJECT PROVIDES.
(To Albany, and the area/neighborhood)

Local labor benefits using Stutzman Services and Knox Construction, who are currently working on a large project next door.
While no permanent jobs will be created, local wages will be paid and materials purchased.

13. HAVE YOU OR THIS PROPERTY RECEIVED CARA FUNDING AT ANY POINT IN THE PAST?

No Yes If so, amount \$ _____

FOR WHAT PROJECT(S): _____

WHEN? _____

Certification

The Applicant understands and agrees to the following conditions:

1. Any physical improvements proposed must be approved by the Albany Revitalization Area Agency (ARA) and may require approval by the City of Albany Landmarks Advisory Commission or other entities. These entities may require certain changes or modifications before final approval and Commitment of Funds.
2. Any work begun before receipt of a Contract notice is ineligible for reimbursement.
3. Any work deviating from that detailed in the Contract must be preapproved in writing to be eligible for reimbursement.
4. While only proprietary information may be held in confidence outside of the public record, ARA will attempt to maintain all information provided in a confidential manner.
5. Originals of all materials prepared with ARA assistance belong to ARA and will be maintained in the public record.
6. Application must be completed in its entirety before being considered; if not, it will be returned for completion.
7. Staff is authorized to independently verify any and all information contained in this application.
8. ARA may withhold approval of this application until information satisfactory to ARA is provided.

The Applicant certifies that all information in this application and all information furnished in support of this application is given for the purpose of obtaining ARA assistance and is true and complete to the best of the Applicant's knowledge. Applicant further acknowledges the undersigned applicant(s) have read and understand CARA's privacy policy and have completed this form with accurate information.

John Pascone

Sharon Pascone

Applicant's Printed Name

Applicant's Printed Name

Applicant's Signature



Date 3/25/2026

Applicant's Signature

Date 3/25/2026

Return application/attachments to: City of Albany c/o Sophie Adams, Economic Development Manager: sophie.adams@albanyoregon.gov



Stutzman Services, Inc.
4185 Spicer Drive SE
Albany, Oregon 97322



CCB# 31747 | LCB# 5034

BILL TO

John Pascone
2667 Northwest Crocker Lane
Albany, OR 97322 USA

ESTIMATE 147389345	ESTIMATE DATE Mar 06 2026
------------------------------	-------------------------------------

JOB ADDRESS

John Pascone
343 West 1st Avenue
Albany, OR 97321 USA

Project: 144979555

ESTIMATE DETAILS

SEWER REPAIR (REVISED 3/6/2025): Scope of Work

Stutzman Services Inc. (SSI) will replace approximately 20 feet of existing 4-inch cast iron piping under the building with new 4-inch ABS piping.

Work will include excavating to an approximate depth of 5 feet to remove the existing problematic trap and tie into the existing 6-inch sewer line exiting the building.

Included Work

- Excavate under the building as required to access existing piping
- Demo and remove existing concrete footing as needed to access the excavation area
- Remove existing cast iron pipe and dispose of material
- Install new 4-inch ABS drain piping
- Connect new piping to existing 6-inch sewer line
- Backfill excavation with native soil
- Backfill placed in approximately 6-inch lifts and compacted to the extent possible
- Hand compaction of native soil to accommodate future footing replacement

Exclusions & Notes

- This price does not include post removal or temporary support of the building
- SSI will hand compact native soil in 6-inch lifts; however, SSI cannot guarantee 100% compaction
- Per conversation between Brent and Duane (Knox Brothers Construction), hand-compacted native soil is expected to be sufficient for footing replacement
- SSI cannot be held responsible for future soil settling
- Concrete replacement and footing restoration by others

TOTAL \$10,327.00
FRIENDS & FAMILY DISCOUNT 5% (\$516.35)
SUB-TOTAL \$9,810.65

SERVICE	DESCRIPTION	QTY
DRN	<p>Stutzman Services Inc. (SSI) will replace approximately 20 feet of existing 4-inch cast iron piping under the building with new 4-inch ABS piping.</p> <p>Work will include excavating to an approximate depth of 5 feet to remove the existing problematic trap and tie into the existing 6-inch sewer line exiting the building.</p>	1.00

#	DESCRIPTION
F&F	<p>Friends & Family: Friends & Family Discount</p>

SUB-TOTAL	\$9,810.65
TOTAL	\$9,810.65

Thank you for trusting Stutzman Services, Inc.
CUSTOMER AUTHORIZATION

This is a proposal for Stutzman Services to perform the work as described at 343 West 1st Avenue, Albany, OR 97321 USA. The upfront, flat rate price of \$9,810.65 is based on evaluation made prior to the proposal and includes everything required to follow industry best practices and complete the job including travel, labor, tools, equipment and materials. This proposal is valid for up to 14 days from the Estimate Date shown. Due to rapidly-changing costs and availability of materials, supplies and fuel, the price of this proposal may be adjusted if it is not accepted within 14 days. If the scope of the work changes significantly from what is specified in this proposal, an additional proposal will be required. A deposit of 50% is required upon acceptance of this proposal for all work totaling \$2,000 and over. Stutzman Services holds all the licenses, certifications and insurance necessary to operate in the state of Oregon. By signing below, you acknowledge that: 1) You have read and understand this proposal, 2) The proposed price, specifications and conditions are satisfactory, 3) You accept this proposal and authorize the work to be performed, and 4) You agree to pay the full amount specified.

Sign here _____

Date _____



**36185 BOHLKEN DRIVE
LEBANON, OR 97355**

CCB # 55194

DATE: 3-11-2026

PROPOSAL SUBMITTED TO:
John Pascone

WORK TO BE PERFORMED AT:
343 1st Ave SW
Albany, OR 97321

Proposal to support floor beam in crawlspace in preparation for sewer repair. Proposal includes—

- Excavate soil as needed to form and pour 2 concrete footings. Provide materials and labor to complete footings. All spoils to remain in crawlspace.
- Provide materials and labor to install posts and beam on top of new footings to support existing floor beam. New beam to be approximately 10' long to provide clearance for sewer repair.

_____ INITIAL HERE TO ACKNOWLEDGE RECEIPT OF **NOTICE OF PROCEDURE, CONSUMER PROTECTION NOTICE, AND INFORMATION NOTICE TO OWNER ABOUT CONSTRUCTION LIENS** BROCHURES

ALL MATERIAL IS GUARANTEED TO BE AS SPECIFIED, AND THE ABOVE WORK TO BE PERFORMED IN ACCORDANCE WITH THE DRAWINGS AND SPECIFICATIONS SUBMITTED FOR THE ABOVE WORK AND COMPLETED IN A SUBSTANTIAL WORKMANLIKE MANNER FOR THE SUM OF: **Three thousand one hundred fifty dollars (\$3,150.00).**

PAYMENT TO BE MADE AS FOLLOWS: Due Upon Receipt of KCI Invoice, prior to the 10th of the Month. A monthly 1.5% service charge shall be added for invoices more than 30 days past due.

THIS PROPOSAL MAY BE WITHDRAWN IF NOT ACCEPTED WITHIN 20 DAYS.

RESPECTFULLY SUBMITTED, **KNOX CONST., INC.**

PER _____

ACCEPTANCE OF PROPOSAL:

THE ABOVE PRICES, SPECIFICATIONS AND CONDITIONS ARE SATISFACTORY AND ARE HEREBY ACCEPTED. YOU ARE AUTHORIZED TO DO THE WORK AS SPECIFIED. PAYMENTS WILL BE MADE AS OUTLINED ABOVE.

SIGNATURE _____ SIGNATURE _____

DATE _____ DATE _____



Project Evaluation Grid: 343 1st Avenue W

Request: \$9,720

	Item	Description	Staff Analysis/Comments
<i>Overall Goals</i>			
A)	<p>CARA Goal & Objectives: The purpose of this CARA Plan is to eliminate blighting influences found in the CARA, to implement goals and objectives of the City of Albany Comprehensive Plan, and to implement development strategies and objectives for the CARA. The goal and objectives for the CARA have been defined as follows:</p> <p>CARA Goal: To revitalize the Central Albany Revitalization Area by implementing the Town Center Plan developed through the Central Albany Land Use & Transportation Study (CALUTS) using a citizen-driven process.</p>	<p>Does the project further the Town Center Plan?</p> <p>Which of CARA's objectives does the project meet?</p> <p>CARA Key Objectives:</p> <ul style="list-style-type: none"> ◆ Attract new private investment to the area. ◆ Retain and enhance the value of existing private investment and public investment in the area. <p>CARA Additional Objectives:</p> <ul style="list-style-type: none"> ◆ Provide a safe and convenient transportation network that encourages pedestrian & bicycle access to and within the town center. ◆ Preserve the Historic Districts, historic resources and existing housing in the area. ◆ Create a readily identifiable core that is unique and vibrant with a mixture of entertainment, housing, specialty shops, offices, and other commercial uses. ◆ Increase residential density in the area. ◆ Encourage the development of new forms of housing and home ownership. ◆ Enhance and protect the community and environmental values of waterway corridors in the area. ◆ Provide an enriching environment and livable neighborhoods. 	<p>Yes.</p> <p>This project meets CARA's two key objectives as listed.</p> <p>Additional objectives met:</p> <p>Historic preservation Readily identifiable core Enriching environment</p>
B)	CARA Planned Projects	Which project category and activity in the UR Plan does this project fulfill? (See CARA Project Activities document, or Table 2 of the UR Plan and Report.)	Commercial Building Rehabilitation, Storefront Revitalization
C)	Development Pattern (Highest and Best Use)	Does it achieve desired land use (e.g., mixed-use, higher density) and/or transportation objectives (e.g., Esplanade, pedestrian-friendly areas)? Is the proposed project desired in this location and the highest and best use of the property?	Zone: Historic Downtown Yes, current uses fit within options for highest and best use for this property.
D)	Blight	Would it remedy a severely blighted building? How? Does the project utilize a vacant space?	Property is at risk of becoming blighted if repairs are not completed.

E)	Preservation	Would it rehabilitate or sensitively redevelop a historic property?	Yes.
F)	Vitality/People Attractor	Does the general public benefit (i.e. restaurant, carousel, something they can go to; does the project enhance the public's experience of the space; is it a business we are seeking)?	Project supports space for existing business and upper floor residential use.
G)	Retail Hotspot (First Avenue between Lyon and Calapooia)	Is the project located in the Retail Hotspot? If so, will the first floor use be active retail, as recommended in the Retail Refinement Plan?	Yes. No, first floor is not currently in retail use.
H)	Sustainable Building	Will the building be built using sustainable practices including LEED or others?	Not addressed in application.
I)	Residential	Is there a residential component? How many units?	Yes, existing upper floor residential units are positively impacted by project.
<i>Economic Development</i>			
J)	Bring new business to Albany	Will a new business open or come to Albany as a part of this project?	No.
K)	Job Creation	Will the project create additional jobs? How many, what types and what salary level?	No.
L)	Local Labor and Materials	Has applicant specifically called out a commitment to use a certain percent or amount of local labor and/or materials?	Yes, commitment to use local contractors for this project.
<i>Financial</i>			
M)	Ratio	Proposed public funds Private funds % of CARA Investment	Applicant requesting 75% of total project costs.
N)	Financial Impacts	What are the financial risks and/or financial benefits to CARA?	Reimbursement based-grant; low financial risk. Benefits through increased value.
O)	Gap	What is the "Gap" or need of the developer?	\$9,720
P)	Private Risk	What is the risk for the developer? What is their skin in the game?	\$3,240
Q)	CARA/City funds	Has the project received other CARA/City funding in the past?	No.
R)	Tax Increment ROI	Is the ROI on this project less than 5 years, less than 7 years?	ROI will be achieved through increased property value.



CARA GRANT APPLICATION

1. APPLICANT

Name: Jamie and Eric Howard

Mailing Address: 635 NE Water Ave.

Albany Zip Code: 97321

Title: Member Phone Number: [REDACTED]

E-mail Address: [REDACTED]

2. BUSINESS/BUILDING INFORMATION

Legal Business Name: Albany Steamworks, LLC dba Deluxe Brewing Co. & Sinister Distilling Co.

Number of Years in Operation: 13

Legal Form: Sole Proprietorship Partnership Corporation S-Corp LLC
 Profit Nonprofit

EIN: [REDACTED]

In which state are the incorporation and/or organization documents filed? OR

Have you ever filed for bankruptcy? Yes No

Project Address (if different than mailing address): same

Property Tax Account Number: 84257

Is the building a historic contributing resource? Yes No

If so, is it on the historic property-tax freeze? Yes No

3. OWNER OF PROPERTY (if not applicant)

Name in which title is held: John A. Boock, Jr., as Trustee of The John A. Boock Jr. Revocable Living Trust

Contact Name: John Boock

Mailing Address: [REDACTED]
[REDACTED] Zip Code: [REDACTED]

Phone Number: [REDACTED]

4. AUTHORIZATION TO UNDERTAKE WORK:

If the applicant is not the owner of the property, provide written evidence that the owner authorizes this work to be undertaken. (Typically this is in the form of a lease or other written permission.)

Please see attached

5. DESCRIPTION OF PROJECT *Please give a comprehensive description of project.*

Please see attached.

6. TIMELINE FOR COMPLETION OF PROJECT: April 30, 2027

7. PROJECT COSTS

ESTIMATED COST OF PROJECT: \$ 115,900

ESTIMATED VALUE OF PROJECT UPON COMPLETION: \$ 125,000

Basis for valuation and value upon completion: Basis for valuation is based on the current condition of the property, and the scope of proposed improvements and is an estimated value.

SOURCES FOR PROJECT:

Owner/Company Contribution	\$ _____
Bank (estimated)	\$ <u>30,000</u>
Other private funds (please specify)	\$ _____
Other governmental (please specify)	\$ _____
CARA (proposed)	\$ <u>85,900</u>
TOTAL SOURCES	\$ <u>115,900</u>

Is your funding for these: available today applied for unknown at this time

USES FOR PROJECT:

Land and/or Building Acquisition	\$ _____
Soft Costs (architectural, engineering, financing, and legal fees, and other pre- and post-construction expenses.) *	\$ <u>11,580</u>
Construction Costs *	\$ <u>104,320</u>
Tenant Improvements	\$ _____
Machinery/Equipment/Installation Costs	\$ _____
Working Capital	\$ _____
Other (please specify)	\$ _____
TOTAL USES	\$ <u>115,900</u>

*Please provide a detail of Soft Costs and of Construction Costs.

Soft Costs

Engineering and Permits: \$11,580

Construction Costs

160 Window Pane Replacements: \$32,500

Construction of 2 New Restrooms and Repair 2 Existing Restrooms: \$71,820

- Materials: \$14,322
 - o Lumber: \$2,125
 - o Fire Door: \$4,200
 - o Bathroom Doors: \$840
 - o Knobs, ADA bars and trim: \$2,537
 - o Cadet Heaters: \$420
 - o Insulation: 1,200
 - o Misc: \$3,000

- Subcontractors: \$41,895
 - o Electrician: \$10,500
 - o Plumbing: \$16,590
 - o Concrete Cutter: \$2,730
 - o Drywall: \$6,825
 - o Painters: \$5,250

- Labor (General Contractor): \$4,725
- Overhead & Profit (15%): \$10,878

8. PREPARATION OF COST ESTIMATES

Who prepared your cost estimates? Smith Glass, Davis Glass, Novak Construction, JayB Construction

(If applicant prepared their own estimate, verification may be required. **Please attach minimum of two bids, preferably three.**)

Mailing Address: Please see attached for bids

Phone Number: _____ E-mail Address: _____

9A. EXPLAIN WHY CARA FUNDING IS NECESSARY TO INSURE PROJECT COMPLETION. *(Please provide a description of the financial gap requiring CARA assistance.)*

Please see attached

9B. IF YOU DON'T RECEIVE THE FUNDS, WHAT COMPONENTS WILL BE DROPPED? WOULD THE PROJECT GET DONE WITHOUT CARA FUNDS? *(Please provide a detailed explanation.)*

Please see attached

10. WHERE ELSE HAVE YOU LOOKED FOR FUNDING?

Please see attached

11. CONSIDERING THE PROJECT GOALS OUTLINED IN THIS APPLICATION, PLEASE IDENTIFY THE VALUE YOUR PROJECT BRINGS TO CARA.

Please see attached

12. PLEASE OUTLINE ANY OTHER BENEFITS YOUR PROJECT PROVIDES. (To Albany, and the area/neighborhood)

Please see attached

13. HAVE YOU OR THIS PROPERTY RECEIVED CARA FUNDING AT ANY POINT IN THE PAST?

No Yes If so, amount \$ 4500

FOR WHAT PROJECT(S): To cover half the cost of repairing and painting the exterior of the "tower."

WHEN? March 2014

14. ASSISTANCE REQUESTED

Total Estimated Project Costs:	\$ <u>115,900</u>
Your Total Contribution	\$ <u>30,000</u>
Total Amount Requested from CARA:	\$ <u>85,900</u>

Final payment will be based on actual costs not estimates. **Ten percent of CARA funds will be held back for final payment.**

15. BREAKDOWN OF USE OF CARA FUNDS

CARA funds can only be used for permanent improvements to the building. Please provide a breakout with specific details of how the CARA funds will be used in the project. If more space is needed, please attach a separate page.

Item	Amount	Notes
Replace glass in boarded up windows	\$22,500	This repairs all boarded up windows on the SW end, west end and 2nd floor above brewery.
Install and repair restrooms, one ADA	\$63,400	Two new restrooms will be installed and two more will be repaired.
TOTAL	\$85,900	Total should match total amount requested from CARA from line 14.

Metrics and Other Benefits

If you receive funding, you will be asked to tally the final figures on the project and certify their accuracy. Please use this space to estimate the impact of your project:

Number of Jobs Created: _____ Full-time _____ Part-Time

Certification

The Applicant understands and agrees to the following conditions:

1. Any physical improvements proposed must be approved by the Albany Revitalization Area Agency (ARA) and may require approval by the City of Albany Landmarks Advisory Commission or other entities. These entities may require certain changes or modifications before final approval and Commitment of Funds.
2. Contract will not be processed until the Applicant satisfies all conditions.
3. Any work begun before receipt of a Contract notice is ineligible for reimbursement.
4. Any work deviating from that detailed in the Contract must be preapproved in writing to be eligible for reimbursement.
5. While only proprietary information may be held in confidence outside of the public record, ARA will attempt to maintain all information provided in a confidential manner.
6. Originals of all materials prepared with ARA assistance belong to ARA and will be maintained in the public record.
7. Application must be completed in its entirety before being considered; if not, it will be returned for completion.
8. Staff is authorized to independently verify any and all information contained in this application.
9. ARA may withhold approval of this application until information satisfactory to ARA is provided.

The Applicant certifies that all information in this application and all information furnished in support of this application is given for the purpose of obtaining ARA assistance and is true and complete to the best of the Applicant's knowledge. Applicant further acknowledges the undersigned applicant(s) have read and understand CARA's privacy policy and have completed this form with accurate information.

Jamie Howard
Applicant's Printed Name

Eric Howard
Applicant's Printed Name

Applicant's Signature 

Date 3-10-2026

Applicant's Signature 

Date 3-10-2026

Return application/attachments to: City of Albany c/o Sophie Adams, Economic Development Manager: Sophie.adams@albanyoregon.gov

CARA Grant Application

Applicant: Eric & Jamie Howard, Albany Steamworks, LLC dba Deluxe Brewing & Sinister Distilling

Responses to Questions 5, 9A, 9B, 10, 11, 12

Question 5 - Description of Project

This project involves the renovation and accessibility improvements to the commercial building located at 635 NE Water Ave. where Deluxe Brewing is located. The goal of the project is to improve accessibility, enhance the building's functionality, and contribute to the continued revitalization and visual improvement of the surrounding area in Albany.

A primary component of the project is the construction of two new restroom facilities and the repairs of two existing bathrooms located within the building. One of these restrooms will be designed and constructed to meet ADA accessibility standards, ensuring that individuals with disabilities have equal access to the building's amenities. This accessible restroom will include appropriate maneuvering clearances, ADA-compliant fixtures, grab bars, accessible sink, and doorways designed to meet current accessibility and building code requirements.

The addition of these restrooms will significantly improve the building's ability to accommodate customers, and visitors, making the space more functional and inclusive.

Another key component of the project is the removal of existing boarded window coverings and the restoration of the building's window openings. Currently, all the windows on the southwest end of the building are boarded, which detracts from the building's exterior appearance and the windows on the second floor of the brewery are all removed. This project will remove the boarded materials and install new windows or restore the existing openings.

Restoring the windows will enhance the building's presence along NE Water Avenue and contribute positively to the surrounding streetscape. Improved building visibility and aesthetics support ongoing efforts to create a more welcoming and vibrant space. Addressing these issues is essential to improving the functionality, safety, and visual appeal of the property while supporting broader community revitalization efforts.

Community Benefit

This project will provide several important benefits to the community:

- **Improved Accessibility:** The addition of ADA-compliant restroom will ensure that individuals with disabilities can comfortably access and utilize the building.

- **Enhanced Visitor Experience:** Additional restroom facilities will better support Deluxe Brewing and the customers they serve.
- **Downtown Revitalization:** Removing boarded windows and restoring the building's façade will improve the streetscape and contribute to the ongoing revitalization of the surrounding area.
- **Economic Vitality:** Improvements to the building will make the space more attractive, supporting local economic activity and business development.

Overall, these upgrades will help transform the building into a more welcoming, functional, and accessible space that contributes positively to the community.

9A. Explain Why CARA Funding is Necessary to Insure Project Completion.

CARA funding is essential to ensure the successful completion of the planned building improvements. While we are committed to investing significant funds into the renovation, the total cost of the project exceeds the available budget. Construction costs associated with accessibility improvements, new restroom facilities, structural modifications, and window restoration have created a financial gap that makes it difficult to complete all planned improvements without additional support.

Without this assistance, the scope of the project may need to be reduced or delayed, limiting the ability to fully address accessibility needs and complete the exterior improvements that contribute to the revitalization of the surrounding commercial area.

By providing this support, CARA funding will allow the project to move forward as planned, ensuring that the building improvements, including ADA accessibility upgrades and façade restoration—are completed in a timely manner. These improvements will enhance the usability of the building while also contributing to the ongoing economic vitality and visual improvement of the surrounding Waterfront area.

9B. If we don't receive the funds, what components will be dropped?

Without CARA assistance, the project would likely proceed in a limited or phased manner, focusing first on essential interior work while delaying some accessibility and façade improvements. This would reduce the immediate impact of the project on both accessibility and the visual improvement of the building.

CARA funding would allow the project to move forward as originally planned, ensuring that accessibility improvements and exterior enhancements are completed at the same time. This coordinated approach maximizes the benefit of the investment by improving building functionality, accessibility, and the overall appearance of the property, while also contributing to the ongoing revitalization of the surrounding area in Albany.

10. Other Funding Sources Explored

In preparation for the improvements to the building, we have explored several potential funding sources to help support the cost of the project. These efforts included reviewing traditional financing options.

Discussions were held with local financial institutions regarding potential loan financing to support the renovation work. However, due to the increasing costs associated with construction, accessibility upgrades, plumbing installation, and building improvements, loan financing alone would significantly increase the financial burden of the project.

As a result, funding assistance through CARA represents one of the most appropriate and impactful opportunities to help bridge the remaining financial gap. CARA funding was designed to support projects that improve building accessibility, functionality, and appearance within the revitalization area, making it well aligned with the goals and scope of this project.

Assistance through CARA will help ensure that the full scope of improvements, particularly accessibility upgrades and façade restoration can be completed as planned and without significant delay.

11. The Value of the Project to CARA

The proposed improvements to our building align closely with the goals CARA, which seeks to strengthen the vitality, accessibility, and visual appeal of properties within the district.

This project contributes value to CARA in several key ways.

Accessibility Improvements:

The addition of an ADA-compliant restroom will significantly improve accessibility within the building, ensuring that individuals with disabilities can comfortably access and use the facility. Expanding accessibility supports a more inclusive business environment and aligns with CARA's goals of creating welcoming spaces for all residents and visitors.

Building Revitalization and Appearance:

The removal of boarded windows and restoration of the building's window openings will improve the exterior appearance of the structure and enhance the overall streetscape along NE Water Avenue.

Support for Local Business Activity:

Upgraded restroom facilities and improved building conditions will make our brewery more functional within the space. Improved infrastructure supports our current business operations and increases the building's future potential.

Supporting Other Local Businesses:

All our bids came from local businesses. Using local contractors strengthens the regional economy by keeping grant funds circulating within the community and supporting small businesses.

Energy Efficiency:

Replacing boarded or missing windows with properly installed windows will significantly reduce air leakage, improve insulation, and help maintain consistent indoor temperatures. This upgrade lowers heating and cooling costs, and contributes to long-term energy savings and building sustainability.

Encouragement of Private Investment:

This project represents a meaningful investment in the improvement and long-term viability of the building. CARA funding will ensure the full scope of improvements can be completed.

Long-Term Community Impact:

Together, these improvements will create a more accessible, functional, and visually appealing building that supports the broader revitalization goals of Albany. The project strengthens and enhances the experience for customers and contributes to a more active and welcoming commercial area.

Through accessibility improvements and façade restoration this project delivers lasting value that directly supports CARA's mission of improving and revitalizing properties within the Central Albany Revitalization Area.

12. Additional Benefits to the Community and Neighborhood

The proposed improvements provide several additional benefits that extend beyond the property itself and positively impact the surrounding neighborhood and the broader community.

Improved Neighborhood Appearance

Removing the boarded windows and restoring the building's façade will significantly improve the visual character of the property. Buildings with active windows and improved exterior features create a more welcoming and attractive streetscape, contributing to the overall appearance and perception of the surrounding area.

Increased Pedestrian Activity

Enhancing the building's functionality and appearance encourages greater use of the property by customers. Increased activity helps create a more vibrant and active environment and encourages pedestrian traffic throughout the district.

Support for Small Business

Upgraded infrastructure, including additional restroom facilities and ADA accessibility improvements, helps ensure the building can better support our customers.

Safer and More Welcoming Environment

Removing boarded windows and restoring transparency contribute to a safer and more welcoming environment for residents and visitors.

Long-Term Investment

This project represents a long-term investment in maintaining and improving an existing commercial structure within the community. Improvements that upgrade accessibility, functionality, and appearance help ensure the building remains an active and productive part of the neighborhood for years to come.

Collectively, these benefits support the continued growth, accessibility, and vibrancy of the area while reinforcing ongoing revitalization efforts within the Central Albany district.

Property Address:
635 NE Water Ave.
Albany, OR 97321

Property Owner: John Boock
Tenant/Business: Albany Steamworks LLC

Date: March 26, 2026

To Whom It May Concern:

I, John Boock, am the legal owner of the property located at 635 NE Water Ave., Albany, OR 97321. I hereby grant authorization to Albany Steamworks LLC, as tenant of the above-referenced property, to perform and complete improvements and construction work within the building.

This authorization includes, but is not limited to:

- Construction of two restroom facilities, including one ADA-compliant restroom
- Plumbing, electrical, and structural improvements related to restroom installation
- Removal of boarded windows and installation or restoration of windows
- Interior tenant improvements and renovations
- Application for permits and coordination of inspections
- Completion of related improvements necessary for building functionality and accessibility

This authorization allows Albany Steamworks LLC to work with contractors, engineers, architects, and the City of Albany to complete the above-described improvements in compliance with all applicable codes and regulations.

This authorization shall remain in effect for the duration of the project unless revoked in writing by the property owner.

Property Owner Information:

Name: John Boock

Signature: _____

Date: 3/27/26

Tenant Information:

Business Name: Albany Steamworks LLC

Authorized Representative: Jamie Howard, Managing Member

Signature: _____

Date: 3/27/26

SMITH GLASS SERVICE, INC.
133 N. LYON STREET
Albany, OR 97321

635 NE Water Ave

Contractor License: 43663
Federal Tax ID: 930840788

P/O#: [REDACTED] Cust State Tax ID: [REDACTED] **Quote: Q1021119**
Cust Fed Tax ID: [REDACTED] **Date: 3/5/2026**
Taken By: Darryl Ship Via: [REDACTED]
Installer: [REDACTED] Adv. Code: [REDACTED]
SalesRep: SP

Bill To: 1ONE A

Sold To: 1ONE A

Deluxe Brewing
635 NE Water AVE
Suite B
ALBANY, OR 97321

Eric Howard

Qty	Part Number	Description	List	Disc%	Sell	Total
160	MISC ALB RESID	Budgetary Pricing: Replace glass in metal frames, includes glass, glazing, and labor per window opening.	\$170.00	0	\$170.00	\$27,200.00

Email: [REDACTED]
PRICING INCLUDES INSTALLATION.

PRICING ON QUOTES IS GOOD FOR 30 DAYS.

TERMS: 50% DEPOSIT REQUIRED TO START YOUR ORDER AND BALANCE DUE UPON COMPLETION

Jobsite walk through showed numerous missing or broken.
Hazardous material testing and abatement (if required) by others.

UPON RECEIPT

Sub Total: \$27,200.00

Total: \$27,200.00

**DAVIS GLASS INC
230 2ND AVE SE
ALBANY OR 97321**

635 NE Water Ave

Tax# 93-0654560

Quote: 29067

Date:03/24/2026

Customer

DELUXE BREWING CO SINISTER DISTILLING
CO
635 WATER ST
ALBANY OR 97321

Cell:(541)905-7756

Csr:GEOFF Tech: PO Terms:C.O.D

<u>Qty</u>	<u>Part / Description</u>	<u>Item Total</u>
1	MISC GENERAL - REPLACE & GLAZE 1/8" CLEAR GLASS IN STEEL SASH	32,500.00

Notes: ESTIMATE TO PROVIDE AND REGLAZE 160 MISC PIECES OF 1/8" CLEAR GLASS THROUGHOUT THE BUILDING. EXISTING STEEL SASHES HAVE SOME SECTIONS MISSING AND WILL NEED TO BE DEALT WITH ON AN INDIVIDUAL BASIS. PROJECT SCOPE INCLUDES THE FOLLOWING: REMOVE EXISTING STEEL SASH PUTTY AND REGLAZE THE REQUIRED PANES OF MISSING OR BROKEN GLASS. ANY AND ALL TOUCH UP PAINTING IS BY OTHERS. RUSTED FRAMES ARE A CONCERN WITH ADHESION OF THE STEEL SASH PUTTY MOVING FORWARD. THIS IS A CAUTION I HAVE AND SHOULD BE DISCUSSED PRIOR TO MOVING FORWARD. THANK YOU! DAVIS GLASS INC

Signature _____
**Please note pricing is subject to change

<u>Tax</u>	<u>Total</u>	<u>Payments</u>	<u>Balance</u>
0.00	32,500.00	0.00	32,500.00

ESTIMATE

Jay B Construction, Inc.
PO Box 2511
Corvallis, OR 97339-2511

**Bill to**

Eric & Jamie Howard
Deluxe Brewing, LLC
635 Water St. Suite B
Albany, OR

Ship to

Eric & Jamie Howard
Deluxe Brewing, LLC
635 Water St. Suite B
Albany, OR

Estimate details

Estimate no.: 1188
Estimate date: 03/20/2026

P.O. Number: Public restroom addition
Sales Rep: JB

#	Date	Product or service	Description	Qty	Rate	Amount
1.			Proposal to add 2 public restrooms inside existing structure. This bid assumes the existing waste lines in the floor can be used and no concrete cutting or sub slab plumbing work will be required.			
2.		Plans/Permits/Engineering	Allowance for permits, floor plans and engineering	1	\$10,000.00	\$10,000.00
3.		1300 - Demolition	Cut in new door opening in existing block wall Demo drywall/plaster/wall board/tile/ceiling in proposed space.	1	\$4,980.00	\$4,980.00
4.		3250 - Framing	-Install new header support in block wall per engineering requirements. -Frame in new hallway, bathrooms w/ steel framing.	1	\$3,920.00	\$3,920.00
5.		3730 - Plumbing	Allowance for rough plumbing, fixtures and install.	1	\$18,000.00	\$18,000.00
6.		3820 - Electrical	Rough in and install new lights/switches, power for local tankless water heaters	1	\$13,600.00	\$13,600.00
7.		5750 - HVAC	Venting for bath fans	1	\$1,200.00	\$1,200.00
8.		3580 - Fire Suppression Systems	Allowance for fire suppression work(if required)	1	\$2,500.00	\$2,500.00

9.	4400 - Insulation	Insulate new bathroom walls	1	\$800.00	\$800.00
10.	5100 - Drywall	5/8" drywall smooth	1	\$2,400.00	\$2,400.00
11.	5300 - Painting—interior	Prime/paint new walls and existing areas	1	\$1,800.00	\$1,800.00
12.	5580 - Wainscoting	Allowance for tile wainscot in bathrooms 4' *Option for FRP \$2,200	1	\$3,680.00	\$3,680.00
13.	Acoustical Ceilings	New acoustical ceiling in hall	1	\$900.00	\$900.00
14.	4310 - Interior Doors	1)3hr timely fire door 2)timely steel doors Hardware Installed	1	\$3,620.00	\$3,620.00
15.	5520 - Special flooring	Grind/seal existing concrete floor	1	\$1,180.00	\$1,180.00
	Subtotal	Subtotal			\$68,580.00
16.	Contractor Fee	Overhead, Supervision, Coordination(22%) *Negotiable	1	\$15,088.00	\$15,088.00
17.	Services	Oregon Corporate Activity Tax			\$192.20
		Total			\$83,860.20

Note to customer

Thank you for the opportunity to bid this project.

Accepted date

Accepted by



34261 Cricket Ln NE
Albany, OR 97322

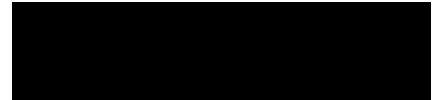

ESTIMATE

Project: Bathroom Construction at Deluxe Brewing, 635 NE Water Ave., Albany, OR 97321

Date: March 17, 2026

1. Scope of Work

- **Demolition:** Remove existing cabinets and non-structural walls.
- **Structural:** Build two separate bathrooms, one ADA compliant and 1 standard
- **Electrical:** Install lights, bathroom fans and dedicated circuits
- **Plumbing:** Install toilets and sinks and tie into existing plumbing
- **Hot Water Heater:** Install cadet heaters and hot water heater
- **ADA Compliance:** Install ADA knobs, bars and handles
- **Finishes:** Install insulation and paint walls/ceiling

2. Detailed Cost Breakdown (Estimate)

- **Materials:** \$14,322
 - *Lumber:* \$2,125
 - *Fire Door:* \$4,200
 - *Bathroom Doors:* \$840
 - *Knobs, ADA bars and trim:* \$2,537
 - *Cadet Heaters:* \$420
 - *Insulation:* 1,200
 - *Misc:* \$3,000

- **Subcontractors: \$43,476**
 - *Electrician: \$10,500*
 - *Plumbing: \$16,590*
 - *Concrete Cutter: \$2,730*
 - *Drywall: \$6,825*
 - *Engineering: \$1,581*
 - *Painters: \$5,250*
- **Labor (General Contractor): \$4,725**
- **Permits & Fees: \$10,000**
- **Overhead & Profit (15%): \$10,878**
- **Total Project Bid: \$83,401**

3. Exclusions (What is NOT included)

- *Hidden structural repairs.*
- *Asbestos removal.*

4. Project Timeline

- **Estimated Completion:** March 30, 2027

5. Payment Schedule

- **Deposit (10%): \$8,340**
- **Progress Payment (50% - Upon demolition/rough-in completion): \$41,700.50**
- **Final Payment (40% - Upon substantial completion/inspection): \$33,360.50**

6. Terms and Conditions

- This proposal is valid for 30 days.
- Change orders must be signed by both parties.
- Warranty: 1 year on labor and workmanship.

Accepted By

Name _____ **Date** _____



635 NE Water Ave



635 NE Water Ave

**DELUXE**
BREWING CO.
NEXT LEFT

A





Project Evaluation Grid: 635 NE Water Avenue

Request: \$85,900

	Item	Description	Staff Analysis/Comments
<i>Overall Goals</i>			
A)	<p>CARA Goal & Objectives: The purpose of this CARA Plan is to eliminate blighting influences found in the CARA, to implement goals and objectives of the City of Albany Comprehensive Plan, and to implement development strategies and objectives for the CARA. The goal and objectives for the CARA have been defined as follows:</p> <p>CARA Goal: To revitalize the Central Albany Revitalization Area by implementing the Town Center Plan developed through the Central Albany Land Use & Transportation Study (CALUTS) using a citizen-driven process.</p>	<p>Does the project further the Town Center Plan?</p> <p>Which of CARA’s objectives does the project meet?</p> <p>CARA Key Objectives:</p> <ul style="list-style-type: none"> ◆ Attract new private investment to the area. ◆ Retain and enhance the value of existing private investment and public investment in the area. <p>CARA Additional Objectives:</p> <ul style="list-style-type: none"> ◆ Provide a safe and convenient transportation network that encourages pedestrian & bicycle access to and within the town center. ◆ Preserve the Historic Districts, historic resources and existing housing in the area. ◆ Create a readily identifiable core that is unique and vibrant with a mixture of entertainment, housing, specialty shops, offices, and other commercial uses. ◆ Increase residential density in the area. ◆ Encourage the development of new forms of housing and home ownership. ◆ Enhance and protect the community and environmental values of waterway corridors in the area. ◆ Provide an enriching environment and livable neighborhoods. 	<p>Yes.</p> <p>This project meets CARA's two key objectives as listed.</p> <p>Addition objectives met:</p> <p>Historic preservation Readily identifiable core Enriching environment</p>
B)	<p>CARA Planned Projects</p>	<p>Which project category and activity in the UR Plan does this project fulfill? (See CARA Project Activities document, or Table 2 of the UR Plan and Report.)</p>	<p>Commercial Building Rehabilitation, Transition Areas Development</p>
C)	<p>Development Pattern (Highest and Best Use)</p>	<p>Does it achieve desired land use (e.g., mixed-use, higher density) and/or transportation objectives (e.g., Esplanade, pedestrian-friendly areas)? Is the proposed project desired in this location and the highest and best use of the property?</p>	<p>Zone: Waterfront District</p> <p>Yes, current business fits within options for highest and best use for this property.</p>
D)	<p>Blight</p>	<p>Would it remedy a severely blighted building? How? Does the project utilize a vacant space?</p>	<p>No.</p>

E)	Preservation	Would it rehabilitate or sensitively redevelop a historic property?	Yes.
F)	Vitality/People Attractor	Does the general public benefit (i.e. restaurant, carousel, something they can go to; does the project enhance the public's experience of the space; is it a business we are seeking)?	Yes, supports existing business and event space.
G)	Retail Hotspot (First Avenue between Lyon and Calapooia)	Is the project located in the Retail Hotspot? If so, will the first floor use be active retail, as recommended in the Retail Refinement Plan?	No.
H)	Sustainable Building	Will the building be built using sustainable practices including LEED or others?	Not addressed in application.
I)	Residential	Is there a residential component? How many units?	No.
<i>Economic Development</i>			
J)	Bring new business to Albany	Will a new business open or come to Albany as a part of this project?	No.
K)	Job Creation	Will the project create additional jobs? How many, what types and what salary level?	No.
L)	Local Labor and Materials	Has applicant specifically called out a commitment to use a certain percent or amount of local labor and/or materials?	Yes, commitment to use local contractors for this project.
<i>Financial</i>			
M)	Ratio	Proposed public funds Private funds % of CARA Investment	Applicant requesting 74% of total project costs.
N)	Financial Impacts	What are the financial risks and/or financial benefits to CARA?	Reimbursement based-grant; low financial risk. Benefits through increased value.
O)	Gap	What is the "Gap" or need of the developer?	\$85,900
P)	Private Risk	What is the risk for the developer? What is their skin in the game?	\$30,000
Q)	CARA/City funds	Has the project received other CARA/City funding in the past?	Yes.
R)	Tax Increment ROI	Is the ROI on this project less than 5 years, less than 7 years?	ROI will be achieved through increased property value.



CARA GRANT APPLICATION

1. APPLICANT

Name: Jim MacDonald Properties LLC

Mailing Address: [REDACTED]

[REDACTED] Zip Code: [REDACTED]

Title: [REDACTED] Phone Number: [REDACTED]

E-mail Address: [REDACTED]

2. BUSINESS/BUILDING INFORMATION

Legal Business Name: Jim MacDonald Properties LLC

Number of Years in Operation: 7 years

Legal Form: Sole Proprietorship Partnership Corporation S-Corp LLC

Profit Nonprofit

EIN: [REDACTED]

In which state are the incorporation and/or organization documents filed? OR

Have you ever filed for bankruptcy? Yes No

Project Address (if different than mailing address): 975 Ellsworth SW, Albany, OR 97321

Property Tax Account Number: 92755

Is the building a historic contributing resource? Yes No

If so, is it on the historic property-tax freeze? Yes No

3. OWNER OF PROPERTY (if not applicant)

Name in which title is held: Jim MacDonald Properties LLC

Contact Name: Diana Debray

Mailing Address: [REDACTED]

[REDACTED] Zip Code: [REDACTED]

Phone Number: [REDACTED]

4. AUTHORIZATION TO UNDERTAKE WORK:

If the applicant is not the owner of the property, provide written evidence that the owner authorizes this work to be undertaken. (Typically this is in the form of a lease or other written permission.)

5. DESCRIPTION OF PROJECT *Please give a comprehensive description of project.*

The proposed project is the rehabilitation and code-compliant redevelopment of a long-standing commercial building in Albany, Oregon, to support its transition into a community-serving retail space operated and leased by Furniture Share, a local nonprofit organization. The building has historically operated as a radiator repair shop for several decades. Although it was rezoned for retail use approximately 20 years ago, the previous use continued under a grandfathered status. Upon transfer of ownership to the original owner's heirs, the property became subject to its current retail zoning designation. After a lengthy period of vacancy and limited viable tenancy options, Furniture Share entered into a five-year lease agreement to repurpose the building as a thrift store that directly supports its charitable mission. Prior to occupancy, Furniture Share worked with the City of Albany Planning Department and received confirmation that a thrift store was an appropriate and supported use for the location. However, during the permitting process, it was discovered that a formal change-of-use permit had not been completed to transition the building into compliant retail use under current code requirements. As a result, the project now requires substantial upgrades to meet building and safety codes for retail occupancy. Required improvements include, but are not limited to: ~~Construction of an ADA-compliant restroom, Interior framing, insulation, and wall finishing, Electrical system~~ upgrades, and Required permitting and inspections.

6. TIMELINE FOR COMPLETION OF PROJECT: 04/30/2027

7. PROJECT COSTS

ESTIMATED COST OF PROJECT: \$ 100,000.00

ESTIMATED VALUE OF PROJECT UPON COMPLETION: \$ 275,000.00

Basis for valuation and value upon completion: The estimated value upon completion is \$275,000, based on total project investment, the building's transition to a fully code-compliant retail space, and its increased marketability and income potential with a secured long-term tenant.

Bids from contractors

SOURCES FOR PROJECT:

Owner/Company Contribution	<u>\$ 25,000.00</u>
Bank (estimated)	<u>\$0</u>
Other private funds (please specify)	<u>\$0</u>
Other governmental (please specify)	<u>\$0</u>
CARA (proposed)	<u>\$ 75,000.00</u>
TOTAL SOURCES	<u>\$ 100,000.00</u>

Is your funding for these: available today applied for unknown at this time

USES FOR PROJECT:

Land and/or Building Acquisition	<u>\$0</u>
Soft Costs (architectural, engineering, financing, and legal fees, and other pre- and post-construction expenses.) *	<u>\$ 15,700.00</u>
Construction Costs *	<u>\$ 68,550.00</u>
Tenant Improvements	<u>\$</u>
Machinery/Equipment/Installation Costs	<u>\$ 15,750.00</u>
Working Capital	<u>\$</u>
Other (please specify)	<u>\$</u>
TOTAL USES	<u>\$ 100,000.00</u>

*Please provide a detail of Soft Costs and of Construction Costs (Please attach).

8. PREPARATION OF COST ESTIMATES

Who prepared your cost estimates? See attached Estimates for Contact Information.

(If applicant prepared their own estimate, verification may be required. **Please attach minimum of two bids, preferably three.**)

Mailing Address: _____

Phone Number: _____ E-mail Address: _____

9A. EXPLAIN WHY CARA FUNDING IS NECESSARY TO INSURE PROJECT COMPLETION.

(Please provide a description of the financial gap requiring CARA assistance.)

CARA funding is essential to ensure the completion of this project due to an unexpected and significant financial gap created during the final stages of project readiness. After investing more than \$65,000 in good-faith improvements, staffing, and infrastructure. Furniture Share was informed during permitting that a formal change-of-use approval had not been completed, triggering additional building code requirements for retail occupancy. Prior to occupancy, Furniture Share worked with the City of Albany Planning Department and received confirmation that a thrift store was an appropriate and supported use for the location. However, during the permitting process, it was discovered that a formal change-of-use permit had not been completed to transition the building into compliant retail use under current code requirements. These newly identified requirements including construction of an ADA-compliant restroom, interior framing and insulation, electrical upgrades, and full permitting have added approximately \$100,000 in unanticipated costs. Many of the improvements already completed must now be modified or removed to meet current code, compounding the financial burden. The new owner inherited the building and do not have these kinds of funds available. As a nonprofit organization, Furniture Share operates with limited capital reserves and relies on grants, donations, and program revenue to sustain its services. The organization has already stretched its financial capacity to prepare the building for opening and cannot absorb these additional costs without jeopardizing its core programs, which serve individuals and families experiencing furniture poverty and food insecurity. Without CARA funding, the project will be delayed indefinitely, leaving the building underutilized and preventing the launch of a revenue-generating thrift store that supports critical community services. CARA investment will bridge this financial gap, ensuring the building can be brought into compliance and allowing Furniture Share to open, serve the community, and contribute to local economic revitalization.

9B. IF YOU DON'T RECEIVE THE FUNDS, WHAT COMPONENTS WILL BE DROPPED? WOULD THE PROJECT GET DONE WITHOUT CARA FUNDS? (Please provide a detailed explanation.)

Without CARA funding, the project cannot proceed. The required code-compliance improvements, totaling approximately \$100,000, are essential for occupancy and cannot be reduced or phased. The property owners are only able to meet the required \$25,000 investment and do not have additional resources to cover the remaining costs. Furniture Share has already invested over \$65,000 in good-faith improvements and pre-opening expenses and does not have the financial capacity to absorb further unexpected costs. Without CARA support, no portion of the required upgrades can be completed, and the project will remain unfinished, leaving the building underutilized and unable to serve the community.

10. WHERE ELSE HAVE YOU LOOKED FOR FUNDING?

The building owners will fully commit the required \$25,000 toward improvements and construction, leaving no additional resources available. Furniture Share has researched and reached out to numerous grant opportunities; however, because they do not own the building, they are ineligible for many traditional grants. Despite these efforts, no alternative funding sources have been identified that can cover the substantial cost of bringing the building into full code compliance. CARA funding is therefore critical to bridging this financial gap and ensuring the project's successful completion.

11. CONSIDERING THE PROJECT GOALS OUTLINED IN THIS APPLICATION, PLEASE IDENTIFY THE VALUE YOUR PROJECT BRINGS TO CARA.

This project directly supports CARA's goals of revitalizing underutilized properties, promoting economic development, and enhancing community well-being. By bringing a long-vacant, nonconforming commercial building into full code compliance, the project activates a key property in Albany, improving the safety, appearance, and functionality of the area. The tenant, Furniture Share, is a nonprofit organization whose mission provides broad social, environmental, and economic benefits. The thrift store will generate revenue to fund programs serving individuals and families experiencing furniture poverty and food insecurity. It will also provide volunteer work experience to help job seekers learn valuable job skills, improving their opportunity for gainful employment. The project promotes sustainability through landfill diversion, keeping gently used furniture and household items in circulation, while providing affordable options to families who do not qualify for direct Furniture Share services. By expanding its reach, Furniture Share will serve more families in need, enhancing local quality of life and supporting long-term community stability. Investing CARA funds leverages existing improvements, revitalizes an underutilized property, and generates lasting social, economic, and environmental impact, making this project a strong, sustainable investment in Albany's future.

12. PLEASE OUTLINE ANY OTHER BENEFITS YOUR PROJECT PROVIDES.

(To Albany, and the area/neighborhood)

In addition to its mission-driven impact, this project will enhance neighborhood vitality by activating a previously vacant building, reducing blight, and improving the overall aesthetic of the area. It supports local infrastructure by ensuring a safe, code-compliant space for public use. The project encourages community engagement by hosting events, donation drives, and educational opportunities about sustainability and reuse. It also strengthens partnerships with local organizations, fostering collaboration and shared resources. Overall, the project contributes to a safer, more vibrant, and connected neighborhood, benefiting both residents and the broader Albany community.

13. HAVE YOU OR THIS PROPERTY RECEIVED CARA FUNDING AT ANY POINT IN THE PAST?

No Yes If so, amount \$ _____

FOR WHAT PROJECT(S): _____

WHEN? _____

14. ASSISTANCE REQUESTED

Total Estimated Project Costs:	\$ <u>100,000.00</u>
Your Total Contribution	\$ <u>25,000.00</u>
Total Amount Requested from CARA:	\$ <u>75,000.00</u>

Final payment will be based on actual costs not estimates. **Ten percent of CARA funds will be held back for final payment.**

15. BREAKDOWN OF USE OF CARA FUNDS

CARA funds can only be used for permanent improvements to the building. Please provide a breakout with specific details of how the CARA funds will be used in the project. If more space is needed, please attach a separate page.

Item	Amount	Notes
Permits	10,700.00	Permits for building code
Heat and AC	10,750.00	
Const new walls	10,350.00	For building code compliance
Electrical work	9,250.00	For building code compliance
Insulation	13,700.00	For building code compliance
Prime/paint	8,750.00	Repainting new walls
Demo/rebuild bathroom ADA	11,500.00	For building code compliance
TOTAL	\$75,000.00	Total should match total amount requested from CARA from line 14.

Metrics and Other Benefits

If you receive funding, you will be asked to tally the final figures on the project and certify their accuracy. Please use this space to estimate the impact of your project:

Number of Jobs Created: 1 Full-time 2 Part-Time

Certification

The Applicant understands and agrees to the following conditions:

1. Any physical improvements proposed must be approved by the Albany Revitalization Area Agency (ARA) and may require approval by the City of Albany Landmarks Advisory Commission or other entities. These entities may require certain changes or modifications before final approval and Commitment of Funds.
2. Any work begun before receipt of a Contract notice is ineligible for reimbursement.
3. Any work deviating from that detailed in the Contract must be preapproved in writing to be eligible for reimbursement.
4. While only proprietary information may be held in confidence outside of the public record, ARA will attempt to maintain all information provided in a confidential manner.
5. Originals of all materials prepared with ARA assistance belong to ARA and will be maintained in the public record.
6. Application must be completed in its entirety before being considered; if not, it will be returned for completion.
7. Staff is authorized to independently verify any and all information contained in this application.
8. ARA may withhold approval of this application until information satisfactory to ARA is provided.

The Applicant certifies that all information in this application and all information furnished in support of this application is given for the purpose of obtaining ARA assistance and is true and complete to the best of the Applicant’s knowledge. Applicant further acknowledges the undersigned applicant(s) have read and understand CARA’s privacy policy and have completed this form with accurate information.

Jim MacDonald Properties LLC

Diana Debray

Applicant’s Printed Name

Applicant’s Printed Name

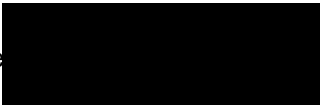
Applicant’s Signature 

Date 3/26/36

Applicant’s Signature _____

Date _____

Return application/attachments to: City of Albany c/o Sophie Adams, Economic Development Manager: sophie.adams@albanyoregon.gov

Proposal 49-1

Issue Date March 26, 2026

Expires April 10, 2026



PREPARED BY

Henry Ryals
Ryals Design Build, LLC



935 NW Jones Ave, Albany, OR 97321, USA

PREPARED FOR

Michelle Maddux-Robinson
Michelle Maddux-Robinson

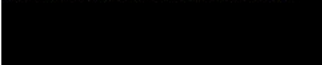

975 SW Ellsworth St, Albany, OR 97321, USA

PROPOSAL DETAILS

Furniture Share

975 SW Ellsworth St, Albany, OR 97321, USA

Estimate for Interior Remodeling Work. Scope includes Insulating wall & ceiling cavities, Gypsum Wallboard covering of interior partitions taped & textured to level 3 & painted with two coats interior latex paint. Installation of electrical rough wiring and fixtures, Selective demo and re-framing of bathroom. Rough and finish plumbing necessary to complete bathroom, Wall-mounted sink and ADA-compliant faucet, Mirror, bathroom hardware, LVP Flooring in bathroom, Cove Base and interior door with ADA-Compliant privacy lever handle set, Bathroom vent fan. Haul-off of all resultant construction debris. **Price subject to change pending final design, fixture & finish selections. Design work not included**

DESCRIPTION

Permits

General Commercial Permit

Portable Toilet

Monthly Rental, Weekly Service

Waste Disposal

Per Load

Interior Partition Selective Demo

Remove existing partitions. Full temp protection and clean up. Non load-bearing

Interior Wall Framing

2x4 or 2x6 (plumbing wall), 16 oc, All blocking & backing

Complete Bathroom Plumbing

Rough plumbing on a per bathroom basis. No Fixtures Included

Electrical Wiring

Electrical wiring, receptacles switches, can lights. Up to 10 120v Outlets, 24 LED Lights, Bathroom fan & light, HWH wiring

R15 Batt Insulation

Kraft Faced Fiberglass

R30 Batt Insulation

Fiberglass batts, interior vapor control layer

R8 Rigid insulation

XPS Foam insulation on garage doors

Drywall

5/8" Gypsum Wallboard. Walls & Ceilings. Materials & Labor. Level 3, Orange-Peel texture, Primed

Interior Paint

Square foot of Walls, ceilings, Doors, Trim. Primed, Caulked, Puttied, Painted

Water Closet

American Standard, Delta, etc. Elongated Bowl. Floor Mounted

Lavatory Basin (\$220.00)
Undermount, Vitreous

Lavatory Faucet (\$200.00)
Moen, Delta, etc.

LVT & Laminate Flooring
Floating Floor Install, No trim, no demo. \$2.00 per square foot material allowance

FRP Wall Paneling
48" AFF on all bathroom interior walls

Bathroom Hardware
ADA Grab Bars for Water Closet, Recessed Bobrick Paper towel dispenser waste receptacle combo, Bathroom mirror.

Fan
Bathroom Vent Fan, \$200 Fixture and Control Allowance

TOTAL \$81,833.46

This proposal is an estimate and is for budgeting purposes only. This does not constitute a binding bid. Price subject to change pending final design, fixture & finish selections.

1. Parties and Agreement

Prime construction contract between Ryals Design Build, LLC, and the individual or organization listed in the "Prepared For" heading of this document, hereinafter referred to as "Client".

Ryals Design Build, LLC is a licensed construction contractor with the Oregon Construction Contractors Board and has a valid license and bond at the time of this contract's signing.
The following information is recorded by the CCB:
Real & True Name: Ryals Design Build, LLC
CCB number: 242145
Address: 935 NW Jones Ave. Albany, OR, 97321
Phone: 541-602-9211

Ryals Design Build will carry throughout the duration of the project Liability Insurance in the following amounts. This does not cover Design Errors & Omissions.
\$2,000,000 General Aggregate
\$2,000,000 Products/Completed Ops Aggregate
\$1,000,000 Personal & Advertising Injury
\$1,000,000 Each Occurrence

Ryals Design Build, LLC will also carry throughout the duration of the project workers compensation insurance for all employees in accordance with the requirements of the State of Oregon.

The Parties hereby agree to the following:

2. Scope of Work :

Ryals Design Build shall complete the scope of work as outlined in the "Description" section above to the schedule outlined below.

Any changes made to the Scope of Work or the Drawings & Specifications after signing of this contract will result in a written Change Order which carries an origination fee of \$400, regardless of the financial impact of said Change Order. Change orders to be billed on a fixed price basis or \$100 per man-hour plus materials.

3. Project Schedule

Ryals Design Build, LLC shall commence with the work on TBD and proceed with earnest to substantial completion on TBD. Throughout the duration of the project Ryals Design Build, LLC shall have open and unobstructed access to the job site. If the work is on or in an occupied structure then working hours will be between 7:00 AM and 3:00 PM on days M T W T F except for federal holidays. If incidents outside Ryals Design Build, LLC's control cause delays to the project including, but not limited to: Client's failure to make material selections by their due date, Client's failure to comply with the payment schedule, Client restricting or not maintaining access

to the jobsite beyond the agreed-to times in the contract, change orders which in any way add to or delay labor, design, permitting, or materials lead-time, severe weather events, theft or vandalism, terrorism, labor strikes, etc. then an amount of time equal to the delay will be added to the substantial completion date.

4. Quality Standards

All work will conform to industry standards in the area in which the work is to be performed. If Client has questions or concerns regarding work, they are to contact their project manager directly and set a time to review the work in question. Progress payments may not be withheld over disputes in workmanship standards.

5. Price & Payment Terms

For the performance of this work the contractor is entitled to the sum quoted in the "Total" line of the "Description" section above. This total is subject to change by approved change orders and selections that are less than or greater than allowance amounts. Payments may be made by Cash, Personal Check, Cashier's Check, ACH, or Wire Transfer. Any fees associated with payment method are the responsibility of the Client to pay and shall not be deducted from the balance owed to Ryals Design Build, LLC. Payment must be made in accordance with the payment schedule except for cases in which it has been agreed upon in writing by all parties to modify the payment schedule. Invoices are to be paid on Net 5 terms unless amended in this contract. Failure by the Client to comply with the payment schedule in any way such as late or incomplete payments, will result in a warning and 5 day grace period to remit full payment for the first offense. If full payment is not made within the grace period or in the case of a second offence, Ryals Design Build, LLC and its subcontractors & suppliers will immediately stop all work on the project and remove all personnel, equipment, tools, materials, and signage from the site and begin the proceedings for filing construction liens against the property in accordance with Oregon law. If the project is re-started after such incident a \$2,000 fee will be assessed to the client to recover the cost of lost time, additional mobilization, and the time-value of money owed.

5a. Allowances

Finish & Fixture Allowances, if used, are dollar values used to approximate the cost of Client selections that have not yet been made. These selections will be billed at direct cost (without markup) and the balance of the allowed cost and actual cost will be applied to the contract price via a change order.

6. Rules of Conduct and Communication

The client shall not communicate directly with any Employees, Subcontractors, or Suppliers of Ryals Design Build, LLC throughout the course of the project except for those Ryals Design Build, LLC employees who have been assigned for that role such as the Superintendent or Project Manager.

6a. Threats, Harassment, & Abuse

Ryals Design Build, LLC has a zero-tolerance policy for fighting, threats, harassment, verbal or physical abuse of any kind. If any employee or agent of Ryals Design Build, LLC or its subcontractors or suppliers exhibits any such behavior, that individual may be issued a verbal warning or immediately removed from the project, depending on severity of incident. If Client exhibits any such behavior, they may be issued a verbal warning or, depending on severity of incident, work may immediately cease and all Ryals Design Build, LLC personnel and subcontractors will leave the site until the issue can be resolved. If mediation is necessary in this scenario, it will be the responsibility of the Client to pay for the cost of mediation and lost time on part of Ryals Design Build, LLC, its employees, and subcontractors.

7. Compliance with Laws, Regulations, & Rules

Ryals Design Build, LLC shall ensure that all work complies with local laws and building codes and obtain all necessary permits and inspections in a timely manner. It is the sole responsibility of the Client to ensure compliance with all HOA requirements, CC&R's, or other private agreements with third parties.

8. Independent Contractor Status

Ryals Design Build, LLC and its subcontractors shall at all times remain independent contractors and it is the sole right of the same to determine the means and methods of completing the contracted work. The employees of Ryals design Build, LLC are solely under its supervision and direction and shall not be directed by the Client or any agent thereof. The subcontractors of Ryals Design Build, LLC, while independent contractors having full authority over their means and methods, have been hired by Ryals Design Build, LLC to complete a specific scope of work and are not under the direction of the Client or any agent thereof.

8a. Subcontractors and other contractors

Ryals Design Build, LLC retains the sole right to subcontract any portion or scope of the work to other companies of their choosing. All subcontractors will be licensed by the State of Oregon and carry liability insurance and worker's comp insurance. Client waives any right to select or hire other contractors to perform any aspects of the work covered by this contract. If client hires any other contractors for unrelated work on-site during the course of the project, he assumes Full Responsibility for any damages or delays that said other contractor may cause to Ryals Design Build, LLC or its subcontractors & suppliers. If the Client wishes to hire any of the Ryals Design

Build, LLC's subcontractors or other contractors not party to this agreement to complete unrelated work on the subject premises, that is their right, however Client assumes full responsibility for any damages or delays that said other contractor may cause to Ryals Design Build, LLC, its subcontractors, and suppliers and their supplies and completed work.

9. Insurance of Structure

Materials incorporated into the structure being worked-on immediately become property of the Client. Throughout the entire project the client shall maintain fire insurance on the structure with extended coverage upon the entire structure on which the work is to be done.

10. Disputes

In the event of a dispute or complaint by the Client against Ryals Design Build, LLC, the Client shall deliver formal notice of deficiency listing all issues with the work or materials. Ryals Design Build, LLC will be given the opportunity to address the problem and make a reasonable offer for its resolution. If an agreement cannot be reached, then parties will go to binding arbitration provided by Arbitration Service of Portland, Inc.

11. Warranty

Ryals Design Build, LLC offers a 1 year workmanship and materials warranty on all projects. Any item, finish, or assembly which does not meet code at the time of construction or does not meet the standard of work common to the local area will be rectified if it is brought to the attention of Ryals Design Build, LLC within 1 calendar year of the date of substantial completion. The Warranty does not cover damage caused by client, client's family or guests, burglary, vandalism, terrorism, or severe weather incidents.

12. Acceptance & Authority

This Contract is hereby agreed upon without reservation or amendment unless explicitly included. By signing, Client acknowledges they are of sound mind & judgement and not under duress of any kind and have received & read all State-required notices from Ryals Design Build, LLC. Client affirms that they have the authority to enter into this contract without reservation or approval from additional parties and that they have notified all other interested parties or additional property owners of the signing of this contract and will deliver to said parties copies of the contract and all other documentation and notices in a timely manner. This contract shall be deemed withdrawn by Ryals Design Build, LLC if a signed copy is not received within 15 calendar days of its presentation to Client. Ryals Design Build, LLC is also entitled to withdraw this contract at any time for any reason prior to its written acceptance by Client.

The above specifications, costs, and terms are hereby accepted.

MICHELLE MADDUX-ROBINSON

DATE

Proposal

975 Ellsworth

DAY HEATING CO.

225 Division St. NE
SALEM, OREGON 97301

787 NE Circle Blvd
CORVALLIS, OREGON 97330

CCB #1090

PROPOSAL SUBMITTED TO Furniture Share		PHONE [REDACTED]	DATE August 6, 2025
STREET PO Box 2224		JOB NAME	
CITY, STATE and ZIP CODE Corvallis, Or 97339		JOB LOCATION 975 Ellsworth St SW Albany, Or 97321	
ARCHITECT	DATE OF PLANS Rev.	Page 1 of 4	JOB PHONE

Bryant Proposal 1: (West Bay)

Perform the following:

- Provide and install a Bryant Ductless Heat Pump, Model 37MHRAQ30 with matching indoor head.
- Includes lift, and permit for the ductless equipment.
- Excludes engineering and high voltage electrical.

Warranty Information

- ✚ One (1) year warranty on parts and labor for all newly installed equipment.
- ✚ Other warranties as provided by the manufacturer.

Installed Price Total: \$10,058.00

Bryant Proposal 2: (East Bay)

Perform the following:

- Provide and install a Bryant Ductless Heat Pump, Model 37MHRAQ30 with matching indoor head.
- Includes lift, and permit for the ductless equipment.
- Excludes engineering and high voltage electrical.

Warranty Information

- ✚ One (1) year warranty on parts and labor for all newly installed equipment.
- ✚ Other warranties as provided by the manufacturer.

Installed Price Total: \$10,058.00

- Outdoor units will sit on the roof for both bays.

We Propose hereby to furnish material and labor – complete in accordance with above specifications, for the sum of:
Cost based on options picked above _____ dollars (\$ _____).

Payment to be made as follows:

Net cash or check, monthly progressive billing. Note: The above prices reflect a 3% discount for payment via cash or check. If another

form of payment is used, the discount will not apply, and the 3% will be added back to arrive at full price.

All material is guaranteed to be as specified. All work to be completed in a workmanlike manner according to standard practices. Any alteration or deviation from above specifications involving extra costs will be executed only upon written orders, and will become an extra charge over and above the estimate. All agreements contingent upon strikes, accidents or delays beyond our control. Owner to carry fire, tornado and other necessary insurance. Our workers are fully covered by Workman's Compensation Insurance.

Authorized
Signature _____

Note: This proposal may be withdrawn by us if not accepted within **30** days.

Acceptance of Proposal The above prices, specifications and conditions are satisfactory and are hereby accepted. You are authorized to do the work as specified. Payment will be made as outlined above. If collection action must be taken against this account, I agree to pay Day Heating's reasonable collection costs and attorney fees. Day Heatings account terms apply.

Signature: _____

Date of Acceptance: _____

Proposal

975 Ellsworth

DAY HEATING CO.

225 Division St. NE
SALEM, OREGON 97301

787 NE Circle Blvd
CORVALLIS, OREGON 97330

FAX (503) 363-3682

CCB #1090

PROPOSAL SUBMITTED TO Furniture Share		PHONE (541)754-9511	DATE August 6, 2025
STREET PO Box 2224		JOB NAME	
CITY, STATE and ZIP CODE Corvallis, Or 97339		JOB LOCATION 975 Ellsworth St SW Albany, Or 97321	
ARCHITECT	DATE OF PLANS Rev.	Page 2 of 4	JOB PHONE

Option: (East Bay unit heater only)

Perform the following:

- Provide and install a Reznor unit heater Model UDXC75 in place of the existing unit.
- Includes reconnection to the existing flue, gas line, and electrical.
- Provide and install a new Honeywell thermostat T4.

Warranty Information

- ✚ One (1) year warranty on parts and labor for all newly installed equipment.
- ✚ Other warranties as provided by the manufacturer.

✚ **Installed Price Total:** \$4,211.00

We Propose hereby to furnish material and labor – complete in accordance with above specifications, for the sum of:
Cost based on options picked above _____ dollars (\$ _____).

Payment to be made as follows:

Net cash or check, monthly progressive billing. Note: The above prices reflect a 3% discount for payment via cash or check. If another

form of payment is used, the discount will not apply, and the 3% will be added back to arrive at full price.

All material is guaranteed to be as specified. All work to be completed in a workmanlike manner according to standard practices. Any alteration or deviation from above specifications involving extra costs will be executed only upon written orders, and will become an extra charge over and above the estimate. All agreements contingent upon strikes, accidents or delays beyond our control. Owner to carry fire, tornado and other necessary insurance. Our workers are fully covered by Workman's Compensation Insurance.

Authorized
Signature _____

Note: This proposal may be withdrawn by us if not accepted within **30** days.

Acceptance of Proposal The above prices, specifications and conditions are satisfactory and are hereby accepted. You are authorized to do the work as specified. Payment will be made as outlined above. If collection action must be taken against this account, I agree to pay Day Heating's reasonable collection costs and attorney fees. Day Heatings account terms apply.

Signature: _____

Date of Acceptance: _____

Proposal

975 Ellsworth

DAY HEATING CO.

225 Division St. NE
SALEM, OREGON 97301

787 NE Circle Blvd
CORVALLIS, OREGON 97330

CCB #1090

PROPOSAL SUBMITTED TO Furniture Share		PHONE [REDACTED]	DATE August 6, 2025
STREET PO Box 2224		JOB NAME	
CITY, STATE and ZIP CODE Corvallis, Or 97339		JOB LOCATION 975 Ellsworth St SW Albany, Or 97321	
ARCHITECT	DATE OF PLANS Rev.	Page 3 of 4	JOB PHONE

Daikin Proposal 1: (West Bay)

Perform the following:

- Provide and install a Daikin Ductless Heat Pump, Model RX30WMVJU9 with matching indoor head.
- Includes lift, and permit for the ductless equipment.
- Excludes engineering and high voltage electrical.

Warranty Information

- ✚ One (1) year warranty on parts and labor for all newly installed equipment.
- ✚ Other warranties as provided by the manufacturer.

Installed Price Total: \$9,131.00

Daikin Proposal 2: (East Bay)

Perform the following:

- Provide and install a Daikin Ductless Heat Pump, Model RX30WMVJU9 with matching indoor head.
- Includes lift, and permit for the ductless equipment.
- Excludes engineering and high voltage electrical.
-

Warranty Information

- ✚ One (1) year warranty on parts and labor for all newly installed equipment.
- ✚ Other warranties as provided by the manufacturer.

✚ **Installed Price Total:** \$9,131.00

- Outdoor units will sit on the roof for both bays.

We Propose hereby to furnish material and labor – complete in accordance with above specifications, for the sum of:
Cost based on options picked above _____ dollars (\$ _____).

Payment to be made as follows:

Net cash or check, monthly progressive billing. Note: The above prices reflect a 3% discount for payment via cash or check. If another

form of payment is used, the discount will not apply, and the 3% will be added back to arrive at full price.

All material is guaranteed to be as specified. All work to be completed in a workmanlike manner according to standard practices. Any alteration or deviation from above specifications involving extra costs will be executed only upon written orders, and will become an extra charge over and above the estimate. All agreements contingent upon strikes, accidents or delays beyond our control. Owner to carry fire, tornado and other necessary insurance. Our workers are fully covered by Workman's Compensation Insurance.

Authorized
Signature _____

Note: This proposal may be withdrawn by us if not accepted within 30 days.

Acceptance of Proposal The above prices, specifications and conditions are satisfactory and are hereby accepted. You are authorized to do the work as specified. Payment will be made as outlined above. If collection action must be taken against this account, I agree to pay Day Heating's reasonable collection costs and attorney fees. Day Heatings account terms apply.

Signature: _____

Date of Acceptance: _____

Proposal

975 Ellsworth

DAY HEATING CO.

225 Division St. NE
SALEM, OREGON 97301

787 NE Circle Blvd
CORVALLIS, OREGON 97330

CCB #1090

PROPOSAL SUBMITTED TO Furniture Share		PI [REDACTED]	DATE August 6, 2025
STREET PO Box 2224		JOB NAME	
CITY, STATE and ZIP CODE Corvallis, Or 97339		JOB LOCATION 975 Ellsworth St SW Albany, Or 97321	
ARCHITECT	DATE OF PLANS Rev.	Page 4 of 4	JOB PHONE

Option: (East Bay)

Perform the following: **This unit was previously installed.**

- Provide and install a Daikin Ductless Heat Pump, Model RX24k with matching indoor head.
- Includes lift, and permit for the ductless equipment.
- Excludes engineering and high voltage electrical.
-

Warranty Information

- ✚ One (1) year warranty on parts and labor for all newly installed equipment.
- ✚ Other warranties as provided by the manufacturer.

✚ **Installed Price Total:** \$5,689.00

➤

We Propose hereby to furnish material and labor – complete in accordance with above specifications, for the sum of:
Cost based on options picked above _____ dollars (\$ _____).

Payment to be made as follows:

Net cash or check, monthly progressive billing. Note: The above prices reflect a 3% discount for payment via cash or check. If another

form of payment is used, the discount will not apply, and the 3% will be added back to arrive at full price.

All material is guaranteed to be as specified. All work to be completed in a workmanlike manner according to standard practices. Any alteration or deviation from above specifications involving extra costs will be executed only upon written orders, and will become an extra charge over and above the estimate. All agreements contingent upon strikes, accidents or delays beyond our control. Owner to carry fire, tornado and other necessary insurance. Our workers are fully covered by Workman's Compensation Insurance.

Authorized
Signature _____

Note: This proposal may be withdrawn by us if not accepted within **30** days.

Acceptance of Proposal The above prices, specifications and conditions are satisfactory and are hereby accepted. You are authorized to do the work as specified. Payment will be made as outlined above. If collection action must be taken against this account, I agree to pay Day Heating's reasonable collection costs and attorney fees. Day Heatings account terms apply.

Signature: _____

Date of Acceptance: _____



QUOTE NO.	9131	ISSUE DATE	3/25/2026	VALID UNTIL	3/25/2026
------------------	------	-------------------	-----------	--------------------	-----------

FROM Bravery Group Inc. CCB 256502. 2397 Northwest Kings Blvd, 315 Corvallis OR 97330 United States	FOR Furniture Share
--	-------------------------------

DESCRIPTION	QUANTITY	UNIT PRICE (\$)	DISCOUNT %	AMOUNT (\$)
-------------	----------	-----------------	------------	-------------

<p>Showroom & ADA Bathroom Renovation *</p> <p>Scope of Work Permits Contractor to pull all required permits. Plans are excluded and to be provided by the owner.</p> <p>Demolition Remove existing drywall from ceiling. Remove existing insulation.</p> <p>Framing Construct new framing within concrete walls on three (3) sides.</p> <p>Electrical & Lighting Includes labor and materials for the following: Install up to ten (10) 120V outlets throughout showroom.</p> <p>Provide and install up to twenty-four (24) LED light fixtures for general lighting. Provide and install bathroom lighting controlled by switch. Provide and install bathroom exhaust fan. Provide power and connect water heater.</p> <p>Insulation Install R-15 insulation in walls. Install R-30 insulation in ceiling. Install R-8 insulation for garage doors.</p> <p>Drywall Install 5/8" drywall on walls and ceilings. Tape, mud, and apply orange peel texture finish.</p> <p>Prime & Paint</p>	1	81,698.58	0.00	81,698.58
--	---	-----------	------	-----------

Prime and paint all walls and ceilings.
DESCRIPTION Renovation (ADA Compliant)

QUANTITY **UNIT PRICE (\$)** **DISCOUNT %** **AMOUNT (\$)**
975 Ellsworth

Demolition:
Demolish existing bathroom including framing, drywall, toilet, and vanity.

Construction:
Build new 7.5' x 6.5' bathroom framing to meet ADA compliance requirements.
Relocate water heater.
Relocate 1-1/2" sewer line and water supply lines.

Fixtures & Finishes:
Install new toilet and sink with faucet.
Install LVP flooring and cove base.
Install FRP panels up to 48" height on bathroom walls.
Install drywall on walls and ceiling; tape, mud, and texture.
Prime and paint.

Accessories:
Install ADA grab bars.
Install toilet paper holder, paper towel dispenser, and soap dispenser.
Install mirror.

Electrical:
Install new exhaust fan.
Install electrical outlet.
Install ceiling light fixture.

Exclusions
Architectural and engineering plans (by owner).
Any unforeseen conditions or code-required upgrades not listed above.

Notes
All work will be performed in accordance with local building codes.
Final pricing subject to site inspection and material selections.

Total (USD): **\$81,698.58**

THANK YOU FOR TRUSTING US TO HELP YOU WITH YOUR GOALS

Issued by, signature:





Supreme Projects

3735 Amber Street Northeast | Salem, Oregon 97301

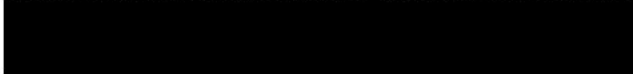

RECIPIENT:

Diana Debray
975 Ellsworth St. SW
Albany, OR 97321
Phone:

Quote #677	
Sent on	Feb 09, 2026
CCB	233799
Terms & Agreement	By approving this quote, you agree to the attached terms.
Total	\$88,300.00

Product/Service	Description	Total
Permits	- Pull permits (city fees included) - Plans is not included. (provided by customer)	\$4,500.00
Demolition	- Remove the existing drywall from the ceiling and insulation.	\$1,850.00
Framing	Construct a new frame within the concrete wall at three walls.	\$8,500.00
Electrical	Electrical & Lighting upgrades for show room Includes labor and material for the following: Instal up to 10 120v outlets around the show room. Provide and install up to 24 LED light fixtures for general lighting. Provide and install light for bathroom controlled by switch. Provide and install bathroom fan . provide power and connect water heater.	\$9,250.00
Insulation	- Install R-15 insulation in walls and R-30 in ceiling. - Install R-8 for garage doors.	\$14,350.00
Drywall	Install 5/8" drywall at ceiling and walls, mud it, and orange pill texture it.	\$23,700.00
Prime and Paint	Prime and paint walls and ceiling.	\$8,750.00
Bathroom	- Demolish existing bathroom, with frame, drywall, toilet, and vanity. - Build new 7.5x6.5 frame for ADA compliance bathroom. - Relocate water heater, 1 1/2 sewer pipe and water pipes. - Install new toilet, and sink with faucet. - Install new LVP floors in the bathroom and install covebase. - Install FRP panel 48 inches high on interior of the bathroom. - Install drywall on both sides of the bathroom and ceiling, mud, and texture. - Prime and paint. - Instal grab bars. - Install new toilet paper holder, paper towel holder, and soap dispancer. - Install new mirror. - Install new exhaust fan, electrical outlet, and ceiling light.	\$16,500.00



Supreme Projects

3735 Amber Street Northeast | Salem, Oregon 97301



Product/Service	Description	Total
Garbage	Haul away all construction debris.	\$900.00
		Total
		\$88,300.00

Extra charge if additional work will be required
A deposit of 50% will be required to begin.

By approving this quote, you agree to the attached terms and agreement.

Signature: _____ Date: _____



Project Evaluation Grid: 975 Ellsworth Street SW

Request: \$75,000

	Item	Description	Staff Analysis/Comments
<i>Overall Goals</i>			
A)	<p>CARA Goal & Objectives: The purpose of this CARA Plan is to eliminate blighting influences found in the CARA, to implement goals and objectives of the City of Albany Comprehensive Plan, and to implement development strategies and objectives for the CARA. The goal and objectives for the CARA have been defined as follows:</p> <p>CARA Goal: To revitalize the Central Albany Revitalization Area by implementing the Town Center Plan developed through the Central Albany Land Use & Transportation Study (CALUTS) using a citizen-driven process.</p>	<p>Does the project further the Town Center Plan?</p> <p>Which of CARA's objectives does the project meet?</p> <p>CARA Key Objectives:</p> <ul style="list-style-type: none"> ◆ Attract new private investment to the area. ◆ Retain and enhance the value of existing private investment and public investment in the area. <p>CARA Additional Objectives:</p> <ul style="list-style-type: none"> ◆ Provide a safe and convenient transportation network that encourages pedestrian & bicycle access to and within the town center. ◆ Preserve the Historic Districts, historic resources and existing housing in the area. ◆ Create a readily identifiable core that is unique and vibrant with a mixture of entertainment, housing, specialty shops, offices, and other commercial uses. ◆ Increase residential density in the area. ◆ Encourage the development of new forms of housing and home ownership. ◆ Enhance and protect the community and environmental values of waterway corridors in the area. ◆ Provide an enriching environment and livable neighborhoods. 	<p>Yes.</p> <p>This project meets CARA's two key objectives as listed.</p> <p>Additional objectives met:</p> <p>Readily identifiable core Enriching environment</p>
B)	CARA Planned Projects	Which project category and activity in the UR Plan does this project fulfill? (See CARA Project Activities document, or Table 2 of the UR Plan and Report.)	Commercial Building Rehabilitation, Transition Areas Redevelopment
C)	Development Pattern (Highest and Best Use)	Does it achieve desired land use (e.g., mixed-use, higher density) and/or transportation objectives (e.g., Esplanade, pedestrian-friendly areas)? Is the proposed project desired in this location and the highest and best use of the property?	Zone: Lyon-Ellsworth Yes, the proposed project falls within the options for highest and best use of the property.
D)	Blight	Would it remedy a severely blighted building? How? Does the project utilize a vacant space?	No.

E)	Preservation	Would it rehabilitate or sensitively redevelop a historic property?	No.
F)	Vitality/People Attractor	Does the general public benefit (i.e. restaurant, carousel, something they can go to; does the project enhance the public's experience of the space; is it a business we are seeking)?	Supports existing use by a non-profit organization.
G)	Retail Hotspot (First Avenue between Lyon and Calapooia)	Is the project located in the Retail Hotspot? If so, will the first floor use be active retail, as recommended in the Retail Refinement Plan?	No.
H)	Sustainable Building	Will the building be built using sustainable practices including LEED or others?	Not addressed in application.
I)	Residential	Is there a residential component? How many units?	No.
<i>Economic Development</i>			
J)	Bring new business to Albany	Will a new business open or come to Albany as a part of this project?	No.
K)	Job Creation	Will the project create additional jobs? How many, what types and what salary level?	1 full time and 2 part time positions. Salary levels not identified.
L)	Local Labor and Materials	Has applicant specifically called out a commitment to use a certain percent or amount of local labor and/or materials?	Not specifically called out in application.
<i>Financial</i>			
M)	Ratio	Proposed public funds Private funds % of CARA Investment	Applicant requesting 75% of total project costs.
N)	Financial Impacts	What are the financial risks and/or financial benefits to CARA?	Reimbursement based-grant; low financial risk. Benefits through increased value.
O)	Gap	What is the "Gap" or need of the developer?	\$75,000
P)	Private Risk	What is the risk for the developer? What is their skin in the game?	\$25,000 for this phase of the project.
Q)	CARA/City funds	Has the project received other CARA/City funding in the past?	No.
R)	Tax Increment ROI	Is the ROI on this project less than 5 years, less than 7 years?	ROI will be achieved through increased property value.



CARA GRANT APPLICATION

1. APPLICANT

Name: Alex Rice

Mailing Address: [REDACTED]

[REDACTED] Zip Code: [REDACTED]

Title: Member, Board of Directors Phone Number: [REDACTED]

E-mail Address: [REDACTED]

2. BUSINESS/BUILDING INFORMATION

Legal Business Name: Cumberland Community Events Center

Number of Years in Operation: 7

Legal Form: Sole Proprietorship Partnership Corporation S-Corp LLC
 Profit Nonprofit

EIN: [REDACTED]

In which state are the incorporation and/or organization documents filed? Oregon

Have you ever filed for bankruptcy? Yes No

Project Address (if different than mailing address): 1400 Santiam RD SE, Albany, OR 97321

Property Tax Account Number: 844221

Is the building a historic contributing resource? Yes No

If so, is it on the historic property-tax freeze? Yes No

3. OWNER OF PROPERTY (if not applicant)

Name in which title is held: _____

Contact Name: _____

Mailing Address: _____

_____ Zip Code: _____

Phone Number: _____

4. AUTHORIZATION TO UNDERTAKE WORK:

If the applicant is not the owner of the property, provide written evidence that the owner authorizes this work to be undertaken. (Typically this is in the form of a lease or other written permission.)

5. DESCRIPTION OF PROJECT *Please give a comprehensive description of project.*

The Cumberland Community Events Center (CCEC) is a 501(c)(3) nonprofit organization that formed in 2019 for the purpose of saving the historic Cumberland Presbyterian Church building and restoring it into an asset of the community. Currently we are entirely focused on rehabilitating the historic structure and upgrading it so that it can be used for community events and community services.

Once complete, the Cumberland Events Center will offer educational and enrichment programs for children and families to promote the social well-being of the community, provide a facility for the arts, education, recreation, coordinate and host programs that engage youth before and/or after school, celebrate locally-based activities in order to increase the opportunity for personal and collective growth in our community, and work closely with other community based organizations to host events designed to uplift and empower youth from low-to moderate income households.

In 2019, the CCEC formed for the purpose of raising the funds to move the building to its current location at the corner of Santiam and Pine in order to save it from demolition. Since then work has been focused on restoring the formerly derelict building. Since relocation, the exterior of the building including the roof, siding, doors, and windows have been completely restored. Work is ongoing on the interior of the structure to restore the meeting space, which had been heavily modified to support different uses over the years, and achieve certificate of occupancy. A small extension is planned to support storage space, restrooms, and kitchen prep space. Additionally, egress is still needed with access designed for people with disabilities.

CARA Funds will be used to cover system development charges and the cost of utility connections. This will allow us to overcome a major obstacle towards the goal of achieving certificate of occupancy in early 2027.

6. TIMELINE FOR COMPLETION OF PROJECT: June 2026 - February 2027 (CARA Portion June-Sept. 2026)

7. PROJECT COSTS

ESTIMATED COST OF PROJECT: \$ 877,300.00

ESTIMATED VALUE OF PROJECT UPON COMPLETION: \$ 1,314,110.00

Basis for valuation and value upon completion: Project costs plus capital investments to date (Including land value)

SOURCES FOR PROJECT:

Owner/Company Contribution	\$ <u>441,160.00</u>
Bank (estimated)	\$ <u>0.00</u>
Other private funds (please specify)	\$ <u>261,760.00</u>
Other governmental (please specify)	\$ <u>65,280.00</u>
CARA (proposed)	\$ <u>109,100.00</u>
TOTAL SOURCES	\$ <u>877,300.00</u>

Is your funding for these: available today applied for unknown at this time

USES FOR PROJECT:

Land and/or Building Acquisition	\$ _____
Soft Costs (architectural, engineering, financing, and legal fees, and other pre- and post-construction expenses.) *	\$ <u>60,000.00</u>
Construction Costs *	\$ <u>817,300.00</u>
Tenant Improvements	\$ _____
Machinery/Equipment/Installation Costs	\$ _____
Working Capital	\$ _____
Other (please specify)	\$ _____
TOTAL USES	\$ <u>877,300.00</u>

*Please provide a detail of Soft Costs and of Construction Costs (Please attach).

8. PREPARATION OF COST ESTIMATES

Who prepared your cost estimates? Varitone Architecture (Soft Costs), Pyburn and Sons Building and Remodeling (Construction costs)

(If applicant prepared their own estimate, verification may be required. **Please attach minimum of two bids, preferably three.**)

Mailing Address: [REDACTED]

Phone Number [REDACTED]

9A. EXPLAIN WHY CARA FUNDING IS NECESSARY TO INSURE PROJECT COMPLETION.

(Please provide a description of the financial gap requiring CARA assistance.)

CARA funding would allow us to cover our System Development Charges and the cost of connecting utilities. These are major benchmarks on the path to achieving certificate of occupancy which will allow us to start hosting events and providing a space for needed community services. These two items constitute gaps in necessary funding for which Grant assistance is often less forthcoming. Although completely necessary to our mission and the completion of our project they are a less tangible budget item that is often less appealing to philanthropic funders. CARA funding would allow us to overcome this obstacle and focus other fundraising efforts on the rehabilitation of the building itself.

9B. IF YOU DON'T RECEIVE THE FUNDS, WHAT COMPONENTS WILL BE DROPPED? WOULD THE PROJECT GET DONE WITHOUT CARA FUNDS? (Please provide a detailed explanation.)

Without CARA funding the project timeline would likely be longer as we would need to find other ways to secure necessary funding. This would lead to a delay in the delivery of services, and likely in an increase in cost of the overall project. It would also elongate the period of time in which the building sits idle, doing much less for the neighborhood. With the award of CARA funding we would be on track to open our doors sometime in early 2027.

10. WHERE ELSE HAVE YOU LOOKED FOR FUNDING?

We have \$370,350 of secured funding currently and another \$184,500 in pending and potential grants from the Johanna Favrot Fund, the Kinsman Foundation, and the MJ Murdock Charitable Trust. We also forecast and additional approximately \$125,350 in donations. A very large portion of our current funding has come from private donations. Other past foundation funders include the Kinsman Foundation, the Marie Lamfrom Charitable Foundation, and CAF America. Additionally, state funding has helped the project from The Oregon Cultural Trust and Oregon SHPO. In general, our funding sources are diverse and we continue to seek grant funding on an ongoing basis.

11. CONSIDERING THE PROJECT GOALS OUTLINED IN THIS APPLICATION, PLEASE IDENTIFY THE VALUE YOUR PROJECT BRINGS TO CARA.

In line with the stated objectives of CARA, this project would serve to preserve historic resources in the area. The Cumberland Presbyterian Church building, now the Cumberland Community Events Center is on the National Register of Historic Places. We have already partially met the objective by saving the building from demolition when we moved it in 2021. Now we are working to preserve the building in perpetuity by transforming what had been a derelict historic structure into an asset of the community which will serve the needs of a changing yet historically underrepresented neighborhood.

Given that one of the aims of this project is to acquire adjacent, city owned lots for further use in our mission, this project will serve to convert empty, surplus property into productive space, generating ample value for the city. Additionally, this project will serve to meet CARA's stated objective of providing an enriching environment and livable neighborhoods. CCEC will provide a community gathering space in a neighborhood where gathering spaces are limited to bars and churches. CCEC will create a third space for the community as well as a space for community focused organizations to deliver much needed programs with a special emphasis on youth programs.

This project achieves activities outlined in the Urban Redevelopment Plan. Specifically, this project would create gateway amenities in the Gateway to Central Albany by enhancing amenities near Pacific and Santiam. This project also improves mixed use value by creating a flexible gathering space in a residential area. Additionally this project will rehabilitate a severely blighted building by transforming a structure that was slated for destruction into usable space while also achieving the goal of historic preservation. Finally, the project will also create an attractive site for visitors by providing a nucleus for local history as well as being one of the only examples of a Queen Anne style Church in the Willamette Valley.

12. PLEASE OUTLINE ANY OTHER BENEFITS YOUR PROJECT PROVIDES.

(To Albany, and the area/neighborhood)

This project will breathe new life into the historic Cumberland Presbyterian Church building, transforming it from a derelict former house of worship into an asset for the community capable of uplifting historically under-served populations. Rental fees for parties, weddings, and similar events will provide for the solvency of the organization so that we can keep the doors open and provide space for community focused organizations at little or no cost. In this way, we will provide for the longevity of programming that will continue to benefit the community into the future.

In 2019, the historic Cumberland building was under threat of demolition until the CCEC was formed and raised funds to move the building to its current location. Where it now sits at the corner of Santiam Hwy and Pine St. was an empty lot and former mill pond. This project has already served to eliminate liminal space that constituted an attractive nuisance in a neighborhood that has seen a fair amount of crime and undesirable traffic in the past. The presence of the Cumberland Community Events Center will serve to increase positive traffic in the area and encourage pro-social activities, improving the condition of the neighborhood and reducing the potential for criminal and nuisance activity. Additionally, the presence of the fully restored historic structure will serve to raise surrounding property values generating wealth in an economically disadvantaged area. Finally, the neighborhood in which the Cumberland sits is quite dark at night, the Cumberland will be well lit at night making the area safer for community members which will have a particular benefit for shift workers and others who work outside traditional hours.

13. HAVE YOU OR THIS PROPERTY RECEIVED CARA FUNDING AT ANY POINT IN THE PAST?

No Yes If so, amount \$ _____

FOR WHAT PROJECT(S): _____

WHEN? _____

14. ASSISTANCE REQUESTED

Total Estimated Project Costs:	\$ <u>877,300.00</u>
Your Total Contribution	\$ <u>768,200.00</u>
Total Amount Requested from CARA:	\$ <u>109,100.00</u>

Final payment will be based on actual costs not estimates. **Ten percent of CARA funds will be held back for final payment.**

15. BREAKDOWN OF USE OF CARA FUNDS

***CARA funds can only be used for permanent improvements to the building.** Please provide a breakout with specific details of how the CARA funds will be used in the project. If more space is needed, please attach a separate page.*

Item	Amount	Notes
System Dev. Charges (SDCs)	\$40,600.00	
Public Utility Connection Charges	\$60,200.00	
Public Works fee	\$3,300.00	
Administration (acctg, compliance, reporting)	\$5,000.00	
TOTAL	\$109,100.00	Total should match total amount requested from CARA from line 14.

Metrics and Other Benefits

If you receive funding, you will be asked to tally the final figures on the project and certify their accuracy. Please use this space to estimate the impact of your project:

Number of Jobs Created: _____ Full-time 1 Part-Time

Certification

The Applicant understands and agrees to the following conditions:

1. Any physical improvements proposed must be approved by the Albany Revitalization Area Agency (ARA) and may require approval by the City of Albany Landmarks Advisory Commission or other entities. These entities may require certain changes or modifications before final approval and Commitment of Funds.
2. Any work begun before receipt of a Contract notice is ineligible for reimbursement.
3. Any work deviating from that detailed in the Contract must be preapproved in writing to be eligible for reimbursement.
4. While only proprietary information may be held in confidence outside of the public record, ARA will attempt to maintain all information provided in a confidential manner.
5. Originals of all materials prepared with ARA assistance belong to ARA and will be maintained in the public record.
6. Application must be completed in its entirety before being considered; if not, it will be returned for completion.
7. Staff is authorized to independently verify any and all information contained in this application.
8. ARA may withhold approval of this application until information satisfactory to ARA is provided.

The Applicant certifies that all information in this application and all information furnished in support of this application is given for the purpose of obtaining ARA assistance and is true and complete to the best of the Applicant's knowledge. Applicant further acknowledges the undersigned applicant(s) have read and understand CARA's privacy policy and have completed this form with accurate information.

Alexander Rice

Applicant's Printed Name	Applicant's Printed Name
	Date <u>3/25/2026</u>
Applicant's Signature	Date

Return application/attachments to: City of Albany c/o Sophie Adams, Economic Development Manager: sophie.adams@albanyoregon.gov

**Construction Cost Estimate
Cumberland Community Events Center**

Element	Cost
System Dev. Charges (SDCs)	\$40,600
Public Utility Connection Charges	\$60,200
Public Works Fee	\$3,300
Permits	\$7,600
General Conditions	\$70,200
Special Inspections	\$2,500
Site Work (excl. fire sprinkler)	\$147,000
Mechanical	\$56,000
Plumbing	\$16,700
Fire Sprinkler System	\$81,800
Electrical	\$81,900
Framing & Structural	\$53,500
Walls & Ceilings	\$73,800
Floor Covering	\$17,400
Doors & Glazing	\$17,100
Moulding & Millwork	\$83,300
Casework & Countertops	\$2,000
Appliances & Accessories	\$2,400
Total	\$817,300

**Estimate of Soft Costs
Cumberland Community Events Center**

Element	Cost
Architectural Design Services	
Design development	\$25,000
Construction documents	\$15,000
Construction administration	\$5,000
Engineering Design Services	
Structural engineering	\$3,000
Civil engineering	\$7,000
Administration (acctg, reporting)	\$5,000
Total	\$60,000

Project Funding Plan Cumberland Building Renovation

Funding Sources	Contributed	Potential
Individuals ⁽¹⁾	\$262,370	\$90,000
Volunteer labor ⁽²⁾	\$16,808	\$10,350
Foundations ⁽³⁾	\$21,500	\$184,500
Corporations	\$17,760	\$38,000
Government ⁽⁴⁾	\$15,281	\$159,100
Fundraising events	\$36,632	\$25,000
Total	\$370,350	\$506,950
Funding Totals		
Total Project Cost	\$877,300	
Total Given/Pledged	\$370,350	
Total to Be Secured	\$506,950	

NOTES

- (1) Average 75 individual donors annually.
- (2) Reflects 271 volunteer hours in 2024 & 184 volunteer hours in 2025.
- (3) Secured: Kinsman Fdn-\$15,000, Marie Lamfrom Charitable Fdn-\$4,000, CAF America-\$2,500
Potential: MJ Murdock Fdn-\$69,500, Kinsman Fdn-\$100,000, Favrot Fund-\$15,000
- (4) Secured: Oregon Cultural Trust-\$13,634, Oregon SHPO-\$1,647
Potential: CARA-\$109,100, Oregon Cultural Trust-\$5,000, National Trust-\$25,000, National Park Svc-\$20,000

AGREEMENT TO PROVIDE ARCHITECTURAL SERVICES: COMMERCIAL PROJECT

DATE: September 17, 2024

PARTIES:

VARITONE ARCHITECTURE, LLC..... (hereinafter "Architect")
PO BOX 3420
231 SW 2nd Ave.
ALBANY, OREGON 97321

Cumberland Community Events Center..... (hereinafter "Owner")
ATTN: Joel Orton
P.O. Box 2495
Albany, OR 97321

AGREEMENT:

This Agreement shall constitute the terms and conditions under which Architect shall provide schematic architectural services for a historic renovation by Owner at 1400 Santiam Road, City of Albany, County of Linn, State of Oregon.

SECTION ONE
COMPENSATION

A. Owner agrees to pay Architect an hourly not-to exceed fee for services on attached exhibits A and B, which totals twenty-three thousand, five-hundred and sixty dollars (\$23,560.00). These services are for Schematic Design and Design Development identified below without renegotiation, unless there is a change to the scope of services. Owner agrees to pay Architect for services below:

1. Architectural	\$23,560.00
2. Structural Engineering.....	\$N/A
3. Civil Engineering	\$N/A
4. Mechanical & Electrical Engineering	\$N/A
<hr/>	
Total Costs	\$23,560.00

B. Owner agrees to pay for reimbursable expenses listed below at cost plus 3%:

Expense of original plots, reproductions, renderings, mock-ups, models, and the postage and handling of drawings and other documents.

Any payments shall be made by Owner within 15 days of receipt of any billing statement. Client is billed at the end of each month. Interest shall accrue on any unpaid balance after 30 days at a rate of 5% per annum until paid.

C. Work other than that described in attachment B shall be considered additional work, subject to additional fees as approved by written change order or additional proposal(s) and billed at hourly rates shown on attached exhibit A.

D. Personnel fees listed in Exhibit A are valid for two years from the date of signed contract, after which point fees remaining in contract will be automatically adjusted to reflect Architect's most recently published personnel fee schedule. This adjustment will be presented to Owner for their information.

SECTION TWO ARCHITECTURAL SERVICES

Architect agrees to provide the architectural services listed on attached exhibit B.

The Architect may provide Additional Services after execution of this Agreement without invalidating the Agreement. Except for services required due to the fault of the Architect, any Additional Services provided in accordance with this Section shall entitle the Architect to additional compensation per the Architect's fee schedule.

Upon recognizing the need to perform the following Additional Services, the Architect shall notify the Owner with reasonable promptness and explain the facts and circumstances giving rise to the need. The Architect shall not proceed to provide the following Additional Services until the Architect receives the Owner's written authorization.

SECTION THREE ENGINEERING EXPENSES

Architect will subcontract engineering and specialty consultant services to be performed on the project as required. The subcontracted consultants are not included in this contract. These subcontractor fees will be additional services if or when they are required.

SECTION FOUR ARCHITECT'S DUTIES TO ADVISE, SUPERVISE AND INSPECT

A. Architect will advise owner in writing of any omissions, substitutions, defects, and deficiencies noted in the work of contractors, but does not guarantee the performance of their contract.

B. The supervision of Architect is to be distinguished from the continuous personal supervision to be obtained by a resident inspector. Architect shall visit the project at intervals appropriate to the stage of construction or as otherwise agreed by the Owner and Architect to become generally familiar with the progress and quality of the work completed and to determine in general if the work is being performed in a manner indicating that the Work when completed will be in accordance with the Contract Documents.

C. When authorized by Owner, a resident inspector, satisfactory to both Owner and Architect, shall be employed by Architect at a salary satisfactory to Owner, who shall reimburse Architect for such salary, in addition to the Architect's fee previously agreed upon.

SECTION FIVE OWNER'S RESPONSIBILITIES

A. The Owner shall provide complete, accurate and reliable information in a timely manner regarding its requirements for the Project and shall designate a Project Representative authorized to act in its behalf. The Owner's program shall set forth the Owner's objectives, schedules, constraints, and criteria, including space requirements, and relationships, flexibility, expandability, special equipment, systems, and site requirements.

B. The Owner shall bear all Project expenses relating to local authority fees, permits, filings, submittals, and utility connections, expansions, reductions, and relocations.

C. The Owner shall furnish surveys to describe physical characteristics, legal limitations, and utility locations for the site of the Project, and a written legal description of the site. The surveys and legal information shall include, as applicable, grades and lines of streets, alleys, pavements and adjoining property and structures; designated wetlands; adjacent drainage; rights-of-way, restrictions, easements, encroachments, zoning, deed restrictions, boundaries and contours of the site; locations, dimensions, and other necessary data with respect to existing buildings, other improvements and trees; and information concerning available utility services and lines, both public and private, above and below grade, including inverts and depths. All the information on the survey shall be referenced to a Project benchmark.

D. The Owner shall furnish services of geotechnical engineers, which may include test borings, test pits, determinations of soil bearing values, percolation tests, evaluations of hazardous materials, seismic evaluation, ground corrosion tests and resistivity tests, including necessary operations for anticipating subsoil conditions, with written reports and appropriate recommendations.

E. The Owner agrees to engage a General Contractor as licensed and defined in the Project's relevant jurisdictions for construction of Project. The Owner may not act as General Contractor of the Project without written notice to Varitone prior to issuance of Contract Documents for permit purposes. Owner shall indemnify and hold harmless Varitone and its employees, affiliates, agents, and consultants from and against all claims, damages, losses, and expenses, including without limitation attorney's fees, arising out of Owner's actions as General Contractor. Failure to notify and indemnify Varitone will result in Termination of Agreement for reason of noncompliance.

F. The Owner shall include the Architect in all communications with the Contractor that relate to or affect the Architect's services or professional responsibilities. The Owner shall promptly notify the Architect of the substance of any direct communications between the Owner and the Contractor otherwise relating to the Project. Communications by and with the Architect's consultants shall be through the Architect.

SECTION SIX OWNERSHIP OF DRAWINGS; INDEMNIFICATION BY OWNER

A. Any reports, drawings, specifications, work product, and other pertinent data developed for the Project by Varitone (the "Instruments of Service") are the property of Varitone. Varitone and Varitone's consultants shall be deemed the authors and owners of their respective Instruments of Service, and shall retain all common law, statutory and other reserved rights, including copyrights. Submission or distribution of Instruments of Service to meet official regulatory requirements or for similar purposes in connection with the Project is not to be construed as publication in derogation of the reserved rights of Varitone and Varitone's consultants. Upon execution of this Agreement, Varitone grants to the Owner a non-exclusive license to use Varitone's Instruments of Service solely and exclusively for purposes of constructing, using, maintaining, altering, and adding to the Project, provided that the Owner substantially performs its obligations, including prompt payment of all sums when due, under this Agreement. Varitone shall obtain similar nonexclusive licenses for the benefit of the Owner from Varitone's consultants consistent with this Agreement. The license granted under this section permits the Owner to authorize the Contractor, Subcontractors, Sub-subcontractors, and material or equipment suppliers, as well as the Owner's consultants and separate contractors, to reproduce applicable portions of the Instruments of Service solely and exclusively for use in performing services or construction for the Project.

B. If Varitone terminates this Agreement as provided for in this contract, the license granted in this Section shall terminate. Notwithstanding the foregoing: (a) the Instruments of Service shall not be used with respect to any project other than this Project without Varitone's prior written consent, which

may be granted or withheld in Varitone's sole discretion, and Owner releases Varitone from all such claims and damages arising out of such uses, and (b) the Instruments of Service may be used by the Owner for additions to this Project by others or for completion of this Project by others only on the conditions that (i) the Owner assumes all risks and responsibilities associated with such use of the Instruments of Service and releases Varitone from all such claims and damages arising out of such uses, and (ii) the Owner shall defend, indemnify and hold harmless Varitone and its officers, directors, employees, affiliates, and agents from and against all claims, damages, losses and expenses, including without limitation attorneys' fees, arising out of any such use of or any modification of the Instruments of Service (including without limitation claims arising in part from Varitone's own negligence, and/or claims arising in strict liability), except where such claim is found by a court or forum of competent jurisdiction to have arisen solely from Varitone's own negligence or willful misconduct. Varitone and its consultants shall be entitled to keep record copies of the Instruments of Service for their files.

SECTION SEVEN TERMINATION OF AGREEMENT

A. Either Architect or Owner may, on thirty (30) days' prior written notice to the other party, terminate this Agreement for reason of noncompliance with any of the provisions of this Agreement by the other party.

B. In the event of termination, Architect shall be entitled to payment for the hours incurred at the rates indicated for any and all work performed as of the date of the termination.

C. If the Owner fails to make payments to Architect in accordance with this Agreement, such failure shall be considered substantial nonperformance and cause for termination.

D. If the Project or Architect's services are suspended for more than 90 consecutive days, Architect may terminate this Agreement by giving not less than seven days' written notice. Varitone reserves the right to retain possession of all documents until full payment for services performed has been received. Varitone shall not be held liable for any damages as a result of such withholding of documents.

SECTION EIGHT CONSTRUCTION CHANGES – COSTS AND DUTIES

A. Owner agrees to pay the cost at an hourly rate of any supplementary drawings required by reason of construction changes.

B. It is understood that Architect, under the terms of this Agreement, will review and act in an advisory capacity in connection with each construction change submitted by Owner and will prepare a letter indicating her opinion as to the acceptability and effect of each change.

SECTION NINE EFFECT OF AGREEMENT

This Agreement shall bind, and the benefits thereof shall inure to, the respective parties to this Agreement, their legal representatives, executors, administrators, successors, and assigns.

SECTION TEN EFFECT OF PARTIAL VALIDITY

The invalidity of any portion of this Agreement will not and shall not be deemed to affect the validity of any other provision.

SECTION ELEVEN
ENTIRE AGREEMENT

This Agreement shall constitute the entire agreement between the parties and any prior understanding or representation of any kind preceding the date of this Agreement shall not be binding upon either party except to the extent incorporated in this Agreement.

SECTION TWELVE
MODIFICATION OF AGREEMENT

Any modification of this Agreement or additional obligation assumed by either party in connection with this Agreement shall be binding only if placed in writing and signed by each party or an authorized representative of each party.

SECTION THIRTEEN
LIMITATION OF LIABILITY

Architect's Liability is limited to the Amount of Architect's Compensation. To the fullest extent permitted by law, and notwithstanding any other provision of this Agreement, the total liability, in aggregate, of Architect and Architect's officers, directors, members, partners, agents, employees, and Consultants, to Owner and anyone claiming by, through, or under Owner for any and all claims, losses, costs, or damages, whatsoever arising out of, resulting from, or in any way related to the Project or the Agreement from any cause or causes, including but not limited to negligence, professional errors or omissions, strict liability, breach of contract, indemnity obligations, or warranty express or implied of Architect or Architect's officers, directors, members, partners, agents, employees, or Consultants shall not exceed the total compensation received by Architect under this Agreement.

SECTION FOURTEEN
CLAIMS AND DISPUTES

The Owner and Architect shall commence all claims and causes of action against the other and arising out of or related to this Agreement, whether in contract, tort, or otherwise, in accordance with the requirements of the binding dispute resolution method per this section, within the period specified by applicable law, but in any case not more than 10 years after the date of Substantial Completion of the Work. The Owner and Architect waive all claims and causes of action not commenced in accordance with this Section.

To the extent damages are covered by property insurance, the Owner and Architect waive all rights against each other and against the contractors, consultants, agents, and employees of the other for damages, except such rights as they may have to the proceeds of such insurance. The Owner or the Architect, as appropriate, shall require of the contractors, consultants, agents, and employees of any of them, similar waivers in favor of the other parties enumerated herein.

The Architect and Owner waive consequential damages for claims, disputes, or other matters in question, arising out of or relating to this Agreement. This mutual waiver is applicable, without limitation, to all consequential damages due to either party's termination of this Agreement.

Any claim, dispute or other matter in question arising out of or related to this Agreement shall be subject to mediation as a condition precedent to binding dispute resolution. If such matter relates to or is the subject of a lien arising out of the Architect's services, the Architect may proceed in accordance with applicable law to comply with the lien notice or filing deadlines prior to resolution of the matter by mediation or by binding dispute resolution.

The Owner and Architect shall endeavor to resolve claims, disputes and other matters in question between them by mediation, which, unless the parties mutually agree otherwise, shall be administered by the American Arbitration Association in accordance with its Construction Industry Mediation Procedures in effect on the date of this Agreement. A request for mediation shall be made in writing, delivered to the other party to this Agreement, and filed with the person or entity administering the mediation. The request may be made concurrently with the filing of a complaint or other appropriate demand for binding dispute resolution but, in such event, mediation shall proceed in advance of binding dispute resolution proceedings, which shall be stayed pending mediation for a period of 60 days from the date of filing, unless stayed for a longer period by agreement of the parties or court order. If an arbitration proceeding is stayed pursuant to this section, the parties may nonetheless proceed to the selection of the arbitrator(s) and agree upon a schedule for later proceedings.

The parties shall share the mediator's fee and any filing fees equally. The mediation shall be held in the place where the Project is located, unless another location is mutually agreed upon. Agreements reached in mediation shall be enforceable as settlement agreements in any court having jurisdiction thereof.

If the parties do not resolve a dispute through mediation pursuant to this Section, the method of binding dispute resolution shall be Arbitration. Unless the parties mutually agree otherwise, Arbitration shall be administered by the American Arbitration Association in accordance with its Construction Industry Arbitration Rules in effect on the date of this Agreement. A demand for arbitration shall be made in writing, delivered to the other party to this Agreement, and filed with the person or entity administering the arbitration.

A demand for arbitration shall be made no earlier than concurrently with the filing of a request for mediation, but in no event shall it be made after the date when the institution of legal or equitable proceedings based on the claim, dispute or other matter in question would be barred by the applicable statute of limitations. For statute of limitations purposes, receipt of a written demand for arbitration by the person or entity administering the arbitration shall constitute the institution of legal or equitable proceedings based on the claim, dispute or other matter in question.

The foregoing agreement to arbitrate, and other agreements to arbitrate with an additional person or entity duly consented to by parties to this Agreement, shall be specifically enforceable in accordance with applicable law in any court having jurisdiction thereof.

The award rendered by the arbitrator(s) shall be final, and judgment may be entered upon it in accordance with applicable law in any court having jurisdiction thereof.

Either party, at its sole discretion, may consolidate an arbitration conducted under this Agreement with any other arbitration to which it is a party provided that (1) the arbitration agreement governing the other arbitration permits consolidation; (2) the arbitrations to be consolidated substantially involve common questions of law or fact; and (3) the arbitrations employ materially similar procedural rules and methods for selecting arbitrator(s).

Either party, at its sole discretion, may include by joinder persons or entities substantially involved in a common question of law or fact whose presence is required if complete relief is to be accorded in arbitration, provided that the party sought to be joined consents in writing to such joinder. Consent to arbitration involving an additional person or entity shall not constitute consent to arbitration of any claim, dispute or other matter in question not described in the written consent.

The Owner and Architect grant to any person or entity made a party to an arbitration conducted under this Section, whether by joinder or consolidation, the same rights of joinder and consolidation as the Owner and Architect under this Agreement.

The provisions of this Section shall survive the termination of this Agreement.

SECTION FIFTEEN
ASSIGNMENT OF RIGHTS

The rights of each party under this Agreement are personal to that party and may not be assigned or transferred to any other person, firm, corporation, or other entity without the prior, express, and written consent of the other party.

ARCHITECT

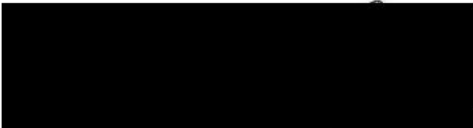

September 17, 2024
DATE

OWNER

DATE

EXHIBIT A

PROFESSIONAL SERVICES FEE SCHEDULE | 2024

PERSONNEL	Hourly Rate
Principal Architect	\$160.00
Project Architect	\$145.00
Project Manager	\$140.00
Lead Designer	\$140.00
Interior/Architectural Designer	\$120.00
Senior Drafter	\$110.00
Intern	\$95.00
Project Administration	\$85.00
Drafter	\$85.00

REIMBURSABLE EXPENSES FEE SCHEDULE

ITEM	COST
Plotting –	
24x36 BW	\$2.40
30x42 BW	\$3.60
24x36 Color	\$4.80
30x42 Color	\$7.20
11x17 Color Copy	\$1.40
Mileage	As listed by IRS on date of travel (note: travel to locations within a 15-mile radius of the Varitone offices will not be charged)
Postage	At Cost
Per Diem for Full Day Travel	\$79
Lodging	At Cost (note: hotel lodgings to be AAA 3-star or diamond minimum, or approved equal)

Fees listed are valid for a period of up to two years from date of signed Contract.

EXHIBIT B ARCHITECTURAL SERVICES

PROJECT DESCRIPTION

Varitone Architecture acknowledges receipt of the Request for Proposal from Cumberland Community Events Center (CCEC) and recognizes the project background, description, and criteria requirements for proposing parties. Critically, Varitone acknowledges the building's historic nature and the requirements associated with that status, including conformance to the Secretary of the Interior's Standards for Rehabilitation & Guidelines for Rehabilitating Historic Buildings. The project team comprises designers experienced with these guidelines, historic projects, and the local Landmarks Commission process.

Our proposal centers around making the necessary improvements to obtain a certificate of occupancy so the facility can be used as quickly as possible. The intended uses are private events and non-profit activities and programs; from a building code perspective, that likely means the space will be evaluated as an assembly use and that improvements to the building will be centered on the code-required upgrades required for assembly-type spaces. With that in mind, our project scope assumes that architectural scope will be minimized and that the goals of the project include providing required accessibility, egress, utilities, and restroom facilities in order to get the Center functional while maintaining as much of the open floor plan as possible.

SCOPE OF SERVICES

To assist you in understanding the scope of services and costs, we've broken down the project into distinct phases. In practice, the borders between phases tend to overlap and blur. Fees assigned to one phase may be moved to another to accommodate the fluid design process.

1. Schematic Design
2. Design Development

Your scope of services outlines our recommended approach and is slightly different from your RFP's.

Notable between our recommended approach and the RFP include:

- Additional meetings. We estimate this project to require a minimum of 6 meetings, accounting for project kick-off, design iterations, review of DD documents, the site walks with consultants and budgetary pricing reviews. The RFP requested two meetings in total.
- The natural consequence of your baseline RFP only having two meetings is that the design team cannot discover programmatic requirements to the detail required for the design development documents you want. Based on the written RFP scope and your follow-up feedback, we want to emphasize that your baseline scope will not get you an estimate of probable construction costs in the neighborhood of the 10% accuracy you are targeting. Our recommended scope has corrected that and provides sufficient time for the design team to help you review and finalize the parts and pieces of your project--everything from finishes, power requirements for the event space, lighting and plumbing fixtures, etc.
- SD budgetary pricing. Depending on the scale and scope of the project, as well as project budget constraints, it may be beneficial to do a budgetary estimate at the end of SD, as well as another round at the end of DD. We find that an early SD-level budgetary pricing exercise establishes very early on--and before too much money is spent on design fees--if the project is financially viable as conceived, if it needs to be re-envisioned, or even if it needs to be tabled while further fundraising is done.
- DD documents are specifically defined in our proposal as a percentage of the work required to permit and construct the project. This was done so that a target level of detail is planned for in this phase, resulting in an estimate of probable construction costs that will more closely align with the level of surety you are targeting. This may or may not align with the board's vision for this document set or with other proposing firms' scope.

1. Schematic Design

Schematic Design (SD) represents the work's earliest, most iterative stages. Here, we gather information regarding your space: What are the existing conditions, what are your goals, and how does that translate into your space plan? This is integrated with exploration of your programmatic elements and code research to ensure that the resulting design is functional, safe, and conforms to your project's practical and aesthetic requirements.

1. Programming. The 2021 Schematic Design documents need to be reviewed against the current goal of making sufficient improvements to the existing building and site to make the building occupiable. Varitone's scope for this proposal is limited to review of the existing building programming, including elements previously planned for future additions that may need to be moved to the existing building.
2. Code Analysis. Research to establish relevant code requirements (Oregon Structural Specialty Code and the Albany Development Code) for planned building and site improvements.
 - Coordination with the City as required to confirm code interpretations.
 - Limited site verification as required to address specific code concerns established during code analysis. Varitone will leverage our existing 3D model, drafted plans, and documentation from previous work with the Cumberland Community Events Center .
3. Annotated schematic-level drawings of the following views will be produced:
 - Architectural site plan
 - Demolition plan
 - New construction plan
4. Once the schematic drawings are approved, Varitone will have Owner selected and contracted engineers review the design and walk the site with them. We have included time for coordination with your engineers in our scope. From there, they will provide a preliminary narrative and/or sketches for SD Budgetary Pricing.
5. Budgetary pricing. Varitone will coordinate with your general contractor as they prepare an estimate of probable construction costs based on schematic design documents. This includes responding to questions, reviewing alternates, and value engineering (VE). Varitone's coordination time during budgetary pricing is capped at five (5) hours of personnel time.
6. Up to three (3) meetings, one reserved for reviewing budgetary pricing and evaluating VE options. After each meeting, minor revisions (affecting 15% or less of the work) are expected. Should major changes require additional schemes, design alternatives, perspectives, or other materials be required, these services may be provided as an Additional Design Service.

2. Design Development

Design Development (DD) represents the transition to technical documents—what will become your Construction/Contract Documents (CD's) in the project's next phase. CDs are the documents used for permitting and constructing the project and are not included in this scope of service. Problem-solving and resolution of design is still in-progress and directly informs the documents. Final DD drawings should reflect anywhere from 50-75% of Construction Documents, depending on how many design iterations occur during the DD phase. Not all portions of the design will be equally developed—some may be close to their final, permit-ready versions, while others will require intensive work during the CD phase.

1. Design Development level drawings of the following views will be produced:
 - Architectural site plan
 - Demolition plan
 - New construction plan
 - Power and data diagram
 - Reflected ceiling plan. The reflected ceiling plan will have annotations outlining heating/cooling zones and any owner-provided performance requirements, such as heating/cooling zones, acceptable areas for placement of mechanical units, and desired thermostat locations. These notes are not intended to be complete performance requirements

but are meant as assistance to the general contractor's design-build contractor.

- Finish plan. Finishes will be described in general categories
 - Interior elevations of new work
 - Exterior elevations (as required for new work)
 - Schedules: plumbing and lighting basis of design
2. Coordination with Owner's engineers.
 3. Budgetary pricing. Varitone will coordinate with your general contractor as they prepare an estimate of probable construction costs. This includes responding to questions, reviewing alternates, and value engineering (VE). Varitone's coordination time during budgetary pricing is capped at five (5) hours of personnel time.
 4. Up to three (3) meetings, one reserved for reviewing budgetary pricing and evaluating VE options. After each meeting, minor revisions (affecting 15% or less of the work) are expected. Should major changes require additional schemes, design alternatives, perspectives, or other materials be required, these services may be provided as an Additional Design Service.

EXCLUSIONS, ASSUMPTIONS AND QUALIFICATIONS

1. Site verification does not include exploration of hidden conditions such as wall or ceiling assembly composition.
2. Review of 2021 Schematic Design documents for future additions is excluded from scope, though can be folded into the proposed Schematic Design process on a time and materials basis at your written request.
3. Per Owner direction, consultants and their fees are excluded from scope. We have, however, provided estimates for these consultant services to assist you in your planning.
4. Architectural services related to permitting and constructing the project are excluded from scope.
5. Mechanical, Electrical, and Plumbing (MEP) are assumed to be design-build by your contractor. Varitone and its consultants are not obligated to verify existing MEP conditions or report on the impact of our scope of service on existing or new MEP systems. However, it is possible that in the course of work, Varitone and its consultants may mention or include potential MEP programmatic requirements to assist the general contractor in their work; the inclusion of said items in our work product is at the sole discretion of Varitone.
6. Assistance rendered to the Owner and their Contractors in preparing budgets and/or estimating the cost of the work represents Varitone's judgment as a design professional familiar with the construction industry. However, It is recognized that neither Varitone nor the Owner has control over the cost of labor, materials/equipment, the Contractor's methods of determining bid prices, the competitive bidding process, or market conditions. Accordingly, Varitone cannot and does not warrant or represent that bids or negotiated prices will not vary from the Owner's budget, estimate of probable construction costs, or from any budgetary estimate exercises Varitone participates in. Varitone, therefore, shall be under no obligation to design the Project so that it may be constructed within any specific budget.
7. Should major changes require additional schemes, design alternatives, perspectives, or other materials, these services may be provided as an Additional Design Service
8. It is assumed that CCEC will designate a representative who can render decisions and provide information in a timely fashion, allowing the Project to proceed in general conformance to the proposed project schedule. Substantial delays in communication, scheduling of meetings, and decision-making may result in project delays that can trigger additional services, depending on the impact on overall work and scope.

9. Other services related to the Project but not specifically included under the outlined Scope of Services between Varitone and CCEC are excluded. Unexpected conditions that require design revisions may be considered additional services contingent upon the extent of the impact on the overall design. A change in the original scope of services or additional work requested, as well as any rework of or change in previously approved work, are also excluded.

10. This proposal and listed compensation for the scope of work described is valid for up to 90 days from date hereof.



PO Box 986 • Albany, OR 97321-0371 • [REDACTED]

Joel Orton
[REDACTED]

Cell: +19084135846

Job Address:

1400 Santiam RD SE
Albany, OR 97321

Print Date: 10-23-2025

R.O.M. Cumberland Church Project

Rough Order of Magnitude cost exercise for the Cumberland Church Project. Below are estimated costs to complete the following goals:

- ADA accessibility and pedestrian access from two separate locations to Santiam and Pine Street
- Front main entrance connecting to sidewalk on Santiam
- Installation of natural gas service, furnaces, heat pumps, and ducting
- Establish electrical service via a 400A service (to accommodate planned future expansion)
- Wire the building for lighting, receptacles, and equipment. Also to include emergency egress lighting, night lighting (interior and exterior)
- Build out low voltage items like phone / data, WIFI, and fire alarm panel (required with sprinklers)
- Tie into (what appears to be via Infohub) existing city water meter location (1" meter) and 6" sewer lateral
- Install plumbing and fixtures for two single occupant restrooms a hand sink, and a prep sink
- Build infrastructure for fire sprinkler system. System sized and designed for future expansion
- Add structural steel framing (presuming interior footings required) to secure openings at both ends of center room
- Insulate walls, ceilings, and underfloor. Walls to have internal air barrier system to allow wood siding to dry
- Hang and finish drywall throughout interior
- Interior carpentry; mouldings, millwork, door fabrication, etc. Copious budget for labor and material
- Paint interior / finish walls, ceilings, doors, mouldings and millwork
- Obtain certificate of occupancy for building to begin use as a community center

Notes:

- The required infrastructure for a commercial building takes a decent amount of interior space. Items such as the electrical distribution panel, fire panel, communication and network equipment, and sprinkler riser assembly will all need to find a home within the confines of the church. This is much akin to attempting to stuff 10 lbs. of flour in a 5 lb bag - especially when trying to preserve interior space and architecture. I would advocate for an addition to the east end of the building to serve as home for the above listed infrastructure items. The addition could also serve as a home for the restrooms until Phase II is completed. This approach would create more assembly space and preserve the historic architecture from being covered over for restrooms. An addition on the east end should allow the installation of the fire department connection directly on the building.
- The budget for the supply tap is based on the ability to tie into the Pine St city water supply. If the public works requires a Santiam Road tie-in, the cost will increase due to the need for traffic management.

Soft Costs

Soft Costs General Conditions					
Items	Description	Unit Cost	Qty/Unit	Unit Price	Price
General Labor Buildertrend Flat Rate	Cleanup, materials management, hand excavation, sub-contractor assistance, etc.	\$68.00	600	\$78.20	\$46,920.00
Supervision Labor 02.00 - Supervision Labor	Project supervision labor	\$100.00	160	\$115.00	\$18,400.00
Refuse Management 01.42 - 14 Yard Dumpster	GC provided 14 yard roll-off dumpster. Flat rate fee per dump. No rental fee.	\$500.00	4	\$575.00	\$2,300.00
Equipment Rental 01.25 - Equipment Rental	Allowance for misc. rental	\$1,500.00	1	\$1,725.00	\$1,725.00
Portable Sanitation 01.15 - Portable Sanitation	Best Pots sanitation service. 1 unit monthly rental	\$130.00	6	\$149.50	\$897.00
General Conditions Total:					\$70,242.00
Soft Costs Engineering / Consulting / Special Inspections					
Items	Description	Unit Cost	Qty/Unit	Unit Price	Price
Special Inspections 01.60 - Special Inspections	Estimated cost of third-party inspection services: structural welding, epoxied anchors, soil compaction, etc.	\$2,200.00	1	\$2,530.00	\$2,530.00
Sprinkler System Engineering 01.05 - Engineering	Estimated cost of fire sprinkler system engineering	\$2,800.00	1	\$3,220.00	\$3,220.00
Engineering / Consulting / Special Inspections Total:					\$5,750.00
Soft Costs Public Works & SDC Fees					

Items	Description	Unit Cost	Qty/Unit	Unit Price	Price
Water Service 03.35 - Public Works Fees	Estimated fees for installation of 1" meter to pre-existing (per Infohub) tap on Santiam. SDC Fee: \$7,910 Public Works Fee: \$3,315 Connection Charge: \$19,560 based on 195' of street frontage	\$30,785.00	1	\$30,785.00	\$30,785.00
Sanitary Sewer 03.35 - Public Works Fees	Estimated fees for hook-up to pre-existing (per Infohub) 6" sewer lateral on lot. SDC Fees: \$6,022 first six fixtures + \$1,004 ea. additional fixture (6 proposed fixtures) Connection Charges: \$19,560	\$25,582.00	1	\$25,582.00	\$25,582.00
Storm Connection 03.35 - Public Works Fees	Estimated fees for hook-up to storm drain collector. Note: more research needed. Previous storm drain permit notes a "temporary connection" to gutter collector. Unsure what fees may have already been assessed. SDC Fees: \$515 Connection Charge: \$21,125	\$21,640.00	1	\$21,640.00	\$21,640.00
Transportation SDC Fee 03.35 - Public Works Fees	Estimated amount	\$26,100.00	1	\$26,100.00	\$26,100.00
Sprinkler Supply 03.40 - Utility Fees	Hot tap of city water supply pipe (Pine ST) for 4" sprinkler feed	\$5,000.00	1	\$5,750.00	\$5,750.00
Public Works & SDC Fees Total:				\$109,857.00	

Soft Costs					
Permits					
Items	Description	Unit Cost	Qty/Unit	Unit Price	Price
Building Permit 01.10 - Permits & Fees	Estimated building permit cost	\$5,000.00	1	\$5,750.00	\$5,750.00
Mechanical (HVAC) Permit 01.13 - Mechanical Permit	City of Albany mechanical permit fees	\$1,017.00	1	\$1,169.55	\$1,169.55
Plumbing Permit 01.10 - Permits & Fees	City of Albany plumbing permit fees	\$537.60	1	\$618.24	\$618.24
Permits Total:				\$7,537.79	

Soft Costs Total: \$193,386.79

Site Work

Items	Description	Unit Cost	Qty/Unit	Unit Price	Price
Concrete / Asphalt Cutting 04.35 - Concrete Cutting	Allowance for curb and sidewalk concrete cutting, and street asphalt cutting	\$3,400.00	1	\$3,910.00	\$3,910.00
Exterior Railings 05.15 - Welding & Fabrication	- Guards / handrails for two ramps - Handrail for Pine St. steps - Decorative railing and handrails for main entrance	\$30,000.00	1	\$34,500.00	\$34,500.00
Excavation 03.05 - Excavation	Excavation allowance for: - Utility trenching (power, comms, fire sprinkler supply pipe, water supply, sewer, and storm water. - Sprinkler system vault - Scrape, place rock and compact for ramps and sidewalks	\$48,000.00	1	\$55,200.00	\$55,200.00
Concrete Work 04.00 - Concrete	Form, pour, and finish concrete for the following: - 3 landings - 2 ramps - 2 sets of steps - section of removed curbs and sidewalks	\$56,000.00	1	\$64,400.00	\$64,400.00

Site Work Total:**\$158,010.00**

Mechanical

Items	Description	Unit Cost	Qty/Unit	Unit Price	Price
Ventilation 09.00 - HVAC	Remote bath fans. Equipment ducting and terminations	\$686.00	1	\$788.90	\$788.90
HVAC 09.00 - HVAC	Equipment and labor to install new gas fired furnaces, outdoor cooling units, economizer, and fresh air ventilation. Also including full underfloor ducting system	\$48,000.00	1	\$55,200.00	\$55,200.00

Mechanical Total:**\$55,988.90**

Electrical

Items	Description	Unit Cost	Qty/Unit	Unit Price	Price
Electrical Work 10.00 - Electrical	400 amp service, 200 amp distribution panel in church. Future 200 amp feeder for addition. Wire in interior / exterior lighting and receptacle circuits. Power for HVAC equipment, comms, and fire panel. Night lighting circuit on timer controller	\$48,000.00	1	\$55,200.00	\$55,200.00
Light Fixture Package 10.05 - Lighting	Interior & exterior light fixtures	\$18,000.00	1	\$20,700.00	\$20,700.00
Fire Alarm 10.00 - Electrical	Supply and installed monitored (fire sprinkler flow switch) alarm system. This is a minimum code requirement for a fire sprinkler system. Note this requires a dedicated land line and a monthly monitoring service.	\$9,700.00	1	\$11,155.00	\$11,155.00

Items	Description	Unit Cost	Qty/Unit	Unit Price	Price
Low Voltage 10.00 - Electrical	Establish and install phone / data / wifi repeaters	\$5,200.00	1	\$5,980.00	\$5,980.00

Electrical Total: **\$93,035.00**

Plumbing

Items	Description	Unit Cost	Qty/Unit	Unit Price	Price
Plumbing 08.00 - Plumbing	Labor and material to rough in waste and supply lines. Furnish and install fixtures.	\$14,500.00	1	\$16,675.00	\$16,675.00

Plumbing Total: **\$16,675.00**

Fire Sprinklers

Items	Description	Unit Cost	Qty/Unit	Unit Price	Price
Fire Sprinkler Installation 08.25 - Fire Sprinkler System	Estimated cost of installation of fire suppression system (note: system designed and installed to accommodate future addition)	\$44,000.00	1	\$50,600.00	\$50,600.00

Fire Sprinklers Total: **\$50,600.00**

Building Interior

Building Interior Framing & Structural					
Items	Description	Unit Cost	Qty/Unit	Unit Price	Price
Structural Steel Fabrication and Installation 05.15 - Welding & Fabrication	Allowance for construction and installation of structural steel assemblies at pocket door locations	\$100.00	160	\$115.00	\$18,400.00

Items	Description	Unit Cost	Qty/Unit	Unit Price	Price
Structural Steel Materials 05.20 - Structural Steel Materials	Estimated materials cost	\$2,600.00	1	\$2,990.00	\$2,990.00
Interior Framing 05.05 - Framing Labor	Contractor labor to build walls, build air-gap detail, and complete all other rough framing needs	\$68.00	320	\$78.20	\$25,024.00
Materials: Lumber & Sheet Goods 05.10 - Framing Material	Lumber, plywood, glulam beams, etc.	\$4,500.00	1	\$5,175.00	\$5,175.00
Materials: Fasteners, Concrete, & Incidentals 05.12 - Brackets & Fasteners	Allowance for fasteners, concrete, rebar, brackets, and incidentals	\$1,640.00	1	\$1,886.00	\$1,886.00
Framing & Structural Total:					\$53,475.00

Building Interior Walls & Ceilings					
Items	Description	Unit Cost	Qty/Unit	Unit Price	Price
Insulation 11.00 - Insulation	Insulate floor, walls, and ceilings. Spray foam (2" depth) for walls, blown loose fill fiberglass at flat ceiling, batts everywhere else.	\$21,750.00	1	\$25,012.50	\$25,012.50
Drywall 11.05 - Drywall	Drywall, installation, and finishing	\$24,000.00	1	\$27,600.00	\$27,600.00
Painting Labor 14.10 - Painting Labor	Contractor labor to prime, and apply two coats of finish to all drywall surfaces	\$55.00	300	\$63.25	\$18,975.00
Paint & Supplies 14.20 - Paint & Painting Supplies	Primer, paint, and disposables	\$1,896.00	1	\$2,180.40	\$2,180.40
Walls & Ceilings Total:					\$73,767.90

Building Interior Floorcovering					
Items	Description	Unit Cost	Qty/Unit	Unit Price	Price
Wood Floors 15.05 - Hardwood	Fill in areas of missing flooring. Sand and finish 2,400 sqft of flooring - 3 coats of Swedish finish	\$15,125.00	1	\$17,393.75	\$17,393.75

Floorcovering Total:

Building Interior Doors & Glazing					
Items	Description	Unit Cost	Qty/Unit	Unit Price	Price
Installation Labor Buildertrend Flat Rate	Contractor labor to install doors and hardware	\$68.00	76	\$78.20	\$5,943.20
Exterior Door 06.10 - Exterior Doors	New SE entry door and hardware allowance	\$2,850.00	1	\$3,277.50	\$3,277.50
Interior Doors & Hardware Buildertrend Flat Rate	Interior door and code compliant hardware allowance. Figuring a stacked 5 panel 1 pc. molded door	\$6,812.00	1	\$7,833.80	\$7,833.80
Doors & Glazing Total:					\$17,054.50

Building Interior Moulding & Millwork					
Items	Description	Unit Cost	Qty/Unit	Unit Price	Price
Millwork Installation Labor 12.00 - Trim Carpentry Labor	Contractor labor to install mouldings and millwork. This is a general allowance that could cover fabrication of large pocketing doors, and perhaps some ornate detailing to the center main area of the structure. A coffered ceiling would be a nice addition....also wainscot, crown, etc.	\$68.00	800	\$78.20	\$62,560.00
Materials 12.05 - Molding & Millwork	General materials allowance for interior moulding and millwork finishes	\$18,000.00	1	\$20,700.00	\$20,700.00
Moulding & Millwork Total:					\$83,260.00

Building Interior Casework & Countertops					
Items	Description	Unit Cost	Qty/Unit	Unit Price	Price
Countertops 12.35 - Solid Surface Countertops	Laminate floating countertop allowance	\$1,680.00	1	\$1,932.00	\$1,932.00
Casework & Countertops Total:					\$1,932.00

Building Interior Appliances & Accessories					
--	--	--	--	--	--

Items	Description	Unit Cost	Qty/Unit	Unit Price	Price
Restroom Accessories 16.05 - Appliances	Tissue dispenser, paper towel dispenser, trash receptacle, grab bars, mirrors	\$1,350.00	1	\$1,552.50	\$1,552.50
Fire Extinguisher Cabinets & Extinguishers 16.05 - Appliances	Recessed cabinets and new 10lb extinguishers	\$370.00	2	\$425.50	\$851.00
Appliances & Accessories Total:					\$2,403.50
Building Interior Total:					\$249,286.65

Total Price: \$816,982.34



Project Evaluation Grid: 1400 Santiam Road SE

Request: \$109,100

	Item	Description	Staff Analysis/Comments
<i>Overall Goals</i>			
A)	<p>CARA Goal & Objectives: The purpose of this CARA Plan is to eliminate blighting influences found in the CARA, to implement goals and objectives of the City of Albany Comprehensive Plan, and to implement development strategies and objectives for the CARA. The goal and objectives for the CARA have been defined as follows:</p> <p>CARA Goal: To revitalize the Central Albany Revitalization Area by implementing the Town Center Plan developed through the Central Albany Land Use & Transportation Study (CALUTS) using a citizen-driven process.</p>	<p>Does the project further the Town Center Plan?</p> <p>Which of CARA’s objectives does the project meet?</p> <p>CARA Key Objectives:</p> <ul style="list-style-type: none"> ◆ Attract new private investment to the area. ◆ Retain and enhance the value of existing private investment and public investment in the area. <p>CARA Additional Objectives:</p> <ul style="list-style-type: none"> ◆ Provide a safe and convenient transportation network that encourages pedestrian & bicycle access to and within the town center. ◆ Preserve the Historic Districts, historic resources and existing housing in the area. ◆ Create a readily identifiable core that is unique and vibrant with a mixture of entertainment, housing, specialty shops, offices, and other commercial uses. ◆ Increase residential density in the area. ◆ Encourage the development of new forms of housing and home ownership. ◆ Enhance and protect the community and environmental values of waterway corridors in the area. ◆ Provide an enriching environment and livable neighborhoods. 	<p>Yes.</p> <p>This project meets CARA's two key objectives as listed.</p> <p>Addition objectives met:</p> <p>Historic preservation Readily identifiable core Enriching environment</p>
B)	<p>CARA Planned Projects</p>	<p>Which project category and activity in the UR Plan does this project fulfill? (See CARA Project Activities document, or Table 2 of the UR Plan and Report.)</p>	<p>Commercial Building Rehabilitation, Transition Areas Redevelopment</p>
C)	<p>Development Pattern (Highest and Best Use)</p>	<p>Does it achieve desired land use (e.g., mixed-use, higher density) and/or transportation objectives (e.g., Esplanade, pedestrian-friendly areas)? Is the proposed project desired in this location and the highest and best use of the property?</p>	<p>Zone: Main Street</p> <p>Yes, proposed project falls within options for highest and best use for this property.</p>
D)	<p>Blight</p>	<p>Would it remedy a severely blighted building? How? Does the project utilize a vacant space?</p>	<p>Yes, project supports use of a currently vacant space.</p>

E)	Preservation	Would it rehabilitate or sensitively redevelop a historic property?	Yes.
F)	Vitality/People Attractor	Does the general public benefit (i.e. restaurant, carousel, something they can go to; does the project enhance the public's experience of the space; is it a business we are seeking)?	Yes, project creates an event center.
G)	Retail Hotspot (First Avenue between Lyon and Calapooia)	Is the project located in the Retail Hotspot? If so, will the first floor use be active retail, as recommended in the Retail Refinement Plan?	No.
H)	Sustainable Building	Will the building be built using sustainable practices including LEED or others?	Not addressed in applicaiton.
I)	Residential	Is there a residential component? How many units?	No.
<i>Economic Development</i>			
J)	Bring new business to Albany	Will a new business open or come to Albany as a part of this project?	No, but will facilitate opening of a non-profit event center.
K)	Job Creation	Will the project create additional jobs? How many, what types and what salary level?	1 part time position. Salary not indicated in application.
L)	Local Labor and Materials	Has applicant specifically called out a commitment to use a certain percent or amount of local labor and/or materials?	Not specifically called out in application.
<i>Financial</i>			
M)	Ratio	Proposed public funds Private funds % of CARA Investment	Applicant requesting 12% of total project costs for this phase.
N)	Financial Impacts	What are the financial risks and/or financial benefits to CARA?	Reimbursement based-grant; low financial risk. Benefits through increased value.
O)	Gap	What is the "Gap" or need of the developer?	\$109,100
P)	Private Risk	What is the risk for the developer? What is their skin in the game?	\$768,200
Q)	CARA/City funds	Has the project received other CARA/City funding in the past?	No.
R)	Tax Increment ROI	Is the ROI on this project less than 5 years, less than 7 years?	Due to non-profit status, ROI through tax-increment is not imminent.



CARA GRANT APPLICATION

1. APPLICANT

Name: Joshua Mitchell

Mailing Address: [REDACTED]

[REDACTED] Zip Code: [REDACTED]

Title: owner Phone Number: [REDACTED]

E-mail Address: [REDACTED]

2. BUSINESS/BUILDING INFORMATION

Legal Business Name: River City Design & Build LLC

Number of Years in Operation: 3

Legal Form: Sole Proprietorship Partnership Corporation S-Corp LLC
 Profit Nonprofit

EIN: [REDACTED]

In which state are the incorporation and/or organization documents filed? Oregon

Have you ever filed for bankruptcy? Yes No

Project Address (if different than mailing address): 1550 Salem Av SE Albany, Oregon

Property Tax Account Number: 381018

Is the building a historic contributing resource? Yes No

If so, is it on the historic property-tax freeze? Yes No

3. OWNER OF PROPERTY (if not applicant)

Name in which title is held: Mitchell 1550 LLC

Contact Name: Josh Mitchell

Mailing Address: [REDACTED]

[REDACTED] Zip Code: [REDACTED]

Phone Number [REDACTED]

4. AUTHORIZATION TO UNDERTAKE WORK:

If the applicant is not the owner of the property, provide written evidence that the owner authorizes this work to be undertaken. (Typically this is in the form of a lease or other written permission.)

5. DESCRIPTION OF PROJECT *Please give a comprehensive description of project.*

River City Design Build has acquired an 1,800-square-foot commercial building on approximately 0.5 acres within the greater downtown corridor. Built prior to 1964, the structure is sound but currently underutilized, with aging exterior materials, gravel yard areas, and limited street presence along Salem Avenue.

The project includes new insulated metal siding, a defined covered entry with expanded lobby space, updated signage, improved lighting, and full site paving to replace gravel. Security and lighting upgrades will address ongoing issues with trespassing, vandalism, and dumping while improving overall safety.

The building will support approximately 1,200 square feet of office space and 600 square feet of shop and storage, enabling expanded operations and long-term occupancy. These improvements will create a visible transformation, reduce blight, and bring a key property into productive use.

By reinvesting in an existing structure, the project aligns with CARA's goals for revitalization, safety, and economic activity within the downtown corridor.

6. TIMELINE FOR COMPLETION OF PROJECT: May 2027

7. PROJECT COSTS

ESTIMATED COST OF PROJECT: \$ 100,907

ESTIMATED VALUE OF PROJECT UPON COMPLETION: \$ 350,000

Basis for valuation and value upon completion: The overall curb appeal and energy efficiency will be greatly enhanced including the functionality and removing a neighborhood blight

SOURCES FOR PROJECT:

Owner/Company Contribution	<u>\$ 29,800</u>
Bank (estimated)	<u>\$ 0</u>
Other private funds (please specify)	<u>\$ 0</u>
Other governmental (please specify)	<u>\$ 0</u>
CARA (proposed)	<u>\$ 71,107</u>
TOTAL SOURCES	<u>\$ 100,907</u>

Is your funding for these: available today applied for unknown at this time

USES FOR PROJECT:

Land and/or Building Acquisition	<u>\$ 0</u>
Soft Costs (architectural, engineering, financing, and legal fees, and other pre- and post-construction expenses.) *	<u>\$ 7,250</u>
Construction Costs *	<u>\$ 93,657</u>
Tenant Improvements	<u>\$ 0</u>
Machinery/Equipment/Installation Costs	<u>\$ 0</u>
Working Capital	<u>\$ 0</u>
Other (please specify)	<u>\$ 0</u>
TOTAL USES	<u>\$ 100,907</u>

*Please provide a detail of Soft Costs and of Construction Costs (Please attach).

8. PREPARATION OF COST ESTIMATES

Who prepared your cost estimates? Josh Mitchell

(If applicant prepared their own estimate, verification may be required. **Please attach minimum of two bids, preferably three.**)

Mailing Address: [Redacted]
Phone Number: [Redacted] E-mail Address: [Redacted]

9A. EXPLAIN WHY CARA FUNDING IS NECESSARY TO INSURE PROJECT COMPLETION.

(Please provide a description of the financial gap requiring CARA assistance.)

CARA funding is necessary to make the planned rehabilitation and site improvements financially feasible at this time. The total project cost is estimated at approximately \$101,000, which represents a significant investment for a small, locally operated business that has only recently secured the property.

Since acquiring the building earlier this year, we have already committed substantial internal resources to stabilize and activate the site. This work has included debris removal, interior office improvements (paint and flooring), minor electrical upgrades, insulation improvements, and HVAC repairs. These efforts have allowed us to begin occupying and utilizing the building, demonstrating both our commitment to the property and our ability to execute improvements.

However, the remaining scope—particularly exterior rehabilitation, parking improvements, and safety upgrades—extends beyond what we can reasonably complete in the near term without assistance. CARA funding would allow these critical improvements to be completed now, rather than delayed or phased over several years.

By helping close this financial gap, CARA funding will leverage significant private investment already made, improve safety and site functionality, and accelerate the visible rehabilitation of an aging industrial property within the revitalization district. This project will contribute to corridor improvement, support local economic activity, and align with the City's broader goals for reinvestment and community development.

9B. IF YOU DON'T RECEIVE THE FUNDS, WHAT COMPONENTS WILL BE DROPPED? WOULD THE PROJECT GET DONE WITHOUT CARA FUNDS? (Please provide a detailed explanation.)

If CARA funding is not awarded, the project would need to be scaled back and completed incrementally over time. While we would continue to invest internal resources as we have since acquiring the property, major components such as exterior siding replacement, parking improvements, entry upgrades, lighting, and security enhancements would likely be delayed.

To date, we have already made meaningful progress using internal funds to stabilize and activate the building. However, the remaining exterior and site improvements represent a larger capital investment that is not feasible to complete in the near term without assistance.

The project would ultimately still move forward, but at a much slower pace and in phases as resources allow. CARA funding would enable us to complete these improvements now, maximizing the immediate impact on safety, functionality, and the surrounding revitalization area rather than delaying those benefits over several years.

10. WHERE ELSE HAVE YOU LOOKED FOR FUNDING?

We have not actively pursued outside funding for this project to date, as we have been advancing improvements using internal resources since acquiring the property earlier this year. The CARA program presented our first opportunity to seek external support and accelerate planned upgrades. Without this funding, we would continue making incremental improvements and consider additional funding opportunities in the future.

11. CONSIDERING THE PROJECT GOALS OUTLINED IN THIS APPLICATION, PLEASE IDENTIFY THE VALUE YOUR PROJECT BRINGS TO CARA.

River City Design Build's project advances CARA's mission by leveraging private investment to rehabilitate and reactivate an aging commercial property within the downtown corridor. Since acquiring the building, we have invested internal resources to stabilize and begin utilizing the space, demonstrating readiness and long-term commitment.

Planned improvements—including new siding, paving, entry upgrades, and enhanced lighting and security—will improve safety, functionality, and energy performance while delivering a visible reduction in blight along Salem Avenue.

As a locally owned design-build firm, we also support other downtown businesses and CARA applicants, including working on Albany Civic Theater's Oregon Main Street Grant project. This investment strengthens our ability to continue contributing to broader revitalization efforts.

CARA funding will accelerate completion, maximizing the impact of private investment and advancing the City's goals for revitalization and long-term economic vitality.

12. PLEASE OUTLINE ANY OTHER BENEFITS YOUR PROJECT PROVIDES.

(To Albany, and the area/neighborhood)

Beyond the primary improvements, this project delivers long-term benefits aligned with CARA's goals for safety, sustainability, and economic vitality. Rehabilitating an existing structure avoids demolition, reduces material waste, and improves energy efficiency through upgraded insulation and durable exterior materials.

Site improvements—including asphalt paving, lighting, and security—will enhance safety, reduce dust and runoff, and address ongoing issues such as trespassing and illegal dumping. Given the property's visibility along Salem Avenue, these upgrades will provide an immediate improvement to the corridor.

As an owner-occupied investment, the project supports long-term property stability and strengthens the local tax base. As a locally owned design-build firm actively working on downtown projects, this investment also supports our continued role in ongoing revitalization efforts.

13. HAVE YOU OR THIS PROPERTY RECEIVED CARA FUNDING AT ANY POINT IN THE PAST?

No Yes If so, amount \$ _____

FOR WHAT PROJECT(S): _____

WHEN? _____

14. ASSISTANCE REQUESTED

Total Estimated Project Costs:	\$ <u>100,907</u>
Your Total Contribution	\$ <u>29,800</u>
Total Amount Requested from CARA:	\$ <u>71,107</u>

Final payment will be based on actual costs not estimates. **Ten percent of CARA funds will be held back for final payment.**

15. BREAKDOWN OF USE OF CARA FUNDS

CARA funds can only be used for permanent improvements to the building. Please provide a breakout with specific details of how the CARA funds will be used in the project. If more space is needed, please attach a separate page.

Item	Amount	Notes
Electrical & HVAC	8,300	Lighting, cameras, electrical upgrades, ducting
Front Porch	12,462	Open beam framing, concrete patio, roof
Insulation	8,100	Exterior perimeter, attic and underfloor
Exterior	11,550	Metal siding, stone veneer, landscaping, gutters
Doorways	11,350	New front porch, patio, entry doorway
Parking	15,000	New parking area, driveways
Signage	4,345	New exterior signage (Building & Street)
TOTAL	71,107	Total should match total amount requested from CARA from line 14.

Metrics and Other Benefits

If you receive funding, you will be asked to tally the final figures on the project and certify their accuracy. Please use this space to estimate the impact of your project:

Number of Jobs Created: 1 Full-time 1 Part-Time

Certification

The Applicant understands and agrees to the following conditions:

1. Any physical improvements proposed must be approved by the Albany Revitalization Area Agency (ARA) and may require approval by the City of Albany Landmarks Advisory Commission or other entities. These entities may require certain changes or modifications before final approval and Commitment of Funds.
2. Any work begun before receipt of a Contract notice is ineligible for reimbursement.
3. Any work deviating from that detailed in the Contract must be preapproved in writing to be eligible for reimbursement.
4. While only proprietary information may be held in confidence outside of the public record, ARA will attempt to maintain all information provided in a confidential manner.
5. Originals of all materials prepared with ARA assistance belong to ARA and will be maintained in the public record.
6. Application must be completed in its entirety before being considered; if not, it will be returned for completion.
7. Staff is authorized to independently verify any and all information contained in this application.
8. ARA may withhold approval of this application until information satisfactory to ARA is provided.

The Applicant certifies that all information in this application and all information furnished in support of this application is given for the purpose of obtaining ARA assistance and is true and complete to the best of the Applicant's knowledge. Applicant further acknowledges the undersigned applicant(s) have read and understand CARA's privacy policy and have completed this form with accurate information.

Josh Mitchell _____

Applicant's Printed Name

Applicant's Printed Name

Applicant's Signature 

Date 3/31/26

Applicant's Signature _____

Date _____

Return application/attachments to: City of Albany c/o Sophie Adams, Economic Development Manager: sophie.adams@albanyoregon.gov



River City Design & Build			
	1305 Old Salem Rd NE		
	Millersburg, OR 97321		
	[REDACTED]		
	CCB# 246630, C#2069		
ADDRESS		ESTIMATE #	2026-1550
	River City Design & Build		
	1550 Salem Av SE		
	Albany, OR 97321		
ACTIVITY			AMOUNT
00 Description			
01 Design			\$ 2,250.00
	<i>Building design, drawings, plans</i>		
02 SDCs & Permits			\$ 5,000.00
	<i>Minimum fee (water service to 3/4" meter)</i>		
03 Demo			\$ 4,500.00
	<i>Removal of work-site debris, concrete, existing roofing/2nd story</i>		
04 Excavation			\$ -
	<i>Included in Parking Lot</i>		
05 Concrete			\$ 4,800.00
	<i>Porch and footings</i>		
06 Foundation			\$ -
07 Underfloor			\$ 396.00
	<i>Visqueen</i>		
08 Floor Frame			\$ 2,800.00
	<i>New raised floor, PT joists, 1-1/8" plywood subfloor</i>		
09 Wall Frame			\$ 5,123.00
	<i>New entryway, interior office and lobby space</i>		
10 Roof			\$ 6,000.00
	<i>New front porch cover, open beam</i>		
11 Trusses			\$ -
12 Siding			\$ 9,450.00
	<i>New metal siding, flashing, stone accent</i>		
13 Door & Trim			\$ 9,900.00
	<i>New man door, aluminum storefront entry doorway</i>		
14 Windows & Trim			\$ -
	<i>New front windows included in doorway</i>		

15 Plumbing	\$	-
16 HVAC	\$	2,300.00
<i>Additional registers for office and lobby</i>		
17 Electrical & Lighting	\$	6,000.00
<i>New electrical rough-in, finish, exterior lighting, security & cameras</i>		
18 Insulation	\$	8,100.00
<i>Exterior walls, under raised floor & roof</i>		
19 Interior Walls	\$	4,000.00
<i>Hang, mud, tape, texture</i>		
20 Cabinets & Vanities	\$	-
21 Floor Coverings	\$	2,475.00
<i>\$3.50/SF material allowance upstairs (LVP, carpet)</i>		
22 Paint	\$	3,250.00
<i>Prime, 2 color Interior</i>		
23 Landscaping & Paving	\$	2,100.00
<i>Exterior perimeter, bushes, walkway</i>		
24 Appliances	\$	-
25 Countertops	\$	-
26 Garage Door(s)	\$	1,450.00
<i>1 roll up door</i>		
27 Well	\$	-
28 Septic	\$	-
29 Gutters	\$	1,662.50
<i>New continuous gutters, downspouts</i>		
30 SITE SPECIFIC	\$	15,000.00
<i>New asphalt driveway, parking area</i>		
31 SITE SPECIFIC	\$	4,345.04
<i>New street & building signage</i>		
33 CONTINGENCY	\$	-
<i>Misc 10%</i>		
34 PROJECT MANAGEMENT	\$	-
SUBTOTAL	\$	100,901.54

New Build
1550 Salem Ave SE



Please Make Checks Payable to:
Legacy Custom Fence and Home Improvements, LLC
506 3rd Ave SE
Albany, OR 97321

River City Design & Build
1305 Old Salem Rd NE
Millersburg, OR 97321

Qty	Item # Description	Job	Unit Price	Line Total
	<u>New Build</u>			
1.00	Scope of work: Build and design, permits, demo of existing structure, complete excavation, pour porch and footings, pour foundation, floor prep, frame walls, hang roof and complete truss work, install new metal siding with stone trim accents, install man door per customer specs, install new windows according to specs. Install new HVAC system. Complete electrical rough in and finish trim, customer to select final trim, install security/security cameras. Install insulation, drywall with mud/taping/texture, complete interior painting (2 coats with primer included), install new LVP flooring and carpet in selected areas. Complete landscaping of exterior grounds and walkway. Install main roll up door, manufacture and install new continuous 5k gutters with attached downspouts, pave asphalt driveway and parking lot-including lot level and base prep. Complete final signage according to local code. Pricing includes labor, materials, delivery, and disposal.			
	<u>Cost Breakdown</u>			
1.00	<u>Design, Drafting, Plans</u>			2,400.00
1.00	<u>System Development, Planning and Zoning, Permits</u>			5,500.00
1.00	<u>Demolition</u>			5,200.00
1.00	<u>Excavation</u>			1,200.00
1.00	<u>Concrete</u>			4,900.00
1.00	<u>Foundation</u>			1,200.00
1.00	<u>Floor Prep/Crawlspace</u>			1,600.00
1.00	<u>Floor Framing-Pressure Treated Joists with minimum 1-1/8 subfloor</u>			3,400.00
1.00	<u>Framing</u>			6,200.00
1.00	<u>Roof</u>			8,000.00
1.00	<u>Siding & Trim</u>			8,900.00
1.00	<u>Door & Trim</u>			7,200.00
1.00	<u>Windows and Trim</u>			3,600.00
1.00	<u>HVAC Installations</u>			2,900.00
1.00	<u>Electrical</u>			7,200.00
1.00	<u>Insulation</u>			7,900.00
1.00	<u>Drywall</u>			5,800.00
1.00	<u>Flooring</u>			3,400.00
1.00	<u>Interior Paint</u>			3,100.00
1.00	<u>Landscaping</u>			2,600.00
1.00	<u>Garage Door Install</u>			1,750.00
1.00	<u>Gutter Install</u>			1,900.00
1.00	<u>Paving</u>			16,500.00
1.00	<u>Building Signage/Street Signage</u>			4,900.00
	*Pricing Subject to additional findings. Change order form required for all changes over \$400.			
	**50% down payment requirement upon signing of contract. Payment in full due upon completion of project scope.			

*Project Manager: Phil

Subtotal \$ 117,250.00
Sales Tax
Total \$ 117,250.00

Authorized by _____ Date _____









Project Evaluation Grid: 1550 Salem Avenue SE

Request: \$71,107

	Item	Description	Staff Analysis/Comments
<i>Overall Goals</i>			
A)	<p>CARA Goal & Objectives: The purpose of this CARA Plan is to eliminate blighting influences found in the CARA, to implement goals and objectives of the City of Albany Comprehensive Plan, and to implement development strategies and objectives for the CARA. The goal and objectives for the CARA have been defined as follows:</p> <p>CARA Goal: To revitalize the Central Albany Revitalization Area by implementing the Town Center Plan developed through the Central Albany Land Use & Transportation Study (CALUTS) using a citizen-driven process.</p>	<p>Does the project further the Town Center Plan?</p> <p>Which of CARA’s objectives does the project meet?</p> <p>CARA Key Objectives:</p> <ul style="list-style-type: none"> ◆ Attract new private investment to the area. ◆ Retain and enhance the value of existing private investment and public investment in the area. <p>CARA Additional Objectives:</p> <ul style="list-style-type: none"> ◆ Provide a safe and convenient transportation network that encourages pedestrian & bicycle access to and within the town center. ◆ Preserve the Historic Districts, historic resources and existing housing in the area. ◆ Create a readily identifiable core that is unique and vibrant with a mixture of entertainment, housing, specialty shops, offices, and other commercial uses. ◆ Increase residential density in the area. ◆ Encourage the development of new forms of housing and home ownership. ◆ Enhance and protect the community and environmental values of waterway corridors in the area. ◆ Provide an enriching environment and livable neighborhoods. 	<p>Yes.</p> <p>This project meets CARA's two key objectives as listed.</p> <p>Additional objectives met:</p> <p>Readily identifiable core Enriching environment</p>
B)	<p>CARA Planned Projects</p>	<p>Which project category and activity in the UR Plan does this project fulfill? (See CARA Project Activities document, or Table 2 of the UR Plan and Report.)</p>	<p>Commercial Building Rehabilitation, Transition Area Redevelopment</p>
C)	<p>Development Pattern (Highest and Best Use)</p>	<p>Does it achieve desired land use (e.g., mixed-use, higher density) and/or transportation objectives (e.g., Esplanade, pedestrian-friendly areas)? Is the proposed project desired in this location and the highest and best use of the property?</p>	<p>Zone: Residential Medium Density</p> <p>Under current zoning, a commercial use does not fall within highest and best use options.</p>
D)	<p>Blight</p>	<p>Would it remedy a severely blighted building? How? Does the project utilize a vacant space?</p>	<p>Yes, this would remedy a severely blighted and vacant property.</p>

E)	Preservation	Would it rehabilitate or sensitively redevelop a historic property?	No.
F)	Vitality/People Attractor	Does the general public benefit (i.e. restaurant, carousel, something they can go to; does the project enhance the public's experience of the space; is it a business we are seeking)?	While not a "public attraction" this project will bring business and investment to a currently blighted property.
G)	Retail Hotspot (First Avenue between Lyon and Calapooia)	Is the project located in the Retail Hotspot? If so, will the first floor use be active retail, as recommended in the Retail Refinement Plan?	No.
H)	Sustainable Building	Will the building be built using sustainable practices including LEED or others?	Not addressed in application.
I)	Residential	Is there a residential component? How many units?	No.
<i>Economic Development</i>			
J)	Bring new business to Albany	Will a new business open or come to Albany as a part of this project?	No.
K)	Job Creation	Will the project create additional jobs? How many, what types and what salary level?	1 full time and 1 part time. Salary levels not indicated in application.
L)	Local Labor and Materials	Has applicant specifically called out a commitment to use a certain percent or amount of local labor and/or materials?	Yes, commitment to local labor.
<i>Financial</i>			
M)	Ratio	Proposed public funds Private funds % of CARA Investment	Applicant requesting 70% of total project costs in this phase.
N)	Financial Impacts	What are the financial risks and/or financial benefits to CARA?	Reimbursement based-grant; low financial risk. Benefits through increased value.
O)	Gap	What is the "Gap" or need of the developer?	\$71,107
P)	Private Risk	What is the risk for the developer? What is their skin in the game?	\$29,800 for this phase of the project.
Q)	CARA/City funds	Has the project received other CARA/City funding in the past?	No.
R)	Tax Increment ROI	Is the ROI on this project less than 5 years, less than 7 years?	ROI will be achieved through increased property value.



TO: Albany Revitalization Agency (ARA)

FROM: Sophie Adams, Economic Development Manager

DATE: May 13, 2026, for May 27, 2026, ARA Meeting

SUBJECT: 300 W 1st Avenue Development Discussion

Purpose:

Review status of development pathway for this property and provide guidance on next steps.

Background/Discussion:

The ARA is currently party to an “Option Agreement and Agreement of Purchase and Sale” (“Option”) with Scott Lepman for the property at 300 W 1st Ave. The Option establishes the general terms and development timeline for the project in alignment with the Agency’s stated objectives. Under the agreement, Mr. Lepman pays \$3,500 per month in exchange for the exclusive right to evaluate the project’s feasibility and complete due diligence, design, land use, and permitting activities prior to the Option’s expiration in November 2026.

The Option also requires the parties to execute a development agreement by the end of May 2026. That agreement is intended to further define project details, including the schedule of performance and any applicable penalties. Per prior ARA direction, the project’s required completion date is December 2028.

Since entering into the Option, Mr. Lepman has engaged design and engineering professionals to assist with due diligence efforts and develop multiple design iterations. Throughout the option period, staff and Mr. Lepman have met regularly to discuss development processes, provide design feedback, and negotiate terms of the development agreement. During these discussions, Mr. Lepman has identified several aspects of his proposed design that would create additional costs and introduce uncertainty to the project timeline. As a result, he has indicated that it is not feasible to meet either the May 2026 development agreement milestone or the December 2028 completion deadline.

Following discussion at this meeting, staff requests direction from the Agency regarding next steps for the project. Potential options are outlined below under “Staff Recommendation.”

Strategic Plan Impact:

This project aligns with the Healthy Economy section of the current Strategic Plan, specifically Goal 4: Create a readily identifiable downtown core that is unique and vibrant with a mixture of entertainment, housing, specialty shops, offices, and other commercial uses.

Budget/Staff Impact:

Staffing for this project is provided by the economic development team. Under the current development pathway, there is no direct budget impact in executing this project. Alternative pathways may result in additional one-time costs associated with paving the property.

Staff Recommendation:

Options below align with the goals and objectives of CARA.

1. Continue development relationship with Scott Lepman: extend deadline for Development Agreement Execution date to November 2026 and amend project completion deadline and other necessary provisions following discussion at the meeting. This option continues to pursue highest and best use for the property as defined by the CARA Plan, Albany Development Code, and previous ARA discussion.
2. Terminate the Option to Purchase Agreement with Scott Lepman and develop and execute a recruitment plan for an alternate developer partnership as soon as possible. Pave gravel section of the lot to allow for code-compliant parking in the interim, to be managed by ParkWise.
3. Terminate the Option to Purchase Agreement with Scott Lepman and develop and execute an alternative plan at a future date. Pave gravel section of the lot to allow for code-compliant parking in the interim, to be managed by ParkWise.